

WiMAX Simulation module with management architecture and signaling exchanges

Mohamed Kassab
Institut Telecom / Telecom
Bretagne / RSM departement
Université européenne de
Bretagne, France
mohamed.kassab@telecom-
bretagne.eu

Jean-Marie Bonnin
Institut Telecom / Telecom
Bretagne / RSM departement
Université européenne de
Bretagne, France
jm.bonnin@telecom-
bretagne.eu

Mohamed Mahdi
France Telecom R&D,
Lannion, France
mohamed.mahdi@orange-
ftgroup.com

ABSTRACT

The Worldwide Interoperability for Microwave Access (WiMAX) has drawn tremendous interest from researchers as it is a very promising wireless access technology. Newly developed protocols need to be tested, evaluated and readjusted before becoming operative. In this paper, we present new WiMAX model for SimulX simulator. The originality of this module is the implementation of the management architecture and the signaling exchanges defined by the WiMAX technology. As SimulX is well suited for the simulation of next generation wireless networks, the proposed module will enable the evaluation of WiMAX as a part of these networks. We validate the proposed module based on results of simulation tests, which we compare with theoretical evaluation of the technology.

Keywords

WiMAX simulation, management architecture, signaling exchange, inter-technology handover

1. INTRODUCTION

Nowadays, the trend is toward the use of wireless and mobile networks as required by the multimedia and real-time applications. Many researches are conducted to optimize these promising technologies in order to support communication constraints required by these applications. This is even more difficult in the context of an operator network, which requires the deployment of specific management services such as user authentication and per-user QoS management. Several research fields are explored like the optimization of handover performances in heterogeneous networks or the adaptation of wireless protocols to specific environments, e.g. vehicular network.

Different kinds of tools are available for the evaluation of network architectures and protocols: actual test beds, an-

alytic models and network simulators. The simulation of networks has become a powerful tool used by researchers to perform performance evaluations, especially in wireless networks where actual experimentations are really difficult to set up. This is partially due to the versatile nature of wireless media. Moreover, network simulators provide methods to investigate newly developed protocols, their behaviour and their interactions with other protocols. They allow to validate the feasibility of a design and to remove points of uncertainty. The simulation environments support both, detailed implementations of protocols used for functional validation and implementations limited to basic functionalities of protocols used for scalability evaluations and large scale scenarios.

The *4G Lab of Telecom Bretagne* is a research team interested in the design of protocols and mechanisms necessary for the evolution of wireless networks. Particularly, we have ongoing researches related to the management of mobility in next generation wireless networks based on the integration of several wireless technologies in heterogeneous networks. As part of this work, we needed a simulation environment that allows us to test and evaluate our proposals. Several network simulators are available and commonly used by researchers, such as NS2, OMNET++ and JSim. However, the model of wireless technologies proposed by these simulators present several lacks. As an example, the proposed implementation does not include the management parts of wireless technology specifications such as: core network management entities, signaling state machines and exchanges, etc.

We have been involved in the development of a new network simulator SimulX, which is an open source project developed under the collaboration of several universities and research labs. This simulator is designed to experiment mobility management protocols in an IPv6 world [7]. SimulX provides an open framework for the evaluation of multihoming and mobile protocols. These new protocols are leaving the experimental and research area and attract wireless network providers. To prepare future deployments, the providers are interested in evaluation tools supporting the management aspects of technologies, i.e. management architectures and signaling exchanges. The integration of management services such as user authentication and billing has an impact on the network architecture and handover performances. Therefore, the availability of such tools enables the evaluation of alternate network architectures and management protocols.

Permission to make digital or hard copies of all or part of this work for personal or classroom use is granted without fee provided that copies are not made or distributed for profit or commercial advantage and that copies bear this notice and the full citation on the first page. To copy otherwise, to republish, to post on servers or to redistribute to lists, requires prior specific permission and/or a fee.

NSTOOLS October 19, 2009 - Pisa, Italy.

Copyright 2009 ACM 978-963-9799-70-7/00/0004 ...\$5.00.

SimulX is developed under this perspective. It proposes to integrate management protocols and architectures in addition to data transmission functions to wireless technology models. For example, SimulX implements the Mobile IPv6 protocol [7] and a full signaling support of the IEEE 802.11i authentication protocols and architecture [5]. In addition, SimulX is particularly well suited to facilitate the simulation of handover processes at link layer and network layer of the TCP/IP model. It is quite easy to implement in SimulX new handover procedures and optimizations taken from the literature in order to experiment and compare their performances.

The WiFi was the first wireless technology integrated in the simulator as it is commonly used to offer local wireless access or commercial public wireless access. More recently, the WiMAX technology has been proposed to users and network providers for WMAN broadband access. It is yet seemed to be the future reference for deploying commercial large band wireless access. Therefore, we have been interested in integrating WiMAX to our network simulator. The availability of both WiFi and WiMAX technologies in the simulator will allow the simulation of heterogeneous mobility scenarios. In fact, we are interested by executing simulation scenarios including both WiFi Access Points (AP), WiMAX Base Station (BS) and mobile nodes integrating both WiFi and WiMAX interfaces.

In this work, we present a module for SimulX that implements the WiMAX technology. This module integrates not only the data transmission functions but also the management architecture and the signaling exchanges for authentication, QoS and connectivity management. To validate this module, we propose several simulation scenarios. We compare the obtained results to analytical performance evaluation available in the literature [3, 4]. Then, we propose examples of possible evaluation using this module. An evaluation of the management services effect on the network performances: the network entry delay as a function of the AAA server distance. We also present results of simulation scenario for mobility under a WiFi-WiMAX heterogeneous network. This scenario is presented as examples of the ability of the proposed wireless modules and the simulator to support the design of heterogeneous networks, multi-technology nodes and the execution of inter-technology handovers.

This paper is organized as following. In section 2, we present an overview of the WiMAX technology. In section 3, we detail the integration of the WiMAX technology to SimulX. In section 4, we present simulation scenarios performed using the WiMAX module. We sum up the work presented in this paper and propose our future works in section 4.

2. OVERVIEW OF WIMAX

The WiMAX label was created by the WiMAX Forum [2] to promote last mile wireless broadband networks based on the IEEE 802.16 standard. The specification proposed by IEEE 802.16 standard and its amendments are related to the physical (PHY) layer and wireless medium access (MAC) layer. The WiMAX forum has proposed a complete specification for WiMAX networks, including the management architecture of the core network, beyond what is defined in the version IEEE 802.16e-2005 [1] of the standard. We propose in the following an overview of the MAC and PHY layers, the network architecture and the main services and functions defined by the combine of the WiMAX Forum work [9,

10, 11, 12] and the IEEE 802.16e-2005 specification.

2.1 PHY layer

The IEEE 802.16e-2005 proposes four versions of the physical layer: WirelessMAN-SC, WirelessMAN-SCa, WirelessMAN-OFDM, WirelessMAN-OFDMA. For WirelessMAN-OFDM and WirelessMAN-OFDMA, the PHY supports adaptive modulation and coding. Four modulations are available for physical layer: BPSK, QPSK, 16QAM and 64QAM. These modulations are used with two coding schemas 1/2 and 3/4. Several modulations are defined to allow link adaptation. If the radio link is good, a high-throughput (but with weak immunity against noise and interference) modulation can be used, whereas when the link is bad, a robust modulation (but with low throughput) is used. In conditions of good signal, a highly efficient 64 QAM coding scheme is used, whereas when the signal is poorer, a more robust BPSK coding mechanism is used. In intermediate conditions, 16 QAM and QPSK can also be employed. The WirelessMAN-OFDMA includes support for Multiple-in Multiple-out (MIMO) antennas in order to provide good Non-line-of-sight characteristics (or higher bandwidth) and Hybrid automatic repeat request (HARQ) for good error correction performance.

2.2 MAC layer

The WiMAX MAC layer is designed for point-to-multipoint broadband networks where a base station (BS) transmits to multiple subscriber stations (SS) on its coverage area. The uplink (UL) and the downlink (DL) channel are represented by two separate frames divided into streams of mini-slots. The BS controls the downlink bandwidth by allowing downlink slots to data towards every associated SS. It also controls the uplink bandwidth allocation by allowing transmission slots to SS based on their requests and their service agreements. The BS maintains a time-division multiplexed (TDM) link on the downlink (DL). The subscriber stations use time-division multiple access (TDMA) on the uplink (UL) and transmit back to the BS in their allocated time slots. Two messages, sent in the downlink frame, are used to describe channel use (map) to the SS: DL-MAP for the downlink frame and the UL-MAP for the uplink frame. Figure 1 shows an example of match between UL-MAP and DL-MAP packets and frames.

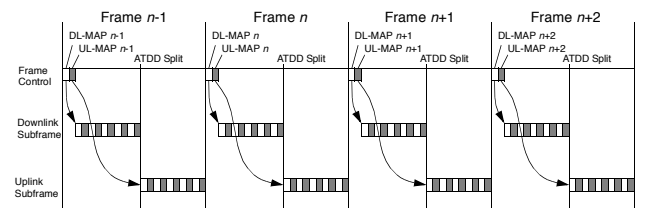

Figure 1: The allocation map for a Time division duplex channel

The MAC layer is connection based. All traffics are carried into connections, even for service flows that implement connectionless protocols. A connection is defined as an unidirectional mapping between a BS and a SS for the purpose of transporting service flow traffics, it is identified by a Connection Identifier (CID). A CID maps a service flow identifier (SFID), which defines the Quality of Service parameters

of the service flow associated with that connection. Security Associations (SAs) also exist to define relation between keying material and CID. At the network entry, management connections in each direction (uplink and downlink) are established between the SS and the BS to exchange management messages. After a successful association, transport connections are created to relay SS traffic.

2.3 General architecture

The WiMAX forum [2] has defined a network reference model that presents functional entities and services for the WiMAX management architecture [9, 10, 11, 12]. The entities composing this model are:

- *The Access Service Network (ASN)*: It contains one or more Base Station(s), and one or more ASN Gateway(s). The BS provides radio access to SSs. The ASN-GW supports Layer-2 (L2) connectivity functions, Relay functions for establishing Layer-3 (L3) connectivity, Mobility management, etc.
- *The Connectivity Service Network (CSN)*: It defines a set of network functions that provides IP connectivity services to subscriber stations such as: mobile terminal IP parameters allocation, Policy and Admission Control, etc. CSN includes network elements such as routers, AAA proxy/servers, user databases, etc.

As shown in Figure 2, an ASN contains multiple Base Stations attached to an ASN-Gateway. The latter is responsible for managing SS mobility between BSs and relay exchanges between ASN entities and CSN. Additionally, BSs may also communicate directly in order to offer fast and seamless handovers.

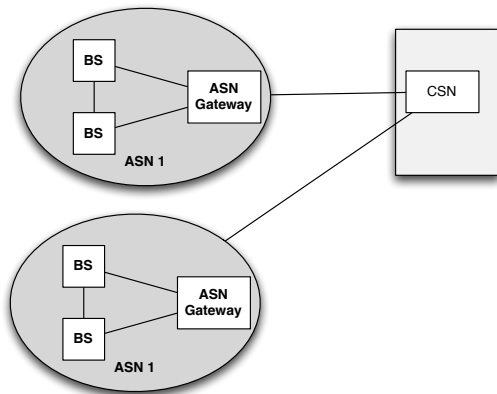

Figure 2: Network Architecture

2.4 Network services and network entry procedure

In this overview, we will focus on the authentication and authorization management, the QoS management and the Data Path management because of their importance for network operations.

Authentication and authorization.

The WiMAX technology defines the Key Management Protocol (PKM) that provides subscriber stations with privacy, authentication and confidentiality across the wireless

network. The PMK is based on mutual authentication procedures that establish shared secrets between entities. Mutual authentication is based on upper layer authentication protocols such as EAP/TLS. The Master Secret Key (MSK) is established between the SS and the AAA server from which an Authorization Key (AK) is derived and transferred to the ASN-GW and the BS. The AK is then used to secure the SA-TEK 3-way-handshake exchange that enables the SS to obtain from the BS the Security Association Identifiers (SAIDs) and properties of Security Associations that includes keying material to secure exchanges through data connections.

QoS management.

The WiMAX technology defines the QoS management over the radio link connections. A station is associated with a number of service flows characterized by QoS parameters such as latency, jitter, throughput, etc. A Service Flow Management (SFM) function, located in the BSs, is responsible for creation, admission, activation and modification of service flows. A Service Flow Authorization (SFA), located in ASN-GWs is responsible for evaluating service request against user QoS profiles. The QoS profile is downloaded from the AAA server, which includes a subscriber management system, to the SFA at the network entry as a part of the authentication and authorization procedure.

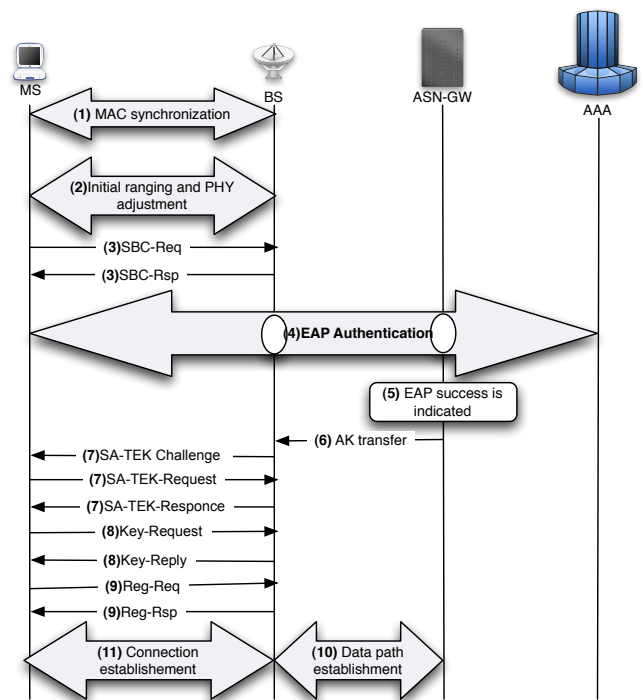

Figure 3: The WiMAX network entry

Data Path management.

The Data Paths (DP) offer the setup of a bearer plane between network peers (BSs and ASN-GWs). They are used to establish tunnels between base stations, between gateways or between gateways and base stations. A Data Path

function is included in every ASN entity and is responsible for instantiating and managing a data bearer. A Data Path between two entities can be specific to a service flow, to a SS (regrouping all SS service flows) or to a BS (regrouping all service flow related to SSs attached to this BS).

2.5 Network entry procedure

The network entry procedure includes a set of phases describing exchanges between the SS and the network entities (BS, ASN-GW and AAA) that enable the attachment of the SS to the network, the negotiation of the network service parameters and the set up connections for pre-provisioned service flows. Figure 3 shows the phases of the WiMAX network entry procedure.

- **Step 1:** The SS scans possible channels of the downlink frequency band until it finds a valid channel. It listens the characteristics of the DL and UL physical channels broadcasted by the BS to determine the channel description parameters.
- **Step 2:** The initial ranging is the process permitting to the SS to acquire timing offsets, power transmission adjustments and identifiers of management connections to be used in the next phases of the procedure.
- **Step 3:** During the basic capabilities negotiation, the SS and BS, among other parameters, negotiate the additional physical parameters, PKM protocol version, Authentication Policy, etc.
- **Step 4:** The SS and the AAA execute mutual authentication procedure. The related exchanges are relayed by the BS and the ASN-GW.
- **Step 5:** The ASN-GW receives indication about the success of the authentication and the SS authorization profile including the MSK and its lifetime.
- **Step 6:** The ASN-GW indicates to the BS the completion of the authentication process and transfers to it the AK context.
- **Step 7:** The 3-way handshake is conducted between BS and SS to verify the AK.
- **Step 8:** The SS acquires the valid TEK keys using Key-Request/ Reply exchange for each Security Association (This step is repeated for each service flow).
- **Step 9:** The registration procedure carries the SS supported capabilities such as mobility parameters and handover support.
- **Steps 10 & 11:** The ASN-GW triggers the creation the pre-provisioned service flows and related data paths.

3. WIMAX SIMULATION MODULE

In this section we present the design of the WiMAX module we have integrated to SimulX. As indicated in section 1, SimulX is a network simulator supporting features that enable the design and the evaluation of future communication protocols like cross layer interactions, multi-interface inter-working in terminals, heterogeneous network environments. This simulator offers a C++ simulation class library where protocols are modules derived from a mother class

Handler. This allows to protocols to be plugged together in an arbitrary manner. Therefore, a very fine granularity of simulation complexity is possible. For example, if a protocol is not in a device for a certain simulation, it can be omitted from the protocol stack [7].

A WiMAX module have been already proposed for the NS2 simulator. This module proposes a partial implementation of the WiMAX technology [8]. It includes PHY and MAC layers with elements modeling the wireless medium, the MAC downlink and uplink channel and MAC functions for channel access. However, it does not implement all the IEEE 802.16e-2005 specification and does not include elements defined by the WiMAX forum work [9, 10, 11, 12] related to the management architecture and MAC layer features such as user authentication, data path management, etc.

The design of PHY and MAC layers proposed by the NS2 WiMAX module is interesting as it corresponds to the standard specification apart the network entry signaling and MAC services. We reuse the design proposed by the NS2 WiMAX module for the PHY and MAC layers. Our design efforts focus on the improvement of this design by completing the function of the MAC layer, the network entry procedure and the integration of the core network functions defined by the WiMAX forum. We propose an overview of the WiMAX module integrated in NS-2 and then we present the features of the WiMAX module that we integrated in SimulX.

3.1 NS2 WiMAX module

3.1.1 PHY layer

The NS2 WiMAX module implements the WirelessMAN-OFDM version of the physical layer over the *OFDM C++* class. The latter supports adaptive modulation and coding as specified by the standard. The implementation of the PHY layer allows to fix a specific modulation for a terminal according to the distance and the interferences. The *OFDM* class defines methods used by the MAC layer during data transmission such as *getTrxTime* that indicates transmission time of a packet.

3.1.2 MAC layer

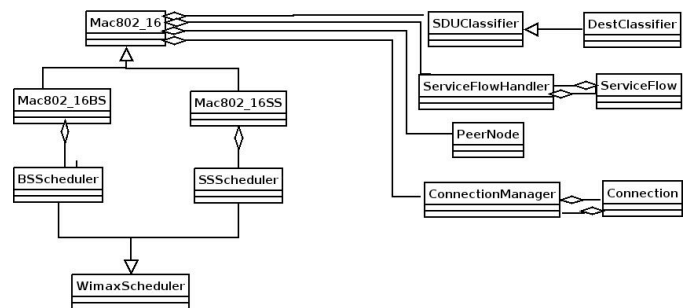

Figure 4: C++ classes for the MAC layer functions

The MAC layer proposed by the NS2 module includes the main functions required for the data exchanges between a BS and SSs. The two sets of C++ classes are defines. The first set models the protocol layer as it is integrated in the network entities, i.e. SS and BS. Figure 4 shows the C++ classes modeling the MAC layer. The abstract class

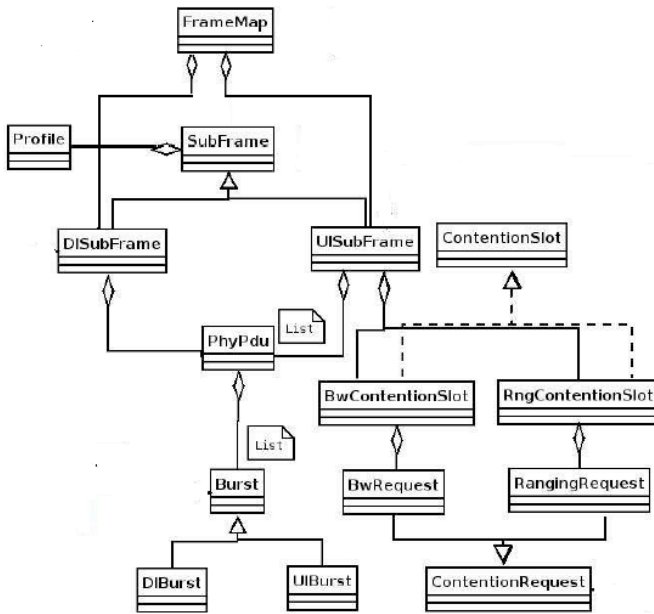

Figure 5: C++ classes for the uplink and downlink frames

Mac802_16 defines MAC functions common to the MAC layer of BS and SS such as the message classifier modeled by the *SDUClassifier* class. Two classes, *MAC802_16SS* and *MAC802_16BS*, are derived for the BS and the SS. They include specific functions for each entities such as the schedulers: *BSScheduler* and *SSScheduler*. The second set of classes embodies the wireless channel. The class *FrameMap* models the frame structure defines by the IEEE 802.16. It includes instances of *USubFrame* and *DSubFrame* classes that model respectively the uplink subframe and the downlink sub-frame. Figure 5 shows the C++ classes modeling the wireless channel.

3.2 SimuX WiMAX module

3.2.1 Management Architecture

To model the management architecture, we propose a set of classes that implement the entities defined by the ASN and CSN [6]. This implies the definition of new protocols that enables the design of BSs supporting the WiMAX forum management functions and new network entities: the ASN gateway and the authentication server. Figure 6 shows the proposed design for network entities.

Base station.

For the new design of BS, we define two new protocol layers *BS_Bridge* and *WiMAX_Mgmt_BS*. The former is a class that enables to interconnect the IEEE 802.16 MAC layer of a BS with another link layer by acting as a bridge. The *WiMAX_Mgmt_BS* implements the functions assigned to the BS to manage the Data path establishment, the user authentication, the exchange with ASN-GW and neighbor BSs.

ASN Gateway.

For the design of ASN gateway, we define two new classes:

the *WiMAX_Mgmt_GW* and *GW_Bridge*. The first class implements the function of the ASN-GW such as the data path management and the user mobility. The *GW_Bridge* class is a link layer bridge that interconnects several ASN network over wired interfaces.

Authentication server.

For CSN part of the network, we consider the authentication function based on EAP/TLS and a RADIUS server. Protocols needed for the design of the authentication server, i.e. RADIUS, EAPoL, EAP and TLS, are already available in SimuX. They have been added in a previous work related to the support of user authentication in WiFi networks [5].

The core network entities are interconnect using a *Router-Box* entity. The latter is a C++ class that models a wired core network. It defines a matrix that represents transmission delays between entities connected to the box.

3.2.2 MAC functions and network entry procedure

Regarding the modeling of data exchanges, we have exported some of NS2 WiMAX module that we accommodate to the SimuX design. We complete the *MAC802_16SS* and *MAC802_16BS* classes by including missed phases in the network entry state machine: negotiation capability, user authentication, key derivation and data path negotiation. We also define the management messages and functions required to model the related exchanges. As result, we propose an implementation of authentication, data path, and mobility management services as they are defined by the WiMAX forum specification.

4. SIMULATION RESULTS

We propose the results of simulation scenarios that validate the implementation of the PHY layer and data transmission functions. Furthermore, we make use of our WiMAX module to evaluate the effect of management services on the network performances. We also present results of simulation scenarios using our WiMAX module to evaluate heterogeneous network performances.

4.1 Data transmission performances

4.1.1 Scenario with a single service flow

We perform a simulation scenario to check if each physical mode, a modulation with the right coding schemas (c.f.2.1), results to the correct MAC throughput. In this scenario, we model one BS offering WiMAX access to two SSs. A constant traffic is sent by one SS to the second based on the WiMAX connection. We measure the DL and UP MAC throughputs. We assume, in this scenario, that the transmission at the physical level is without error.

Figures 7 and 8 illustrate the relationship between carried and offered traffic in the MAC layer. This relation is linear and as long as the offered traffic does not exceed the maximum possible bit rate of the corresponding modulation, it is fully carried. When the latter reaches and exceeds the saturation level the MAC throughput remains constant. We also note that the throughput in the uplink is still higher than the downlink direction. This result is expected, since the BS periodically sends management messages (DLMap, ULMap, DCD,UCD) in the downlink direction. [3] has proposed a study that evaluates the performances of WiMAX PHY

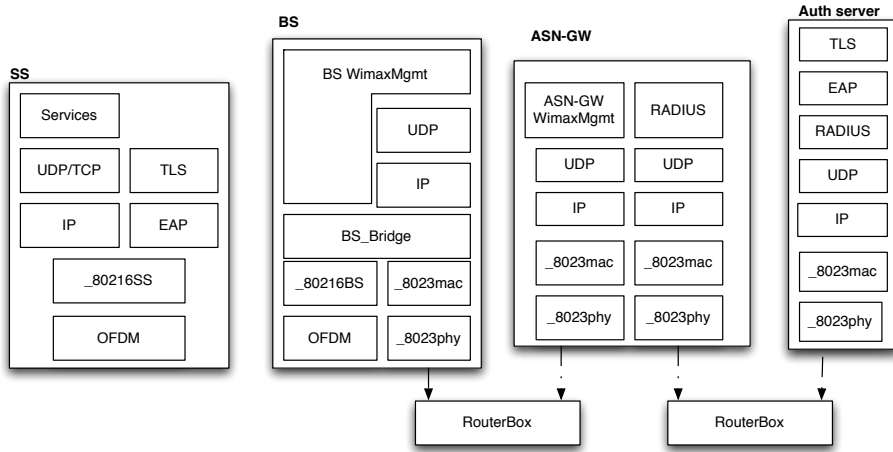

Figure 6: Network entities' design

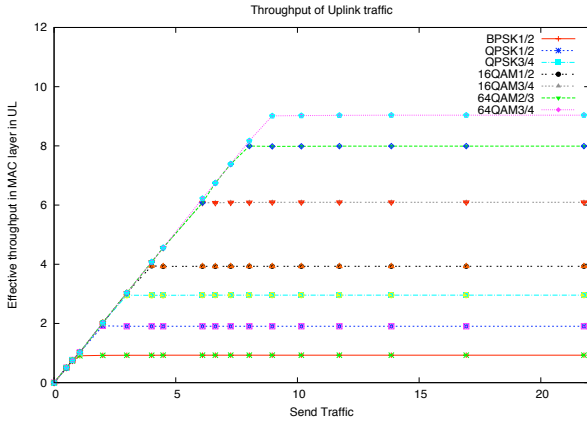

Figure 7: UL data rate

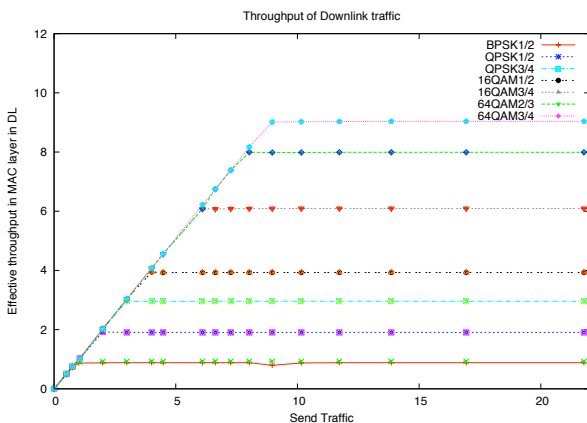

Figure 8: DL data rate

Table 1: The MAC maximum throughput for different modulations

Modulation	Coding	Maximum throughput	
		simulated	theoretical
<i>BPSK</i>	1/2	1.8	1.89
<i>QPSK</i>	1/2	3.76	3.95
	3/4	5.89	6
<i>16QAM</i>	1/2	7.82	8.06
	3/4	12.01	12.18
<i>64QAM</i>	1/2	15.95	16.30
	3/4	18.05	18.63

Table 2: Parameters of multi-user scenario

Modulation	Coding	Number of SS
<i>BPSK</i>	1/2	6
<i>QPSK</i>	1/2	3
	3/4	4
<i>16QAM</i>	1/2	1
	3/4	1

layer based on an analytic model. We compare the maximum throughputs obtained during the simulation with those found in [3]. Table 1 lists maximum throughputs, for each modulation types, obtained by the simulation and the theoretical study. We show that results showed by the simulator are quite close to the theoretical ones. The difference is due to the simplifications necessary to adapt the specification of the PHY layer to the simulator design.

4.1.2 Scenario with multiple users

The scenario defines fifteen SSs with different physical mode communicating with core network over one BS. Table 2 details the modulations and coding schemas used. SSs send packets with a size of 381 bytes and the frame duration is 10 ms. The bandwidth is shared equally between the fifteen stations and the physical link is free error. The number of SSs and used PHY modes have been computed analytically in [4] so that all SSs are served in the same frame. Figure 9 shows the downlink throughput as a function of the

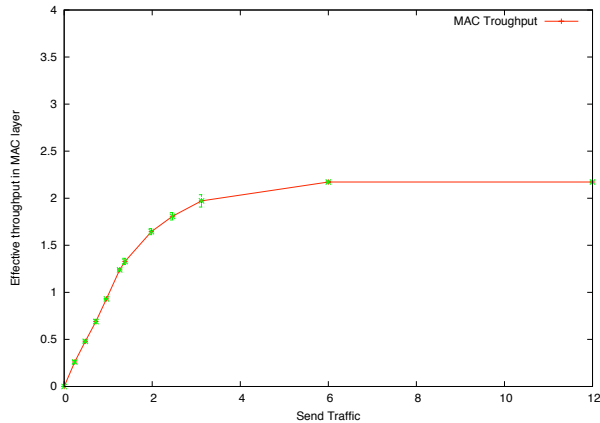

Figure 9: MAC data rate with multi-users scenario

offered traffic. There is a threshold saturation network 1.69 Mbyte/s. The analytical study has shown a saturation at 1.54 Mb/s [4]. This is due to two causes. In the analytical model [4], the modulation of the physical link considers the possibility of error which is not the case with the simulation PHY link. Moreover, in [4] the analytical model does not implement the fragmentation/reassembly of messages while in the SimulX module, we consider this MAC function, which improve the MAC capacity results.

4.2 Network entry delay evaluation

The main contribution of our WiMAX module is the implementation of the signaling and the architecture for management part of the WiMAX technology. In our ongoing researches we are interested in the evaluation of the influences of management functions on mobility performances. We propose to evaluate the network entry delay (which may influence the handover delay) as a function of some network configuration parameters. We consider the frame duration and the distance of the authentication server.

4.2.1 Frame duration

The frame duration, which is a configurable parameter in WiMAX, has a significant influence on the throughput offered to SSs. When the frame duration increases, the number of served SSs and the amount of traffic sent in downlink increases. This parameter has also an influence on the network entry delay of new SSs. In this scenario, we consider a network with one BS offering access to a single SS. The transmission delays between the ASN-GW and BS and between the ASN-GW and AAA are fixed to 5 ms. We measure the network access delay with different frame duration. The results are plotted in Figure 10. As expected, this delay increases as the frame duration increases. A frame duration of 5 ms allows to reduce 200 ms of the network access delay. However, this penalizes the throughput offered to SSs by increasing the signaling traffic.

4.2.2 Distance of AAA server

A parameter that may influence the network access delay is the architecture of the network. Particularly, the trans-

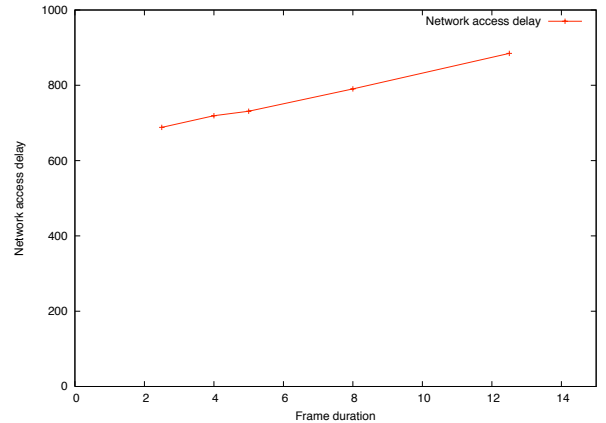

Figure 10: Network access delay vs. Frame duration

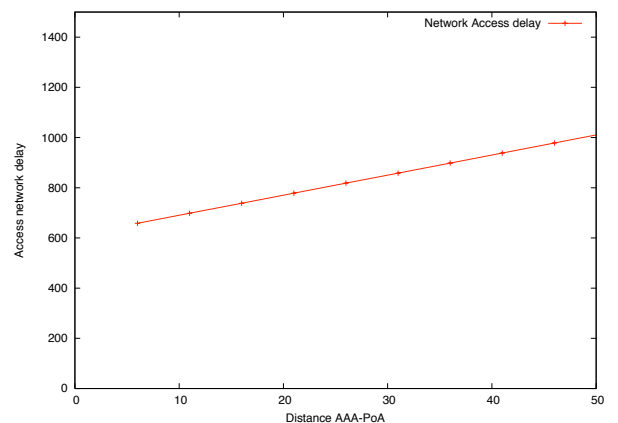

Figure 11: Network access delay vs. distance BS-AAA

mission delays between the network entities implied in the network entry procedure, i.e. BSs, ASN-GW and the authentication server, have an effect on the network access delays. We propose a simulation scenario that measures the network access delay with different transmission delay between BSs and AAA. We consider a frame duration of 10 ms. Figure 11 shows the results. The network access delay is upper then 600 ms when the distance between the BS and the AAA is 5 ms i.e. when the BS and the AAA are in the same network. This delay can reach 1 second when the distance between the BSs and the authentication server is upper than 50 ms, which is an assumption more reasonable in operational deployments.

4.3 Inter-technology handover

As indicated in previous sections, the architecture of SimulX makes possible to perform simulation scenarios based on wireless networks integrating heterogeneous technologies and

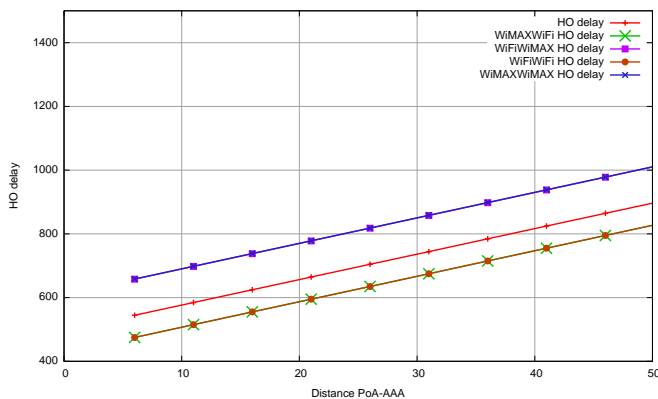

Figure 12: HO delay vs. distance PoA-AAA

multi-technology nodes. As an example, we propose a simulation scenario integrating WiFi APs and WiMAX BSs in the same network offering wireless access to mobile nodes with WiFi and WiMAX interfaces. We evaluate the handover delay performed by a mobile node moving over the wireless coverage. In this scenario, we deploy six BSs bound to the same ASN-GW. Under the coverage of each BS we deploy six APs. All the point of attachments (APs and BSs) are considered in the same sub-network so that an inter-technology handover fit to a layer-2 handover. The AAA is connected to another sub-network. The ASN-GW is connected to the two sub-networks. The mobile node is moving at a constant speed of 1m/s following a straight path so that it crosses all WiMAX cells. In each WiMAX cells, it crosses at least four WiFi cells. Thus, the mobile node execute a set of inter and intra technology handovers. Figure 12 shows the average of the handover delay for each type of handover (WiFi to WiMAX, WiMAX to WiFi, WiFi to WiFi and WiMAX to WiMAX) as a function of the transmission delay between the PoAs' sub-network and the AAA server. The figure shows that handover delays are quite large for intra and inter technology handover : upper then 475 ms when handover are executed with APs and upper then 600 ms when the handover are executed with BSs. It is clear that even in the case of an inter-technology mobility that does not lead to a layer-3 handover, the handover delays are over real time application requirements. To reduce these delays, there is a need to define mechanisms that optimize the layer-2 handover for intra-technology and inter-technology mobility. This is the subject of our ongoing work.

5. CONCLUSION

Network simulators provide the opportunity to investigate newly developed protocols studying their behavior and their interactions with other protocols. They allow to validate the feasibility of a design and to remove points of uncertainty. SimulX is a network simulator that provides an open framework for the evaluation of protocols for wireless networks. It is quite easy to implement in SimulX new protocols and optimizations taken from the literature in order to experiment and compare their performances. The main goal of this simulator is the support of heterogeneous networks and multi-technology nodes simulation, the integration of management architectures of wireless technologies and the simulation of

handover processes at the link layer and the network layer. In this work, we present a module for SimulX that implements the WiMAX technology. This module integrates, in addition to the data transmission functions, the management architecture and the signaling exchanges for authentication, QoS and connectivity management defined by the WiMAX forum. In a first part, we present how we fit the architecture and protocols proposed by the WiMAX specification to the simulator design. In a second part, we propose two scenarios that evaluate the implementation of the PHY layer and data transmission functions. Their outcomes have been compared with theoretical results available in the literature [3, 4]. This validates the correctness of our implementation.

Then, we present results of a simulation scenario that uses our WiMAX module to evaluate the effect of management services on the network performances. We propose an evaluation of the network entry/re-entry delay as a function of the WiMAX frame duration and the distance between BSs and the AAA server. We show that values of these parameters have to be fixed carefully as they have a significant effect on the network entry delay.

Finally, we present results of simulation scenario for mobility under a WiFi-WiMAX heterogeneous network. The measured handover delays are over real time application requirements, which point out the need to define mechanisms that optimize the layer-2 handover for intra-technology and inter-technology mobility.

In our future work, we will focus on the simulation of optimization mechanisms for inter-technology handovers, we are defining, using SimulX. These simulations will take advantage of the support of multi-technology simulations and the integration of management architecture protocols of several wireless technologies.

6. REFERENCES

- [1] I. L. S. Committee. Part 16: Air interface for fixed and mobile broadband wireless access systems, amendment 2: Physical and medium access control layers for combined fixed and mobile operation in licensed bands. Standard, IEEE Computer Society, February 2006.
- [2] W. Forum. Wimax forum web page, september 2008.
- [3] A. Ghosh, D. R. Wolter, J. G. Andrews, and R. Chen. Broadband Wireless Access with WiMAX 802.16: Current Performance Benchmarks and Future Potential. *IEEE Communications Magazine*, 43(2):129–136, February 2005.
- [4] C. Hoymann. Analysis and performance evaluation of the OFDM based metropolitan area network IEEE 802.16. *Computer Networks*, 49(3):341–363, October 2005.
- [5] M. Kassab, S. Hachana, J. Bonnin, and A. Belghith. High-mobility effects on wlan fast re-authentication efficiency. *FTDA-DN workshop, Held in conjunction with Qshine 2008*, July 2008.
- [6] M. Mahdi. Gestion de mobilité inter-technologie WiFi-WiMAX : Evaluation par simulation . Technical report, ENSI & Telecom Bretagne, March 2008.
- [7] N. Montavont, J. Montavont, and S. Hachana. Wireless IPv6 simulator: SimulX. *40th Annual Simulation Symposium, Norfolk, VA, Part of the 2007 Spring Simulation Multiconference*, March 2007.

- [8] R. Rouil. Seamless and secure mobility (<http://www.antd.nist.gov/seamlessandsecure.shtml>), 2007.
- [9] N. WG. Wimax forum network architecture stage 2: Architecture tenets, reference model and reference points, part 0. Wimax end-to-end network systems architecture, WiMAX Forum, August 2007.
- [10] N. WG. Wimax forum network architecture stage 2: Architecture tenets, reference model and reference points, part 1. Wimax end-to-end network systems architecture, WiMAX Forum, August 2007.
- [11] N. WG. Wimax forum network architecture stage 2: Architecture tenets, reference model and reference points, part 2. Wimax end-to-end network systems architecture, WiMAX Forum, August 2007.
- [12] N. WG. Wimax forum network architecture stage 3: Detailed protocols and procedures. Wimax end-to-end network systems architecture, WiMAX Forum, March 2007.