

CCCDBA Based Implementation of Sixth Order Band pass Filter

Ramola Vishal¹, Mishra Saurabh², Singh R.K.³, Chauhan D.S⁴

¹ Assistant Professor, Department of Electronics and Communication Engineering, Shivalik College of Engineering, Dehradun, Uttarakhand, India, vishal_anu@hotmail.com

² Assistant Professor, Department of Electronics and Communication Engineering, Graphic Era University, Dehradun, Uttarakhand, India, saurabhmishra2004@gmail.com

³ Professor, Department of Electronics and Communication Engineering, Kumaon Engineering College, Dwarahat, Almora, Uttarakhand, India

⁴ Vice chancellor, Uttarakhand Technical University, Dehradun, Uttarakhand, India

Abstract - In the present paper implementation of sixth order band pass filters have been proposed by using current-controlled current differencing buffered amplifier (CCCDBA). In the present work, an effort has been made to simulate the sixth order doubly-terminated LC ladder band pass filter, using CCCDBA. Here, in each circuit more than one CCCDBA and few grounded capacitor without have been utilized. The designed circuits are very suitable for integrated circuit and very easy in implementation. The circuits' performance is simulated through PSPICE and its simulated results obtained so is comparable to the theoretical one.

Key Words - Current-controlled current differencing buffered amplifier (CCCDBA), Doubly Terminated LC Ladder Filter, Sixth order band pass filter, current-controlled current differencing buffered amplifier (CCCDBA), Leapfrog Band pass Filter, Resonant Section Using CCCDBA.

1 Introduction

A basic approach for building higher-order filters is to emulate a passive LC ladder filter which possesses low sensitivities in the pass band. The basic approach of this paper is to realize a band pass filter by low pass to band pass transformation. Electronically tunable current mode ladder filters using current controlled CDDBA has been presented in this paper. In this paper we have presented the design and simulation of sixth order doubly-terminated LC ladder band pass filter.

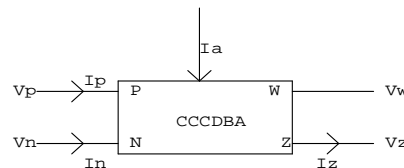

Fig. 1: Symbolic representation of current-controlled CDDBA [7],[8]

A current differencing buffered amplifier (CDBA), which is a new active circuit building block especially suitable for the realization of a class of continuous-time filters, has been introduced, whose bipolar-based realization is introduced and used for the realization of active and passive filters. It offers several advantageous features such as:-

- a) high-slew rate,
- b) freedom from parasitic capacitances,
- c) wide bandwidth and,
- d) Simple implementation.

Since the proposed circuits are based on CCCDBAs, a brief review of CCCDBA is given here. CCCDBA is a translinear based current-controlled current differencing buffered amplifier (CC-CDBA's) whose parasitic input resistances can be varied electronically. Basically, the CCDBA is a four-terminal active element. For ideal operation, it's current and voltage relations described by the equation-1. [11],[12],[13].

From the circuit operation, the current-voltage characteristics of CC-CDBA can be expressed by the following matrix.

$$\begin{bmatrix} v_p \\ v_n \\ i_z \\ v_w \end{bmatrix} = \begin{bmatrix} 0 & 0 & R_x & 0 \\ 0 & 0 & 0 & R_x \\ 0 & 0 & 1 & -1 \\ 1 & 0 & 0 & 0 \end{bmatrix} \begin{bmatrix} v_z \\ i_z \\ i_p \\ i_n \end{bmatrix} \tag{1}$$

2 Operation

2.1 Sixth Order Doubly Terminated Lc Ladder Band Pass Filter

The circuit of a doubly-terminated LC ladder band pass filter is obtained by applying frequency transformation to the doubly terminated LC ladder low pass section as given by Figure-2

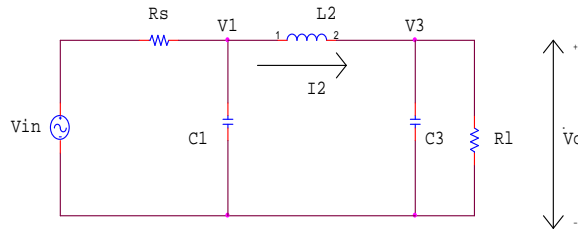

Fig.2: Doubly Terminated LC Ladder Filter (Low pass Section)

A low pass characteristic can be transformed to a band pass characteristic by the low pass to band pass transformation given by:

$$p = \frac{s^2 + \omega_0^2}{\omega_{3dB}s} = \frac{Q(s_n^2 + 1)}{s_n} \quad (2)$$

Where, $Q = \frac{\omega_o}{\omega_{3dB}} = \text{QualityFactor}$ (3)

And

$$s_n = \frac{s}{\omega_o} \text{ And } \omega_o = \text{Center frequency} \quad (4)$$

Also, $\omega_o = (\omega_l\omega_u)^{1/2} \approx \omega_l + \omega_u/2$ for, $\frac{\omega_o}{\omega_{3dB}} \gg 1$. (5)

$$\omega_{3dB} = \omega_u - \omega_l. \quad (6)$$

From, the above equation it is clear that the series inductor element should be replaced by a series combination of inductor and capacitor whereas the shunt capacitor element is replaced by a parallel combination of inductor and capacitor. So the resultant network thus obtained after applying the required frequency transformation is shown in Figure-3.

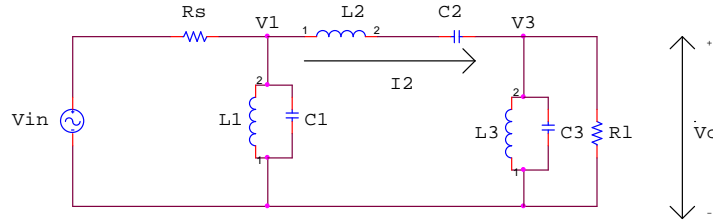

Fig.3: Doubly Terminated LC Ladder Filter (Band pass Section)

To obtain the circuit realization of the filter in the form of voltage-adder and voltage-integrators mathematical calculations are carried out and we arrive at the following results:

$$V_1 = \frac{s \left(\frac{1}{C_1 R} \right)}{s^2 + s \left(\frac{1}{C_1 R} \right) + \left(\frac{1}{L_1 C_1} \right)} \left(V_{in} - \hat{V}_2 \right) \quad (7)$$

$$\hat{V}_2 = \frac{s \left(\frac{R}{L_2} \right)}{s^2 + s \left(\frac{1}{L_2 C_2} \right)} \left(V_1 - V_3 \right) \quad (8)$$

$$V_1 = \frac{s \left(\frac{1}{C_3 R} \right)}{s^2 + s \left(\frac{1}{C_3 R} \right) + \left(\frac{1}{L_3 C_3} \right)} V_2 \tag{9}$$

$$V_o = V_3 \tag{10}$$

From equation-8 it is observed that we require a second order resonant section which can be implemented by cascading two lossless integrators as shown by the block diagram representation in Figure-4 and the corresponding circuit realization of the resonant section as depicted by Figure-5.

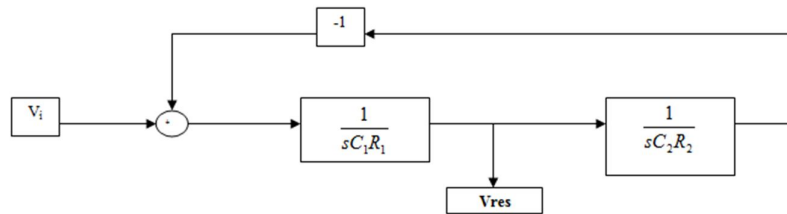

Fig.4: Block Diagram of Resonant Section

The transfer function of the resonant section shown in Figure-3 is thus calculated to be as follows:

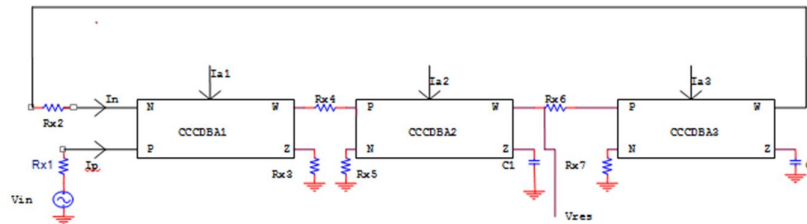

Fig.5: Circuit Realization of Resonant Section Using CCCDBA

With the help of the above four equations from equation 7 to equation 9, we can obtain the block-diagram of Figure-3 which is depicted in Figure-6 and the circuit realization is shown in Figure-7

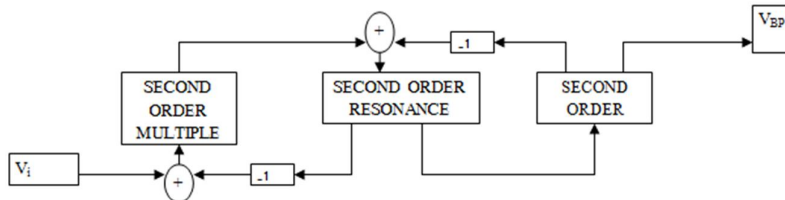

Fig.6: Block Diagram of Sixth Order Leapfrog Filter (Bandpass Section)

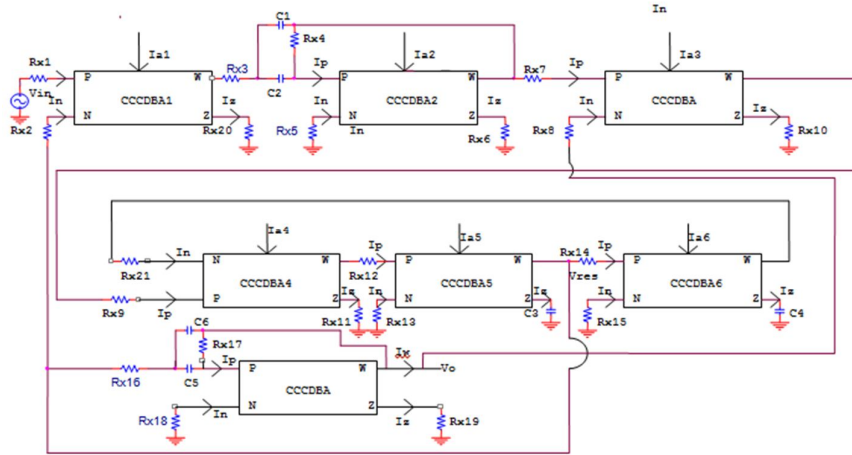

Fig.7: Circuit Diagram of Sixth Order Doubly Terminated LC Ladder Leapfrog Band pass Filter Using CCCDBA

The transfer function of the circuit shown in Figure-7 is given by the following equation:

$$\frac{V_o(s)}{V_{in}(s)} = \frac{\left(\frac{1}{8}\right) s^3 \left(\frac{8}{C^3 R^3}\right)}{s^6 + 4s^5 \left(\frac{1}{CR}\right) + 5s^4 \left(\frac{1}{C^2 R^2}\right) + s^3 \left(\frac{8}{C^3 R^3}\right) + s^2 \left(\frac{7}{C^4 R^4}\right) + s \left(\frac{4}{C^5 R^5}\right) + \left(\frac{1}{C^6 R^6}\right)} \quad (12)$$

In deriving the above transfer function we have taken following the conditions: $R_{x4} = R_{x12} = R_{x14} = R_{x16} = R_{x17} = R$, $R_{x3} = R/4$. Also, $C_3 = C_4 = C$, $C_2 = C_5 = C/4$ and $C_1 = C_6 = 4C$.

The expression for cut-off frequency is calculated as follows:

$$f_o = \frac{(4)^{1/6}}{2\pi CR} \quad (13)$$

3 Simulation Results

Figure-8 depicts the SPICE simulation results of the second order resonant section while figure-8 depicts the SPICE simulation results of the proposed sixth order LC ladder band pass filter circuit which gives the value of center frequency to be 45.186 KHz and bandwidth to be 26.677 KHz.

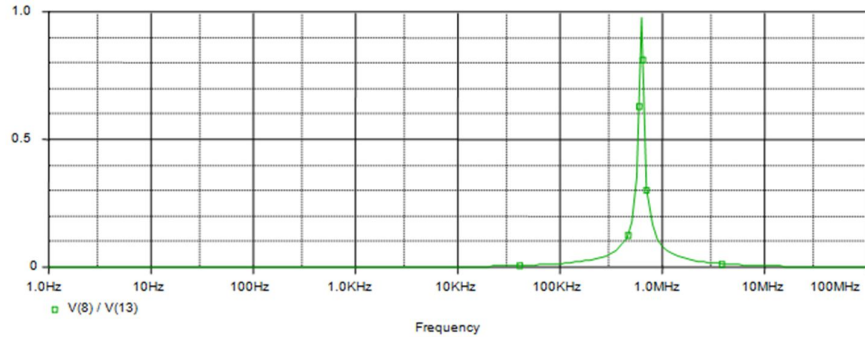

Fig.8: Response of Second Order Resonance Section

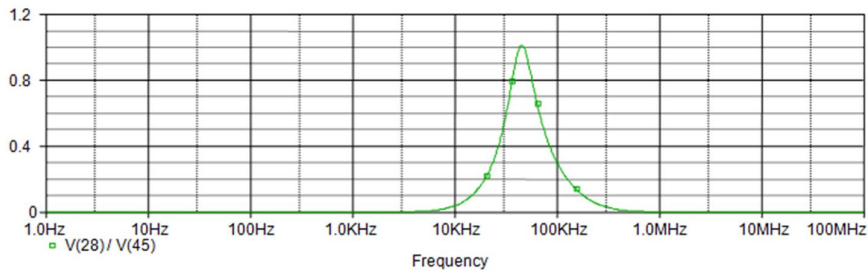

Fig.9: Response of Sixth Order LC Ladder Band Pass Filter

4 Conclusion

We observe that the realized filter works in accordance with the theoretical values for Butterworth response with $R = 520\Omega$ and the value of the capacitor to be $C = 4nF$ gives the value of the center frequency to be approximately equal to 96.405 KHz. At the time of realizing band pass filter we come across a second order resonant section, which was implemented by cascading two lossless integrators. Also, in realizing sixth order band pass filter we require two second order band pass sections which are implemented using multiple feedback band pass filters.

References

- Tangsrirat, W. and Surakamponorn, W.,(1993), "Realization of multiple-output biquadratic filters using current differencing buffered amplifier," *International Journal of Electronics*, vol.92,No.6,pp.313-325.
- 1.Akerberg D. and Mossberg K., "A Versatile Building Block: Current Differencing Buffered Amplifier Suitable for Analog Signal Processing Filters", *IEEE Trans.Circuit Syst.CAS-21*, , pp.75-78,(1974).

2. Frey D. R., "Log-domain filtering: an approach to current-mode Filtering", *IEEE Proceedings*, Pt. G., Vol.140, pp. 406-416, (1993).
3. Jaikala, W. Sooksood. K., and Montree. S., "Current-Controlled CDBA's (CCCDBA's) based Novel current-mode universal biquadratic filter", *IEEE Trans., ISCAS 2006*, pp. 3806-3809, (2006).
4. Keskin, A.U. and Hancioglu, E., "CDBA-based synthetic floating inductance circuits with electronic tuning properties", *ETRI Journal*, Vol.27, No.2, pp. 239-242,(2005).
5. Maheshwari S. and Khan I.A. , "Current controlled current differencing buffered amplifier: implementation and applications," *Active and Passive Electronics Components*, Vol.27, No.4, pp.219-222(2004),.
6. Maheshwari S., "Voltage-Mode All-Pass filters including minimum component count circuits", *Active and Passive Electronic Components*, vol. 2007, pp. 1-5(2007).
7. Sumaytee Pisitchalempong, Danucha Prasertsom, Thanawat Piyatat, Worapong Tangsriat and Wanlop Surakampontrorn, " current tunable quadrature oscillator using only CCCDBAs and grounded capacitor" , *ECTI-con 2007 The 2007 ECTI international conference*, pp.32-35, (2007)
8. Tangsriat, W. Surakampontrorn W. and Fujii, N., "Realization of Leapfrog Filters Using Current Differential Buffered Amplifiers", *IEICE Trans. Fundamental.*, vol. E86-A, No.2, pp. 318-326, (2002).
9. Tangsriat W and Surakampontrorn W., "Electronically tunable floating inductance simulation based on Current-Controlled Current Differencing Buffered Amplifiers", *Thammasat Int. J. Sc. Tech.*, vol. 11, no. 1, pp. 60-65, (2006).
10. Tangsriat W. and Surakampontrorn W, "Realization of multiple-output biquadratic filters using current differencing buffered amplifier," *International Journal of Electronics*, vol.92,No.6,pp.313-325, (1993).
11. Toker A., Ozouguz S., and Acar C., "Current-mode KHN- equivalent biquad using CDBAs", *Electronics Letters.*, Vol. 35, No. 20, pp. 1682-1683, (1999).
12. Worapong Tangsriat, " Novel minimum-component universal filter and quadrature oscillator with electronic tuning property based on CCCDBAs" , *Indian Journal of pure and applied physics*, Vol. 47, pp. 815-822, (Nov 2009).
13. Worapong Tangsriat and Wanlop Surakampontrorn, " Electronically tunable quadrature oscillator using current controlled current differencing buffered amplifiers" , *Journal of active and passive electronic devices*, Vol.4, pp. 163-174, (2009).