

# Performance Analysis of the IEEE 802.1 Ethernet Audio/Video Bridging Standard

Hyung-Taek Lim,  
Daniel Herrscher  
BMW Group Research and  
Technology  
Munich, Germany  
{Name.Lastname}@bmw.de

Martin Johannes Waltl  
Technische Universität  
München  
Munich, Germany  
martin.waltl@mytum.de

Firas Chaari  
Telemotive AG  
Munich, Germany  
firas.chaari@telemotive.de

## ABSTRACT

Switched Ethernet is widely used for all kinds of applications. However, for demanding multimedia streaming applications in a fully-loaded network, legacy Ethernet is not the best choice due to its limited Quality-of-Service (QoS) support. The new specification of the IEEE 802.1 Audio/Video Bridging (AVB) standard, an extension to legacy Ethernet, provides the QoS features needed for multimedia streaming: Time synchronized low latency streaming services and bandwidth reservation on Layer-2. In this work, we study and analyze the AVB standard based on a simulation approach to verify the specified constraints and to determine the feasibility of the mechanisms in a switched Ethernet network. We use the simulation tool OMNeT++ and extend the existing INET-framework to support all the required protocols specified in the IEEE 802.1 AVB standard.

## Categories and Subject Descriptors

C.2.1 [Computer-Communication Networks]: Network communications; C.4 [Computer Systems Organization]: Performance Evaluation

## Keywords

Quality-of-Service (QoS), Real-Time Communication, IEEE 802.1 Ethernet Audio/Video Bridging (AVB)

## 1. INTRODUCTION

The switched Ethernet became the most widely used local area networking (LAN) technology in the last years and decades due to the easy installation process, different data rate support and the low cost chipsets. In the beginning, Ethernet was used in home and office environment based on a CSMA/CD mechanism with coaxial cables and 10Mbit/s links in a network (10Base-2, 10Base-5). All devices are connected with hubs, where the shared medium is used and

Permission to make digital or hard copies of all or part of this work for personal or classroom use is granted without fee provided that copies are not made or distributed for profit or commercial advantage and that copies bear this notice and the full citation on the first page. To copy otherwise, to republish, to post on servers or to redistribute to lists, requires prior specific permission and/or a fee.  
Simutools 2012, March 19-23, Desenzano del Garda, Italy  
Copyright © 2012 ICST 978-1-936968-47-3  
DOI 10.4108/icst.simutools.2012.247747

frame collisions are occurring. This disadvantage was improved by introducing switches and twisted pair cables in a network based on a 10/100Base-TX standard so that a point-to-point communication is realized and frame collisions are not occurring. However, there are some limitations regarding to the Quality-of-Service (QoS) support in a switched Ethernet based network. The network should be able to meet the constraints of different applications so that a switched Ethernet is used in other fields such as in the industrial, aeronautic and in-vehicle network. In case of an in-car network, prioritization mechanisms as specified in the IEEE 802.1Q standard should be used to guarantee the performances of the highest traffic class in an Ethernet based in-vehicle network [17]. In addition, other mechanisms have to be used to guarantee the constraints of other real-time applications such as real-time streaming data.

The Audio/Video Bridging (AVB) task group [11] added several IEEE standards to achieve the QoS requirements for low latency streaming in Ethernet networks which are summarized in the IEEE 802.1 AVB standard. All of the mechanisms are ratified and finally published in 2011, but the standard in combination with all the specified protocols is not evaluated yet. For this reason, we did a simulation based performance analysis of the AVB standard in a worst case situation with maximum six switches in a daisy-chain based switched Ethernet network.

This work is structured as follows. In Section 2 we present similar research studies and point out the differences to our work. Section 3 describes the IEEE 802.1 AVB standard with the main mechanisms and sub-standards. In Section 4 we describe the simulation models of the AVB protocols and introduce our performance evaluation with the system model and traffic characteristics. The final Section 5 summarizes and concludes our work.

## 2. RELATED WORK

The previous works related to the IEEE 802.1 AVB evaluation considered only a single mechanism of the AVB standard. J.Imtiaz et al. [12] compared the credit based queuing (CBQ) mechanism of the IEEE 802.1Qat with the priority based queuing in an Ethernet network. Based on a worst case analysis, they showed that the worst case delays for all real-time messages with the CBQ are better predictable. M.J. Kim et al. [14] and Y.-D. Choi[9] et al. also analyzed the queuing and forwarding rules as specified in IEEE 802.1Qat. The first work proposed a superframe forwarding concept where different data classes are transmitted within

a certain cycle time, while the second work introduced a fairness between AVB and non-AVB data.

Other works investigated the AVB standard for the use in an industrial automation network by modifying the AVB standard [15, 13]. O.Kleineberg et al. [15] proposed and evaluated the concept for achieving a redundancy in an AVB network, while J.Imtiaz et al. [13] introduced a mechanism to integrate the industrial process data communication to the lower layer services of IEEE 802.1 AVB.

In this paper, we want to verify the requirements for time-aware applications with IEEE 802.1 AVB by using all of the specified protocols in a worst case scenario with a maximum number of seven hops from the source node to the sink node. Another important aspect of this work is the verification of the robustness of an AVB network for time-aware applications.

### 3. IEEE 802.1 AUDIO/VIDEO BRIDGING

The IEEE Audio/Video Bridging Task Group [11] specifies different mechanisms to provide time-synchronized low latency streaming services through 802 networks. These mechanisms are based on a Medium Access Control (MAC)-Layer to support guaranteed QoS in a switched Ethernet network or IEEE 802.11 WLAN. An overview of the specified protocols compared to the legacy mechanisms in a switched Ethernet network is given in figure 1. These protocols are required to guarantee a worst case latency that a stream experiences in a transmission between a source node (“*Talker*”) and a sink node (“*Listener*”). In case of a switched Ethernet network with 100Mbit/s links and a frame of an AVB stream reservation class (SR-Class) A, a latency of 2ms for maximum number of seven hops is guaranteed [8]. In addition to the guaranteed latency of AVB data, the synchronization accuracy is less than  $1\mu\text{s}$  over seven hops [7].

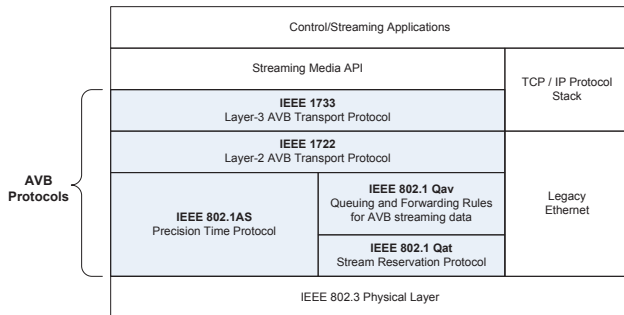

Figure 1: Overview of the IEEE 802.1 Ethernet AVB

In this work, we focus on the evaluation of the Ethernet AVB mechanisms which are mostly ratified and published in 2011. In the following sections, we give an introduction of Ethernet AVB with the specified protocols.

#### 3.1 IEEE 802.1AS

The base for time-sensitive communication is a precise timing and synchronization over all participating distributed network nodes. The distributed nodes are synchronized to have a common reference time mainly for two purposes. At first, a common time base has to be provided for streaming data at a source node in order to present them to the destination node with the same timing information. Secondly, multiple streaming data are able to be synchronized

by using the protocol. For this reason, IEEE 802.1AS [7] specifies Layer-2 synchronization services to meet the high requirements of Audio/Video (A/V) applications. The synchronization process based on the IEEE 802.1AS standard is executed in two steps.

##### 1. Selection of a grandmaster node.

A single node in a network is selected as a grandmaster (GM) node with the best clock by the best master clock algorithm (BMCA). This algorithm determines a spanning tree for the synchronization and sets the grandmaster as its root (see Fig. 2). Furthermore, it identifies time-aware systems which are able to support the IEEE 802.1AS protocol. After the BMCA is executed all ports of the nodes are assigned to one of the following port roles: *master*, *slave*, *disabled* and *passive* port.

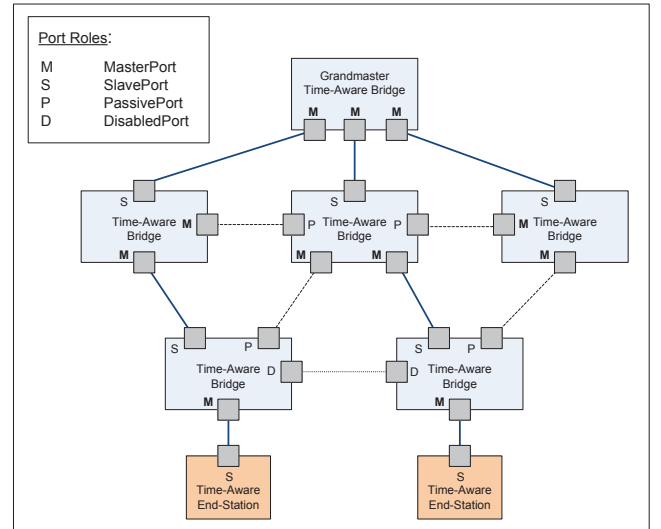
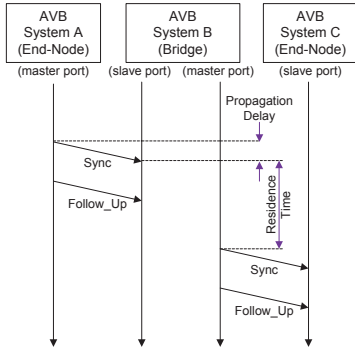

Figure 2: Resulting Spanning Tree by the BMCA [16]

##### 2. Synchronization of distributed nodes.

After the BMCA is executed and the GM is selected as the root, the synchronization information is transmitted from the master ports of GM to all slave ports of the directly connected AVB systems. The intermediate systems adjust and correct the information by considering the propagation delay, residence time and forward it along to the path determined by the BCMA. The propagation delay is a time taken by a message between two directly connected systems which is measured in each port of every full-duplex point-to-point link. The residence time is the forwarding delay which is required to transmit a synchronization message by a time-aware bridge to the next one (see Fig 3). The synchronization information is distributed to the network by using two message types: *Sync* and *Follow-Up*. The *Sync* message is a synchronization information with an approximated time, while the latter one contains the correction value for the *Sync* message, to allow an adjustment of the previous information and results in an improvement of the accuracy. The correction is performed for all intermediate and end systems



**Figure 3: Synchronization between three time-aware systems**

in a network.

After several synchronization messages, the clock drift between the GM and local clock of each systems is known, so that the drifts are corrected and all AVB systems are synchronized. The IEEE 802.1AS specifies a synchronization accuracy of less or equal than  $1\mu\text{s}$  between seven or fewer hops in a switched Ethernet network [7].

### 3.2 IEEE 802.1Qat

An allocation of the network resources (e.g. required bandwidth, maximum latency) for a specific streaming data over a switched Ethernet network is required to ensure that the QoS requirements are met. For this reason, the IEEE 802.1Qat defines a signaling protocol to allow an end-to-end management of resource reservation which is specified as a stream reservation protocol (SRP) [5]. This standard is used to register or de-register a specific streaming application to allocate or release a bandwidth in a whole AVB network. The signaling protocol is only used for AVB streaming data, where two different stream reservation (SR) classes are defined: SR-Class A and SR-Class B. The difference between the two SR classes is the worst case latency requirement over seven hops in a network (SR-Class A: 2ms, SR-Class B: 50ms). Furthermore, the bandwidth allocated for both SR classes is limited to maximum 75% of the total bandwidth, so that a total maximum bandwidth of 75Mbit/s is reserved for AVB frames in a switched Ethernet network with 100Mbit/s links. The rest of the link bandwidth which is at least 25% of the capacity is used for legacy non-AVB Ethernet frames.

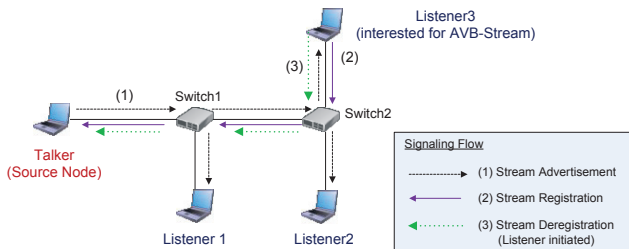

**Figure 4: Signaling Process based on IEEE 802.1Qat**

The signaling process based on the IEEE 802.1Qat is executed by the following three steps (see Fig. 4).

#### 1. Stream Advertisement.

In a first step, the talker generates a *talker advertise frame* with the provided traffic specifications (TSpec) such as the *StreamID*, *MaxFrameSize* and *MaxIntervalFrames*. The frame is transmitted to the AVB network by multicast and each of the intermediate switches are able to calculate the required bandwidth with this information. The *StreamID* is a unique identifier for a specific stream in order to distinguish different streams in a network which consists of a talker MAC address and a unique identifier. The *MaxFrameSize* (*MFS*) indicates the maximum payload size of each frame transporting the stream while *MaxIntervalFrames* (*MIF*) gives information about the amount of frames in each interval time. The required bandwidth of a streaming data (*StreamBW*) at each port of intermediate switches is calculated by using equation 1.

$$\text{StreamBW} = \frac{(MFS + OH) \cdot MIF}{\text{IntervalTime}} \quad (1)$$

The overhead of a streaming frame (*OH*) is 42 bytes and includes the Ethernet header, preamble, CRC and IFG. The interval time depends on the used AVB streaming class which is determined by the used priority value in a VLAN tag as specified in the IEEE 802.1Q standard (see Tab. 1).

**Table 1: AVB Stream Classes with the Interval Time**

AVB Stream Class	Priority Value	Interval Time [ $\mu\text{s}$ ]
A	3	125
B	2	250

After the *StreamBW* is calculated and the output port of a switch has enough resources, the frame is forwarded without any modifications to the port. In the other case, when no sufficient resources are available, the frame is modified to *talker failed frame* with a failure information and it is forwarded to the listeners.

#### 2. Stream Registration.

After a *talker advertise frame* is received by a listener and it does not contain any failure information, the listener can decide to register and subscribe the provided stream. In this case the listener generates and transmits a *listener ready frame* to the talker in order to register to the specific streaming data and to allocate the required bandwidth along the entire path from the listener to the talker. In case of some capacity problems of a bridge, the frame is modified to *listener asking failed* in order to inform the previous switches that there are no sufficient bandwidth at that port.

#### 3. Stream De-Registration.

The delivered streaming data provided by a talker is stopped by a talker or a listener.

##### (a) Initiation by a source node (“Talker”).

A specific stream delivered by a talker can be stopped at any time by transmitting a *de-register stream frame* with a *streamID* from a talker to the listeners. This frame indicates that the stream is

not provided by a talker and it is forwarded by switches to the subscribed listeners. The switches in a network release the bandwidth reservations and allocations of the specific stream.

- (b) Initiation by a destination node (“Listener”). A specific stream subscribed by a listener can be de-registered at any time. The listener generates and transmits a *de-register attach frame* to the talker and each switch along the path in a network releases the bandwidth reservations at the ports.

### 3.3 IEEE 802.1Qav

The IEEE 802.1Qav standard specifies mechanisms to provide guarantees for time-sensitive (i.e. bounded latency and delivery variation), loss-sensitive real-time audio video (AV) data transmission (AV traffic) [4]. It allows a separation of the network traffic into different traffic classes by using priority mechanisms as specified in the IEEE 802.1Q standard [3]. The IEEE 802.1Qav standard specifies mainly two mechanisms to achieve guaranteed QoS in a switched Ethernet network which are described in the following sections.

#### 3.3.1 Re-Mapping of priority values to AVB Classes

IEEE 802.1Q specifies eight different traffic classes in a switched Ethernet network by using Virtual Local Area Network (VLAN) tag encoded priority values in an Ethernet frame. Each of the traffic classes has an own output queue and the priority values are varied between 0 and 7, where the highest traffic class is set with the highest priority value. The IEEE 802.1Q standard recommends a mapping of the priority values to the queues depending on the available queues and traffic classes in a network. The IEEE 802.1Qav standard extends the mapping rules by considering AVB frames (SR-Class A and SR-Class B) in a network. A re-mapping of the priority values is required to achieve that AVB frames have the highest two priority values in a network. Figure 5 shows the recommending mapping rules of priority values 3 and 2 for SR-Class A and SR-Class B frames depending on the total available traffic classes and queues.

		Number of Available Traffic Classes						
		2	3	4	5	6	7	8
Priority	0 (Default)	0	0	0	0	0	0	1
	1	0	0	0	0	0	0	0
	2	1	1	2	3	4	5	6
	3	1	2	3	4	5	6	7
	4	0	0	1	1	1	1	2
	5	0	0	1	1	1	2	3
	6	0	0	1	2	2	3	4
	7	0	0	1	2	3	4	5

Figure 5: Recommended mapping rules between VLAN tagged priority values and AVB Classes (SR-Class A and B) [4]

#### 3.3.2 Transmission selection algorithms

IEEE 802.1Qav specifies the use of different scheduling mechanisms to enable a transmission of AVB and non-AVB legacy Ethernet frames in a switched Ethernet network: *strict*

*priority* and *credit based shaper* transmission selection algorithm.

##### 1. Strict Priority Selection

The strict priority transmission (SP) selection algorithm is used as the default algorithm to select legacy Ethernet frames for transmission. It should be supported by all switches in a network and the frames are selected by their priority values. At first, legacy Ethernet frames are selected from the highest priority non-AVB queue until the queue is empty and frames from other non-AVB queues are selected successively based on the priority values.

##### 2. Credit Based Shaper Selection

The credit based shaper (CBS) transmission selection algorithm is used in order to select AVB frames for the transmission. The algorithm defines credits associated to each of the SR classes (Class-A, Class-B) where a transmission is only allowed when the credits given in bits are greater or equal than zero and no other frames are transmitted at the same time (*no conflicting frames*). In this case, an AVB frame is dequeued and transmitted where the credits are decreased at a rate of a *sendSlope*. In the other case, the credits are increased at a rate of *idleSlope* and a frame from the SR-Class is not transmitted. The algorithm limits the maximum and minimum number of credits that can be accumulated by using the parameters *hiCredit* and *loCredit*.

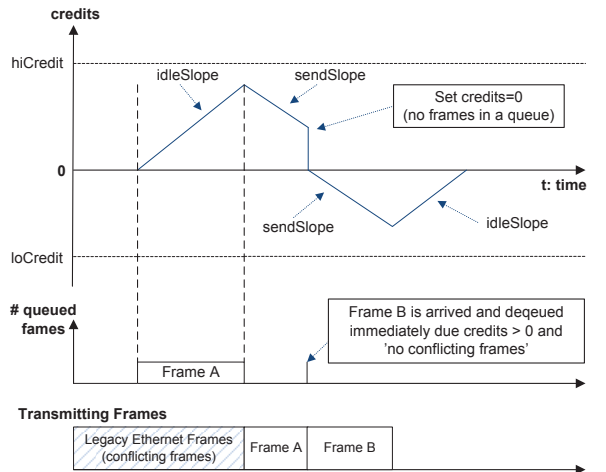

Figure 6: Credit based shaper (CBS) operation

Figure 6 shows an example which describes the operation of a CBS algorithm. In a first step, a single AVB frame (“Frame-A”) arrives and is queued due to conflicting frames. The credits are increased by a rate of *idleSlope* and the frame is selected for the own transmission as soon as the previous transmission is finished. The credits are decreased by a rate of *sendSlope* when the frame is transmitted. The credits are set to zero when no frames exist for transmission for a given SR-Class queue so that the algorithm has to wait for the next transmission. In a next step another AVB frame (“Frame-B”) arrives and it is transmitted

immediately due to the credit values ( $\geq 0$ ) and no conflicting frames. The credits are decreased by a rate of *sendSlope* and they are increased by *idleSlope* after the complete transmission. Furthermore, there is a fixed interval time where an AVB frame is transmitted depending on the AVB streaming class (A,B). The interval for an AVB SR-Class A frame is  $125\mu\text{s}$  while it is  $250\mu\text{s}$  in case of an AVB SR-Class B frame (see Tab. 1).

### 3.4 IEEE 1722

The IEEE 1722 is a Layer-2 transport protocol that allows a particular encapsulation of audio and video frames in order to ensure and meet the QoS requirements. The protocol allows time stamping of the frames indicating the receiver node to play the information at the exact playing time. IEEE 1722 ensures the synchronization between different listeners connected to a given streaming data in combination with the time synchronization protocol IEEE 802.1AS. Figure 7 shows the 1722 Audio/Video transport protocol (AVTP) in an AVTPDU header format which transports the AVB frames.

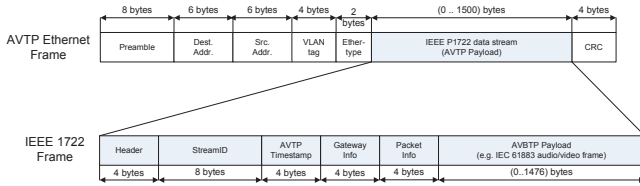

Figure 7: IEEE 1722 Audio/Video Transport Protocol (AVTP)

AVB streaming data are transported by an IEEE 1722 frame specified as the *AVBTP payload*, where the maximum frame size is limited to 1476bytes. In addition to the payload, other information such as the *Header*, *StreamID*, *AVTP Timestamp*, *GatewayInfo* and *PacketInfo* are included and encapsulated by an Ethernet frame (see Fig. 7). *StreamID* is used to identify a stream and to distinguish different provided streaming data. The *AVTP Timestamp* information contains the presentation time of a frame. It represents the timestamp when the media sample was presented to AVTP at the Talker plus a constant, *Max Transit Time*, to compensate for network latency [6]. The *Max Transit Time* represents the worst case network latency assumed for a given configuration which depends on the requested SR-Class of the given stream. The AVB task group specifies two default values of *Max Transit Time* depending on the SR classes.

- SR-Class A: *MaxTransitTime* = 2ms .
- SR-Class B: *MaxTransitTime* = 50ms .

The *GatewayInfo* field is reserved for the use of AVTP gateways which are not defined by IEEE 1722 while the *PacketInfo* field gives information about the payload such as the payload length and used protocol specific header.

## 4. PERFORMANCE ANALYSIS OF IEEE 802.1 ETHERNET AVB

For the performance analysis of the IEEE 802.1 Ethernet AVB standard with all the specified protocols we choose a simulation approach due to the limited availability of AVB capable hardware prototypes. We use the network simulation tool OMNeT++ [2] with the INET-framework [1] which already contains the implementations of the common network protocols such as Ethernet, IPv4, TCP/UDP. The INET-framework has been extended with the AVB protocols IEEE 802.1AS, IEEE 802.1Qat, IEEE 802.1Qav and IEEE 1722. The simulation framework with the Ethernet AVB support will be published soon.

### 4.1 Modeling in OMNeT++

#### 4.1.1 IEEE 802.1AS

One of our major goals was to integrate the IEEE 802.1AS protocol as part of the INET-framework. The IEEE 802.1AS architecture divides a time-aware system in a media-dependent and media-independent entity. All components are placed at Layer-2 (link layer) above the IEEE 802.1 medium access control (MAC) [7]. The INET-framework is structured accordingly to the ISO/OSI network layers and allows an integration similar to the IEEE 802.1AS specification. Figure 8 illustrates the integration architecture of our simulation model within the INET-framework.

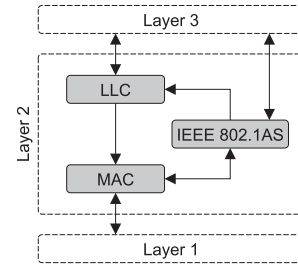

Figure 8: Integration of the IEEE 802.1AS simulation model within the INET-framework

All messages received by the MAC sub-layer are redirected to the IEEE 802.1AS module. If the received message is an IEEE 802.1AS message it is handled by this module. In any other case, the frame is forwarded to the higher layers. The protocol module has access to the MAC to transmit protocol specific messages. The synchronized time is made public by the IEEE 802.1AS module, which is accessible for Layer-2 and Layer-3 services. This integration is generic and can be used both in an end-station (host) and switch.

#### Passive Clock Approach.

One of the great challenges was the integration of an asynchronism between distributed network nodes, which is present in real networks. In a discrete event based simulation environment all network nodes are internally synchronized by the simulation time. In the reality, each time-aware system (host, switch) has an own free running clock. We introduce a certain asynchronism between the nodes in a network by modeling a passive clock implementation in the INET-framework. This approach is selected to avoid negative influence to the simulation performances. The passive

clock approach operates and determines the time only by a request, where following parameters can be set to configure the asynchronism.

- Clock frequency / tick interval – The speed of a clock is determined by its tick interval (e.g. 25MHz  $\rightarrow$  40ns).
- Tick interval asynchronism – Define a phase discontinuity between two network nodes.
- Total time offset – Simulate different power-on times.
- Clock drift – The frequency variance of different oscillators is modeled by a constant drift value (random number). In reality, additional clock drift over a time occurs due to temperature changes, but this effect is not considered in our simulation model.

### Modules.

The IEEE 802.1AS standard is mainly implemented by two modules: *etherPort802\_1AS* and *ieee802\_1AS* module. The first module represents the MAC sub-layer while the second one contains the IEEE 802.1AS mechanisms. Figure 9

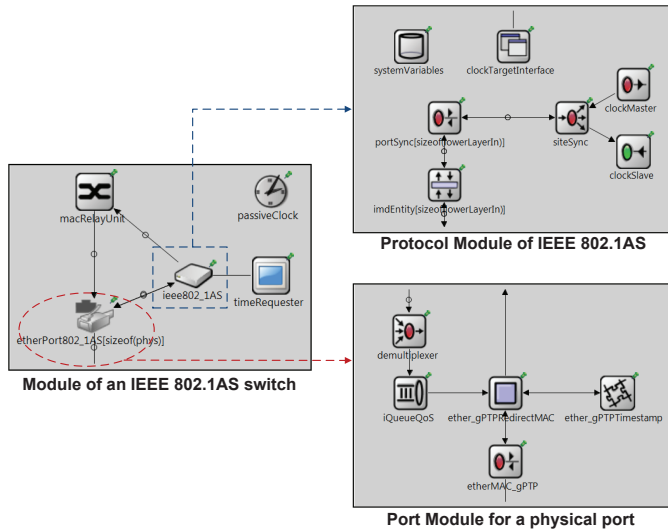

**Figure 9: Modules of the IEEE 802.1AS**

shows the two modules in an IEEE 802.1AS switch which is designed to support a dynamic amount of physical ports. For each port there is a port module, the media-dependent submodule within the *ieee802\_1AS* protocol module and the interconnections are generated automatically. This architecture allows an easy integration in a network, because no further configuration is necessary. The switching functionality is performed by the *macRelayUnit* module based on the INET-framework. In contrast to a switch, an end-station has only one physical port, so that a network interface card (NIC) is realized in a similar way, where the connection to the higher layer is done by *etherEncap* instead of using the *macRelayUnit* module. This INET module has been modified slightly to perform the necessary conversion between Layer-2 and Layer-3 messages. Each time-aware system contains exactly one passive clock module. The time requester module in Fig. 9 demonstrates a Layer-2 service that requests the synchronized time, provided by the IEEE

802.1AS mechanism. The synchronized time base can be requested via an interface by Layer-2 and Layer-3 services. The two modules to perform the IEEE 802.1AS mechanism are described as follows.

#### 1. Port module: *etherPort802\_1AS*

The port module in the NIC and switch represents the MAC sub-layer. It contains the different priority queues and includes the IEEE 802.1AS timestamp correction function. The priority queue module is an interface to allow different queue implementations. All messages which need to be sent are stored in the priority queues. The *etherMAC\_gPTP* module is derived from the *etherMAC* module of the INET-framework and requests the next frames to be sent on the connection. If IEEE 802.1AS messages are sent or received they are redirected to the *ether\_gPTPTimestamp* module which corrects the timestamp of the message to the reference plane of the network node.

#### 2. Protocol module: *ieee802\_1AS*

The protocol module contains the most significant functional parts of the IEEE 802.1AS mechanism. It includes media-dependent and media-independent parts of the IEEE 802.1AS standard. The media-dependent part is implemented as an interface (*imdEntity* module), to allow a dynamic assignment of the transport media functionality. All other modules within this structure represent media-independent operations. The media-dependent entity receives all messages from the MAC sub-layer and redirects only IEEE 802.1AS message for further processing within this module. All other network messages are forwarded to the higher layers. This implementation ensures that the INET functionality is preserved and higher layers have no knowledge of the IEEE 802.1AS operation. For each port it is necessary to have a MDEntity and a PortSync module connected to the SiteSync module. Our design automatically creates the necessary modules and interconnections, based on the amount of connections to the switch. The IEEE 802.1AS mechanism is handled by the PortSync, SiteSync, ClockSlave and ClockMaster modules. The module *clockTargetInterface* is the access point for other services to provide the synchronized time. General information about the network status and network node are stored in the *systemVariables* entity.

### 4.1.2 IEEE 802.1Qat/Qav

#### Modules.

The signaling protocol IEEE 802.1Qat is used to reserve the required resources for time-sensitive AVB streaming data. This protocol is modeled as a compound module in combination with the forwarding and queuing rules as specified in the IEEE 802.1Qav standard (see Fig. 10).

The IEEE 802.1Qat is used to announce an AVB streaming data with its traffic specifications (TSspec) by multicast and to register and de-register the specific streaming data. The announcement is initiated by the talker with the *applicationEntity* and the *MSRP* module. The *applicationEntity* decides to advertise a stream or to stop the providing streaming service at a talker. At the listener side, it can decide to register or cancel its subscribed streaming service. The *MSRP* module translates the requests of the

*applicationEntity* where it converts the request into a Qat-frame before sending the frame to the physical layer. The *etherEncap* component is responsible of the encapsulation of the streaming reservation information in an Ethernet frame. The *redirect* component allows the use of other applications for end-stations and it verifies if the received frame is destined for the AVB modules by checking the EtherType field in an Ethernet frame header.

A switch with the IEEE 802.1Qat/Qav features is modeled quite differently. At first, there is a *redirect\_Switch* component which permits the integration of the AVB modules to the model in the INET-framework. It filters AVB frames and sends them to the *etherEncap* component while a non-AVB legacy Ethernet frame is sent to the *macRelayUnit*. The *map* (*MSRP Attribute Propagation*) component processes the AVB frames, calculates the required bandwidth and decides to forward them. Furthermore, it gives information about the ingress port of the streaming data at a talker side and the egress ports at the listener sides to the *reservation* component of a port module if the reservation process is successfully performed. If it receives a message by indicating a de-registration of a specific stream initiated by a talker or a listener, the *reservation* component is updated and the related entries are released.

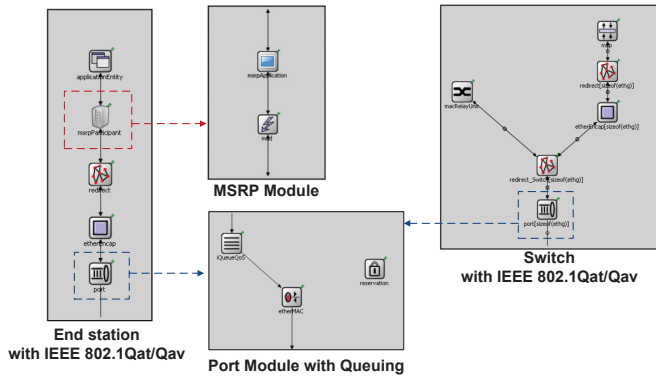

Figure 10: Modules of the IEEE 802.1Qat/Qav

The IEEE 802.1Qav standard is implemented in a port module as described in Figure 10, where the two transmission selection algorithms (strict priority, credit based shaper) are implemented by the *iQueueQoS* module. The frames from the higher layer are enqueued to the appropriated queue by using the priority values and the EtherType. This module triggers stream reservations from the *reservation* component to evaluate the values of the different parameters previously defined and calculates the credits of each traffic class queue. The *reservation* module contains information about the bandwidth reservation on that port: the rate of bandwidth allocated to SR classes A and B and the IDs of the corresponding streaming data.

An incoming frame from the lower layer is treated directly in the *etherMAC* module to check if they have the right MAC destination address. The frame is delivered to the higher layer if the destination address is correct, otherwise it is ignored and removed. This module is already implemented in the INET-framework.

### 4.1.3 IEEE 1722

#### Modules.

The IEEE 1722 module as represented in Figure 11 describes the behavior of a switch for handling IEEE 1722 frames by the component *streamRelay2*. It receives an AVTP frame and requests the *map* component of the IEEE 802.1Qat/Qav module about the egress ports for the frame (see Fig. 12). This frame is forwarded to the right egress ports when the stream is already registered and it is dropped if the frame does not belong to a registered stream.

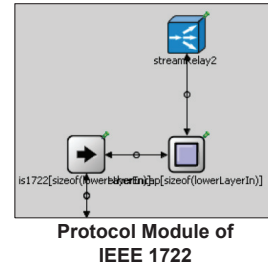

Figure 11: IEEE 1722 protocol module

### 4.1.4 IEEE 802.1 Ethernet AVB

#### Modules.

One of the challenges by modeling the AVB standard was to implement the protocols in modules which should be modularly structured. A complete AVB capable NIC and switch are built by compounding the modules of the AVB protocols. Figure 12 shows an AVB switch where the main protocols (IEEE 802.1AS, IEEE 802.1Qat/Qav, IEEE 1722) are modeled by the *l2protocol* module. The IEEE 802.1AS, IEEE 802.1Qat/Qav and IEEE 1722 components are the modules which are introduced in the previous sections.

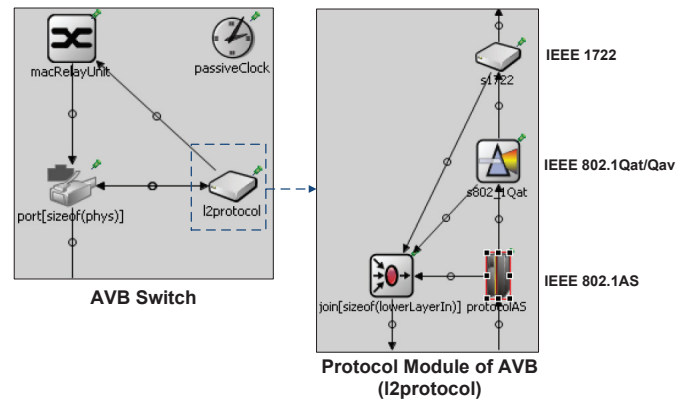

Figure 12: Modules of an AVB Switch

## 4.2 Goals of the Analysis and Metrics

Our work should verify the requirements of time-sensitive AVB applications in a switched Ethernet network. Following aspects are considered and analyzed in this work.

- The application constraints in terms of the *latency*, *jitter* and *packet loss rate* of AVB streaming data should

be guaranteed by using the IEEE 802.1 Ethernet AVB standard. In this work, we will verify the requirements in a worst case scenario with seven hops in a daisy-chain and additional background load in a network. In details we consider the following research questions.

- Does the payload size of an AVB frame ( $MaxFrameSize$ ) have an influence on the application performance?
- Can we guarantee the AVB requirements even in high load situations?
- What is the synchronization accuracy at different listeners for AVB streaming data?
- In addition to the AVB streaming data, control data is considered as another traffic class in order to determine the influence of the AVB standard to other traffic classes. The control data is transmitted by legacy Ethernet frames with the highest priority class of non-AVB data.

### 4.3 System Model

#### 4.3.1 Topology and Scenario

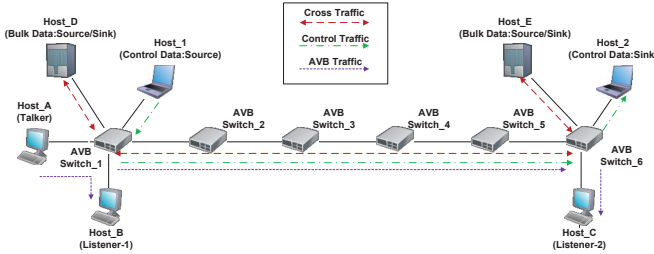

Figure 13: System Model of an AVB network

We choose a daisy-chain based topology with six AVB switches and three AVB end-stations to consider the worst case situation with seven hops in an AVB network (see Fig. 13). The talker (“*Host\_A*”) is connected to the first AVB switch while the listeners (“*Host\_B*”, “*Host\_C*”) are connected to the first and last switches. In addition to the AVB nodes, there are other nodes in order to transmit control data and additional bulk data to the network. We build two scenarios in the same network to analyze and verify the AVB protocols to the provided applications.

- Scenario-1: Network with only AVB streaming nodes. In this scenario, there are only a single talker and two listeners in the network. In a first part of the analysis, the AVB streaming data modeled as SR-Class A frames are only transmitted to the network by using different payload sizes for AVB frames. The second part transmits only SR-Class B frames in a network.
- Scenario-2: Network with additional background load. In a first part of the analysis, we transmit only an AVB streaming data modeled as SR-Class A with a medium payload frame size of 500byte. In combination with the AVB data, additional bulk data are transmitted from the end-stations at both side of the daisy-chain topology to the network which are considered as cross traffic. Furthermore, control data which are modeled

as legacy Ethernet frames are transmitted over seven hops to determine the influence of the additional cross traffic to the application performances.

#### 4.3.2 Assumptions and Traffic Characteristics

The following assumptions are used for the performance analysis of the AVB network.

- IEEE 802.3 full-duplex links with 100Mbit/s – The IEEE 802.1 AVB standard requires links which are able to support at least 100Mbit/s [8]. We used 100Mbit/s links to determine the limits based on the current standard technology.
- Static clock drifts of the nodes without the BMCA – The clock drifts of each nodes are set manually and the grandmaster is set to the talker node so that the BMCA is not performed.
- IEEE 802.1Qav queuing rules – Totally six different traffic classes and queues are used, where two of them are used for AVB classes (SR-Class A, SR-Class B) which are scheduled and transmitted by the CBS algorithm. The remaining four classes are used to transmit legacy Ethernet frames scheduled by the SP algorithm. The last two priority values can be used for other traffic classes but they are not used in our analysis.

The traffic characteristics with the Ethernet payload size, sending rate and priority value of each traffic classes are described in Tab. 2.

Table 2: Traffic Characteristics

Traffic Type	Ethernet Payload Size [byte]	Sending Rate [ms]	BW [Mbit/s]	Prio
AVB	Low: 125	0.125	10.688	Class A (Prio 5)
	Medium: 500	0.125	34.688	
	High: 1000	0.125	66.688	
AVB	Low: 125	0.250	5.344	Class B (Prio 4)
	Medium: 500	0.250	17.344	
	High: 1000	0.250	33.344	
Control	46	uniform (10,100)	<0.07	Prio 3
Bulk	Low: 125	0.250	5.344	Prio 2
	Medium: 700	0.250	23.744	
	High: 1500	0.250	49.344	
	1500	0.2467	50	
		0.2056	60	
		0.1898	65	
		0.1762	70	

## 4.4 Results

#### 4.4.1 Scenario-1: Only AVB streaming nodes in a network

The  $MaxFrameSize$  of an AVB frame increases the required bandwidth of the streaming data in an AVB network due to the fixed sending rate and variable frame size. The different payload sizes of AVB frames influence the performances in terms of the latency, jitter and packet loss rate (see Tab. 3), but there are no differences between the AVB classes (SR-Class A, SR-Class B). Both AVB classes have

Table 3: Influence of the MaxFrameSize for AVB frames over 7 hops without additional load (Scenario-1)

MaxFrameSize [byte]	Max. Latency [ $\mu$ s]		Max. Jitter [ $\mu$ s]		Packet Loss Rate	
	SR-Class A	SR-Class B	SR-Class A	SR-Class B	SR-Class A	SR-Class B
125 (low)	115.775	114.460	0.526	0.532	0	0
500 (medium)	335.003	329.947	0.440	0.485	0	0
1000 (high)	615.023	606.389	0.521	0.488	0	0

Table 4: Influence of additional background load (Scenario-2)

Additional Load [%]	Max. Latency [ $\mu$ s]			Max. Jitter [ $\mu$ s]			Packet Loss Rate		
	SR-Class A		Control	SR-Class A		Control	SR-Class A		Control
	Listener-1	Listener-2		Listener-1	Listener-2		Listener-1	Listener-2	
0	95.101	326.555	252.941	0.241	0.295	166.872	0	0	0
50	93.402	767.693	854.735	0.401	0.513	363.860	0	0	0
60	91.543	768.086	856.550	0.358	0.388	353.272	0	0	0
65	94.386	784.005	854.075	0.175	0.316	358.257	0	0	0
70	94.396	815.640	874.833	0.177	0.486	312.756	0	0	0

a maximum latency less than 1ms and maximum jitter less than  $1\mu$ s over seven hops. In both cases the latency requirements of 2ms for SR-Class A and 50ms for SR-Class B over seven hops are met in this scenario.

#### 4.4.2 Scenario-2: Influence of additional network load

The network load has only a small influence on the application performance in terms of the latency, jitter and packet loss rate of AVB streaming data over seven hops (see Fig. 14 and Tab. 4).

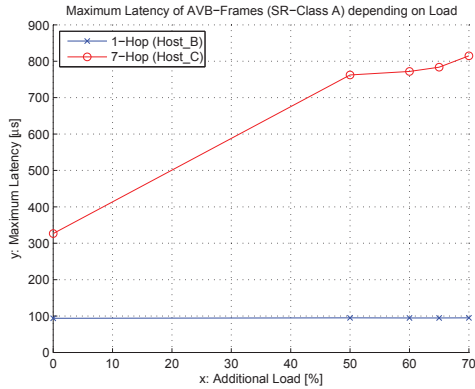

Figure 14: Maximum latency of AVB data depending on the network load

Even in a very high load situation, when the link is occupied by close to 100%, the latency of time-sensitive AVB streaming data is less than the specified value of 2ms and the jitter is negligible. The latency of control data which are transmitted as legacy Ethernet frames of the non-AVB class are also not highly influenced by the network load due to higher priority values of control data. Most of the packet losses are occurred by the bulk data which are transmitted with the lowest priority value of non-AVB class. Compared to the streaming data, the control data have higher latency and jitter values due to the scheduling and prioritization mechanism of the IEEE 802.1Qav standard. The non-AVB data frames are lower prioritized than AVB data frames and

they are only allowed to transmit when the AVB credits are less than zero.

Figure 15 shows the difference of the media presentation time at different listeners which represents the synchronization accuracy. The synchronization accuracy is increased with higher network load but the synchronization accuracy requirement of  $1\mu$ s over seven hops is not violated in different network load situations.

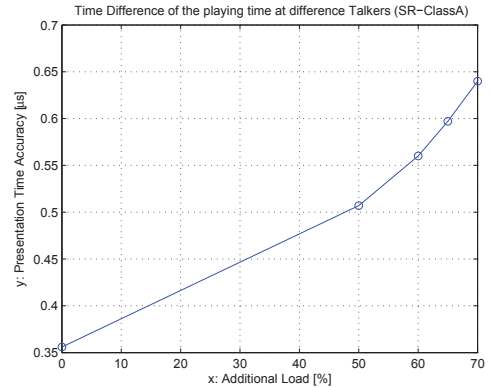

Figure 15: Presentation time difference at different listeners depending on the network load

## 5. SUMMARY AND CONCLUSION

In this work we presented and evaluated the IEEE 802.1 Audio/Video Bridging (AVB) standard with the following specified protocols.

- IEEE 802.1AS – Time Synchronization Protocol.
- IEEE 802.1Qat – Stream Reservation Protocol for time-sensitive AVB frames.
- IEEE 802.1Qav – Forwarding and Queuing rules for AVB frames.
- IEEE 1722 – Transport Protocol for AVB frames.

A simulation approach is used for the performance evaluation due to the limited availability of AVB capable switches and end nodes. We selected a worst case scenario with seven hops in a switched Ethernet network to verify the constraints of the time-sensitive applications modeled as AVB streaming data (SR-Class A, SR-Class B) in terms of the *latency*, *synchronization accuracy* and *packet loss rate*. Furthermore, the influence of additional background load is considered in this analysis. The performance evaluation of the AVB standard shows:

- The payload size of AVB frames (*MaxFrameSize*) influences the application performance. The latency of AVB streaming data is improved by reducing the *MaxFrameSize*. There are no quite differences between the modeled AVB classes. In case of the latency both AVB SR-Classes have same results, but the maximum jitter is improved by using AVB SR-Class B frames.
- The application constraints in terms of the maximum latency and synchronization accuracy over seven hops for AVB streaming data are guaranteed even in high network load situations. The analysis shows the latency requirement of 2ms and the synchronization accuracy of 1 $\mu$ s over seven hops are met in all situations.
- Control data transmitted as legacy Ethernet frames with the highest priority of the non-AVB class is not highly influenced by the network load. The latency of less than 1ms is achieved in all network load situations.

For the future work we will validate our worst case analysis with the seven hops scenario by hardware prototypes. Additionally, more different traffic classes are considered to provide different applications in an AVB network. Different topologies will be used in an AVB network and especially a specific topology in a vehicle network is selected in our further research path.

## Acknowledgments

Some of the research presented here, took place within the project SEIS – Security in Embedded IP–based Systems [10]. SEIS explores the usage of the Internet Protocol (IP) as a common and secure communication basis for electronic control units in vehicles. The project is partially funded by the German Federal Ministry of Education and Research (BMBF) (support codes 01BV0900–01BV0917). We would like to thank all SEIS partners directly or indirectly involved in our research.

## 6. REFERENCES

- [1] INET Framework for OMNeT++/OMNEST.
- [2] OMNeT++ Simulation Tool, Version 4.1.
- [3] IEEE Standard for Local and Metropolitan Area Networks Virtual Bridged Local Area Networks. *IEEE Std 802.1Q-2005 (Incorporates IEEE Std 802.1Q1998, IEEE Std 802.1v-2001, IEEE Std 802.1v-2001, and IEEE Std 802.1s-2002)*, pages 0\_1–285, 2006.
- [4] IEEE Standard for Local and Metropolitan Area Networks - Virtual Bridged Local Area Networks Amendment 12: Forwarding and Queuing Enhancements for Time-Sensitive Streams. *IEEE Std 802.1Qav-2009 (Amendment to IEEE Std 802.1Q-2005)*, pages C1–72, 5 2009.
- [5] IEEE Standard for Local and Metropolitan Area Networks—Virtual Bridged Local Area Networks Amendment 14: Stream Reservation Protocol (SRP). *IEEE Std 802.1Qat-2010 (Revision of IEEE Std 802.1Q-2005)*, pages 1–119, 30 2010.
- [6] IEEE Standard for Layer 2 Transport Protocol for Time Sensitive Applications in a Bridged Local Area Network. *IEEE Std 1722-2011*, pages 1–57, 6 2011.
- [7] IEEE Standard for Local and Metropolitan Area Networks - Timing and Synchronization for Time-Sensitive Applications in Bridged Local Area Networks. *IEEE Std 802.1AS-2011*, pages 1–292, 30 2011.
- [8] IEEE Standard for Local and metropolitan area networks—Audio Video Bridging (AVB) Systems. *IEEE Std 802.1BA-2011*, pages 1–45, 30 2011.
- [9] Y.-D. Choi, J.-W. Lee, S.-R. Ryu, and S.-H. Kim. A Forwarding Method on the IEEE 802.1 AVB. In *Proceedings of the 2008 International Conference on Advanced Language Processing and Web Information Technology*, pages 497–502, Washington, DC, USA, 2008. IEEE Computer Society.
- [10] eNOVA. SEIS: Security In Embedded IP-based Systems. <http://www.strategiekreis-elektromobilitaet.de/public/projekte/seis>.
- [11] IEEE 802.1 AVB Task Group. IEEE 802.1 Audio/Video Bridging (AVB). <http://www.ieee802.org/1/pages/avbridges.html>.
- [12] J. Imtiaz, J. Jasperneite, and L. Han. A performance study of Ethernet Audio Video Bridging (AVB) for Industrial real-time communication. In *Emerging Technologies Factory Automation, 2009. ETFA 2009. IEEE Conference on*, pages 1–8, sept. 2009.
- [13] J. Imtiaz, J. Jasperneite, and S. Schriegel. A proposal to integrate process data communication to IEEE 802.1 Audio Video Bridging (AVB). In *Emerging Technologies Factory Automation (ETFA), 2011 IEEE 16th Conference on*, pages 1–8, sept. 2011.
- [14] M.-J. Kim, Y.-S. Jang, M.-S. Jung, and S.-H. Kim. Frame Forwarding Rules for Link Utilization in IEEE 802.1 AVB Networks. In *Proceedings of the 2008 International Conference on Advanced Language Processing and Web Information Technology*, pages 509–512, Washington, DC, USA, 2008. IEEE Computer Society.
- [15] O. Kleineberg, P. Frohlich, and D. Heffernan. Fault-tolerant Ethernet networks with Audio and Video Bridging. In *Emerging Technologies Factory Automation (ETFA), 2011 IEEE 16th Conference on*, pages 1–8, sept. 2011.
- [16] H.-T. Lim, D. Herrscher, L. Völker, and M. J. Waltl. IEEE 802.1AS Time Synchronization in a Switched Ethernet Based In-Car Network. In *2011 IEEE Vehicular Networking Conference (VNC) (VNC 2011)*, pages 208–215, Amsterdam, The Netherlands, Nov. 2011.
- [17] H.-T. Lim, K. Weckemann, and D. Herrscher. Performance Study of an In-Car Switched Ethernet Network Without Prioritization. In T. S. et al., editor, *Nets4Cars/Nets4Trains 2011*. Springer-Verlag, 2011.