



Information Check and Control System of Substation Telemotor Based on Computer Vision

Wenwei Li^(✉)

Qinzhou Power Supply Bureau of Guangxi Power Grid Co., Ltd., Qinzhou 535019, China
zhangyongwei942@163.com

Abstract. Traditional verification methods require a large number of telecontrol signals as the basis, and it is difficult to detect the addresses of all regulatory information objects, resulting in inaccurate verification control results. For this purpose, this study designed a computer vision based substation remote motor information verification control system. In the hardware part of the system, a verification view module is constructed to present the data defined in the data model, a verification signature module is constructed to achieve information transfer between the verification side and the scheduling management side, and a verification network scheduling module is constructed to correct the monitoring point information on the work side. In the system software section, computer vision technology is used to identify the remote motor information of the substation. At the same time, encryption technology is introduced to prevent unauthorized users from stealing important information tables. Finally, design a scheduling master station simulation system to implement the motion machine information verification process and generate verification reports. According to the test results, it can be seen that the information configuration of the system is reasonable and the obtained information is valid, indicating that the effectiveness of the verification control is good.

Keywords: Computer vision · Substation remote motor · Information verification · Control system

1 Introduction

China's power grid companies have gradually started to implement the pilot construction of intelligent substations in 2009. The modeling and management of intelligent substation information model, model simulation, source end maintenance and other technologies are constantly developing, and intelligent substations are gradually entering the stage of comprehensive development. Intelligent substation automation system is widely used to achieve unified modeling and data exchange based on ICE standard. However, in the process of implementing intelligent substations, non-standard information models or misconfiguration will lead to communication errors in substations or problems in interactive operations. In the process of checking the monitoring information of intelligent substation, the shutdown of the data communication network, that is,

the telecontrol device, as the station control layer equipment, plays a key role [1]. The upper part can transmit the substation monitoring information in real time through the dispatching data network to ensure that the dispatching centers at all levels can monitor, control and adjust the substation, and the lower part can ensure that the equipment information can be obtained normally through the station control layer network, which is the key guarantee to realize the integrated operation of substation regulation. Therefore, how to improve the verification efficiency of substation telecontrol information between the main station end and the plant station end has become one of the difficulties in the engineering commissioning of intelligent substation monitoring system [2].

At present, the efficiency of checking the substation telecontrol information between the main station end and the plant station end is relatively low, and the method of manually operating point by point according to the monitoring information table is still used. The plant station end contacts the main station end by telephone to verify whether the monitoring information is correctly delivered. Checking the substation telecontrol information in this way causes a lot of waste of resources. At the same time, the verification of telecontrol information is often in the late stage during the commissioning stage of the entire intelligent substation project, which will inevitably increase the pressure on the substation commissioning and on-site commissioning personnel. Therefore, it is necessary to design an efficient and convenient telecontrol information quick verification system to improve the efficiency of monitoring information verification.

The traditional model verification only pays attention to the consistency test of the communication model, and ignores the data problems in the process of engineering use. In order to promote the standardization of engineering applications, the State Grid Corporation of China has proposed a secondary equipment model to meet the monitoring requirements of engineering application standards. Based on this, the rapid verification of the operation information of intelligent substation is realized, so as to effectively solve the problems in the verification process, and effectively improve the standardization level of the use of intelligent substation model engineering and the efficiency of model automation verification.

Based on the above analysis, this paper designs the information check and control system of substation remote motor based on computer vision.

2 Overall Structural Design of the System

The simulation master station in this system uses a secure and stable Linux operating system, obtains the IED model through the SCD file, and imports the telecontrol information point table into the simulation master station through Excel format. The analog master station communicates with the monitoring background and the telecontrol device through the MMS communication protocol, and realizes the automatic inspection of telecontrol information [3] by receiving the IEC 104 signal transmitted by the telecontrol device. The simulation master station can automatically record the action time, reset time and manual acceptance confirmation time (acceptance time) of the remote signaling point, and can monitor 104 “four remote” information messages in real time, and automatically generate an acceptance report after the test is completed.

In view of the problems existing in the operation of the monitoring background of the substation remote motor information check and control system, an independent network

protection monitoring unit is set in the background to realize the effective monitoring of the background data protection and remote control acquisition equipment, and improve the reliability and security of equipment operation [4, 5].

The network topology in the intelligent substation telecontrol information quick check station is shown in Fig. 1.

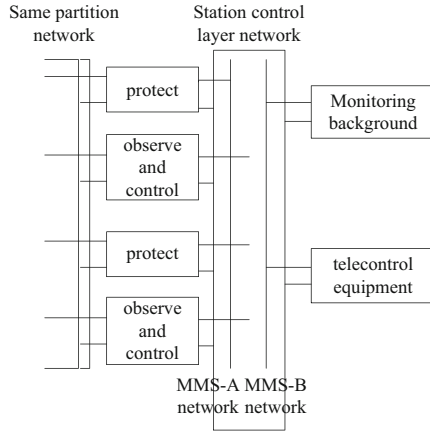

Fig. 1. Overall Structure Diagram of the System

The network protection monitoring unit consists of network protection monitoring software and network protection monitoring unit. Its function is to monitor the status, alarm, data analysis and recording of network layer equipment, effectively monitor the operation status of background data protection and remote control acquisition equipment, find problems in time, and provide accurate information for power grid faults through analysis and processing, prevent failure [6]. The designed telecontrol information quick check system is an open loop system, so the substation monitoring information can flow between the protection and monitoring device, the central switch at the station control layer, the telecontrol device, the dispatching data network, and the simulation master station.

The workflow of the telecontrol information quick check system is as follows: the “four remote” information of the relay protection device is submitted at the station terminal according to the point number of the ammeter; The data communication network shuts down the actual “four remotes” information of relay protection devices in the receiving station, and forwards it to the analog master station in the form of IEC104 message; After receiving the data forwarded by the communication network in the substation after shutdown, the analog master station automatically forms the master station record data table and checks with the monitoring background record [7]. This structure can effectively monitor the background data protection and remote control acquisition equipment, and has the characteristics of simple operation and strong practicability. It can ensure the normal operation of the background data protection and remote control acquisition equipment, greatly improving the working efficiency of operators, and also improving the reliability of substation equipment operation.

3 System Hardware Structure Design

The information checking system designed in this paper mainly includes the master station simulation system, motion devices, power protocol analyzer, and the scheduling of equipment in the substation bay.

The bay level protection device of the substation collects the data in the IED equipment, and uses the IEC communication protocol to send the operation data to the moving device [8]. The simulation system of the dispatching master station creates communication with the moving device, obtains the real-time data of the moving device by using IEC protocol, simulates the dispatching instructions issued, and provides the IEC message parsing function, and realizes the forwarding information test, software and hardware performance test, and information interaction function test [9] for the moving device of the tested object. The simulation system of the dispatching master station also has the ability of IEC communication. The power protocol analyzer uses IEC communication to connect the protection device, the simulation system of the dispatching master station and the measurement and control device, analyzes and compares the messages of the two in real time, and uses the information correspondence between the operation and movement of the automatic monitoring station terminal to enable the information collocation to carry out closed-loop management, ensure the reliability and accuracy of the calibration results.

3.1 Check View Module

The check view module refers to transmitting the remote machine information data of the substation to the remote machine information check converter through the remote machine information integration protection device and storing it in the memory. The check view module is an abstraction of this type of data, and applications can use the

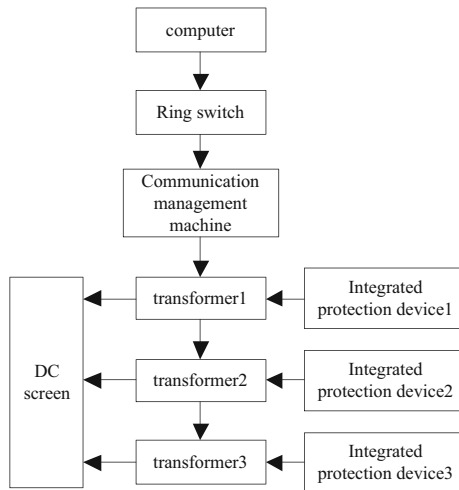

Fig. 2. Check view module

view module to process this data. For the design of remote machine information check view module, see Fig. 2.

Users can use the view to operate the application and realize interaction with the program. The view has a visual interface to display the data defined in the data model. Users can use the view to operate on the data and return the data operation results of the data model to the user. The user uses the view module to send an operation command to the communication management machine, and uses the remote machine information check converter to complete the transformation processing of the data model and definition according to the corresponding programming logic. At the same time, the transformation result is fed back to the user with the view [10].

3.2 Verification Signature Module

The verification signature module is an important component of the substation remote machine information verification control system. It is mainly used to sign and authenticate the verification results, ensuring the traceability of the verification process and the integrity of the data.

In the verification signature module, after each remote machine information verification, the system will automatically generate a verification report or record, which includes detailed verification results, timestamp, and relevant operator information. This information will be stored in the system's database for future reference and auditing.

Next, the verification signature module will generate a digital signature for the verification report or record, and can also provide signature verification functionality. By using a public key to decrypt a digital signature, the authenticity and integrity of the verification results can be verified, and any tampering or errors during the verification process can be confirmed.

Overall, the verification signature module plays an important role in the information verification control system of the substation's remote control system. It ensures the credibility of verification results and data integrity through digital signature and signature verification, while also providing traceability of the verification process. This provides important support for the safety management and audit of substations.

The design purpose of the verification signature module is to use the monitoring information table transmitted by the information transmission unit between the remote machine of the telecontrol substation and the communication management machine to exchange information between the customized sheet (that is, the monitoring information table) generated at the substation side and the dispatching management system, and obtain the verification signature information through the encryption and decryption unit. The module structure is shown in Fig. 3.

The check signature module mainly includes information exchange, information transmission, information encryption and decryption units. In this module, the transmission part mainly generates the monitoring information table at the substation side, which contains various monitoring information, equipment operation status points, equipment operation parameter points, equipment measurement parameter points, etc., it also includes equipment information (such as GIS equipment, SF6 transformer, circuit breaker hydraulic mechanism, protection device, measurement and control device, intelligent terminal, etc.), status information (such as accident information, knife switch

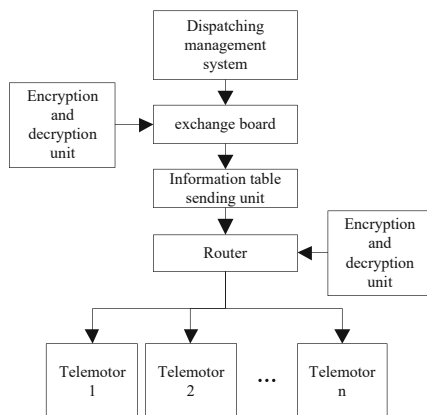

Fig. 3. Signature verification module

position information, working information), etc. The monitoring information table is an important information of the signature verification module. It is obtained through the exchange board information of the communication management machine, and then through encryption and decryption. It is generally in PDF, WORD, and EXCEL formats. The data generated from the substation end is transmitted to the remote control motor through the router, so that it has the automatic identification function and ensures the reliable transmission of information.

The information of the signature verification module is basically stored in the signature information table, and the data is sent to the signature system through the router.

3.3 Check Network Dispatching Module

The substation remote machine information check control system used is used in the power information intranet. Figure 4 shows the check network dispatching module structure.

The network automation team is configured in the master station machine room. The leaders of substation operation, monitoring acceptance, automation and dispatching use the power information network to access and use this system. The network of the supervision leadership office can realize centralized management of system monitoring point information. The system is put into use as the information of the substation monitoring point, and the automatic check control system is isolated and dispatched by using the horizontal isolation device. The network automation team completes the change confirmation of the monitoring points of the horizontal isolation network, uses an image server to complete the mapping of data in this network, and corrects abnormal data through the management of monitoring information.

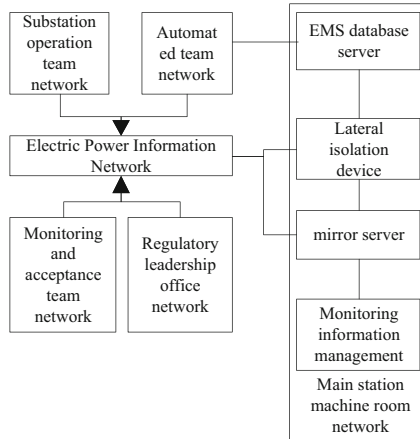

Fig. 4. Check network scheduling module

4 System Software Design

Computer vision is an interdisciplinary field, which focuses on extracting advanced information from images through computers, and seeks to automate tasks completed by human vision systems.

4.1 Information Identification Based on Computer Vision

The verification network scheduling module is an important component of the substation remote control information verification control system. It is mainly responsible for verifying and scheduling the remote motor information, ensuring the accuracy and consistency of the remote motor status, parameters, and indicator lights in the substation.

In the verification network scheduling module, it is first necessary to establish a verification rule library that contains various standards and requirements for remote machine information. These rules can be defined based on national standards, industry norms, and the requirements of the substation itself. The verification rule library can include the legal range of values for the state of the remote machine, the correctness of parameter settings, the on/off state of the indicator light, and so on.

Next, in the verification network scheduling module, computer vision technology will be used to automatically identify and analyze the remote machine information on the substation equipment. Through image processing and pattern recognition algorithms, information such as the status, parameters, and indicator lights of the remote motor can be extracted and compared with the verification rule library.

The verification network scheduling module can also achieve real-time monitoring and alarm functions for remote machine information. Once it is found that the remote machine information is inconsistent with the standards in the verification rule library or there are abnormal situations, the system will promptly issue an alarm to remind the operator to pay attention and take corresponding processing measures.

In addition, the verification network scheduling module can also record and store verification results, and generate corresponding reports and statistical information. These data can be used for analyzing and evaluating the operational status of equipment, helping to optimize the operation and maintenance management of substations, and providing support for decision-making.

In order to accurately identify the normal and abnormal information of substation remote motor, the information target of substation remote motor must be highlighted as much as possible. And computer vision technology can identify substation remote motor information with high accuracy and consistency, without being affected by human subjective factors. It can also record and analyze the identification results, generate detailed reports and statistical information. Overall, the application of computer vision technology to identify substation remote control information can improve work efficiency, reduce errors, improve system reliability, and provide more data support and decision-making basis for the operation and management of substations.

In the process of information processing, it is necessary to process the grayscale of the color image of the remote motor of the substation. The collected image is RGB color space image, and the RGB value is between 0 and 255. The so-called "grayscale" is to convert RGB images into black and white images. Since the obtained image is an 8-bit grayscale image, it is very different from a pure black and white image. Its grayscale index has 256 levels. Therefore, the grayscale value is also expressed as the brightness value: 0 is the darkest and 255 is the lightest. The pixel value in the original image is converted into the grayscale space grayscale parameter by the weighted method, and the formula is:

$$\varepsilon_i = r \times R_i + g \times G_i + b \times B_i \quad (1)$$

In formula (1), r, g, b Respectively represents the parameter values of red, green and blue colors converted into gray; R_i, G_i, B_i Respectively represent the i the coordinate pixel values in the three figures. Through this function, the image can be converted from a color image to a gray image. The transmission line is prominent after graying, and can be used as the correct input data for subsequent edge gradient fitting.

In the process of image processing, the gradient obtained is different from the edge fitting gradient. The gradient reflects the change of image pixels. Assuming that the image to be processed only contains 0 and 1 pixels, where 0 is the background and 1 is the line edge, fit the pixel with 1 pixel into a straight line, and calculate the slope after fitting, that is, the gradient. The slope after fitting is as follows:

$$\lambda = \tan^{-1} \frac{I_y}{I_x} \quad (2)$$

In formula (2), I_x, I_y Represent the horizontal and vertical coordinates of the pixel points of the fitting point respectively.

The calculation result of formula (2) is the basis for judging the normal information and abnormal information of the substation remote motor. When $\lambda > 1$ It means that the image collected by the remote motor of the substation is white pixels, that is, the information collected in this case is normal information; When $0 < \lambda \leq 1$ It means that the image collected by the remote motor of the substation is black pixel, that is, the information collected in this case is abnormal information.

4.2 Encryption and Decryption Before Verification Information Table

Because encryption technology is a relatively safe way for data transmission in the network, this kind of security defense measure that users can control is particularly popular in the power system, that is, it can provide comprehensive security protection for important information at a low cost. In the field of encryption technology, the data type that is encoded and protected after the original data (i.e. plaintext) is encrypted by the encryption device (hardware, software) and the key (public key or private key) is called ciphertext. The method of recovering the ciphertext to the original plaintext by decryption is called decryption, which is the reverse processing of encryption, as shown in Fig. 5.

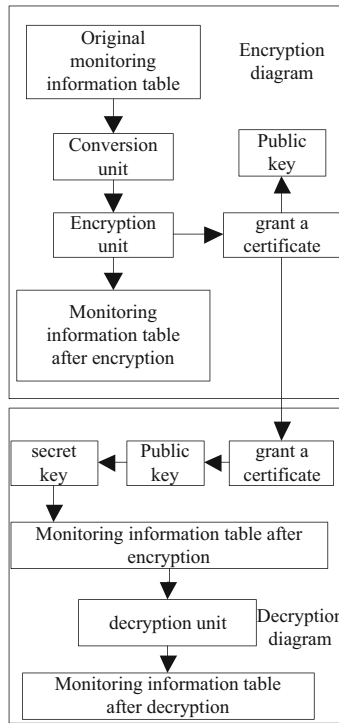

Fig. 5. Encryption and decryption in front of the check information table

Due to the importance of the monitoring information table, in this system, especially before sending the monitoring information table, encryption measures are taken for the sent monitoring information table, and then the received monitoring information table is decrypted. AES algorithm is used for encryption. In the AES algorithm, the byte replacement operation of the S-box is mainly completed by the S-box. The S-box of AES is a structure of inverse multiplication transformation, which is the only nonlinear transformation method. After the inverse multiplication transformation of the S-box, the

results are as follows:

$$S[c] = h(\alpha(c)) \quad (3)$$

In formula (3), h Indicates affine operation; α Represents the multiplication inverse operation; c Indicates clear text. The implementation of S-box is to decompose the elements of a large area into elements of a small area, and then carry out the multiplication inverse operation in the large area after a series of square, multiplication and other operations. In combination with formula (3), the inverse multiplication operation is transformed, and the transformation result is:

$$S^{-1}[c] = h^{-1}(\alpha^{-1}(c)) \quad (4)$$

In formula (4), h^{-1} Represents an affine transformation.

Combining formula (3) with formula (4), we can get the results of inverse S-box multiplication and inverse multiplication, thus realizing S-box transformation in AES algorithm. With the support of S-box transformation structure, row displacement processing adopts a method based on multiplication, addition and matrix multiplication, and each column of data is regarded as a polynomial in a finite area. In the algorithm process, plaintext is byte based, and the corresponding components rearrange the bytes in the register to achieve line displacement under the S-box transformation structure.

For the column mixing operation, the data is multiplied by the same multiplication coefficient. The row mixing operation is completed by increasing and looping, and is saved in the register. When the calculation is completed, its output value will be transmitted to the serial and conversion device, which effectively ensures the security of data transmission and achieves the purpose of preventing selected ciphertext attacks. The above principles and methods are used for encryption and decryption. The original monitoring information table (clear text) is converted into the format required by the user through the conversion unit, and encrypted through the encryption unit. The encrypted key is obtained by the user by issuing a certificate. The encrypted ciphertext is sent and decrypted into its reverse.

4.3 Information Verification Process Design

The movement machine information verification process is realized through the simulation system of the dispatching master station, as shown below:

Step 1: Realize the configuration of the movement forwarding table and communication channel, create a verification platform according to the simulation system of the dispatching master station, and detect the channel conditions, alarm information and movement information.

Step 2: simulate the dispatching master station, receive the telemetry value of the moving device, and use it in the manual point-to-point and multi-point testing of the moving device;

Step 3: Real time monitoring, archiving, recording, analysis and comparison of communication messages to automatically detect the correspondence between the output of the station end and the response of the master station, so as to effectively achieve information closed-loop management.

Step 4: display the wrong message classification, analyze the fault tolerance of code missing, realize the diagnosis and analysis of message and data exceptions, and realize fault location and traceability. According to the abnormal information diagnosis process, the best threshold is selected to determine the best clustering result. The larger the optimal threshold, the higher the accuracy of bad data identification, the more information clusters, and the greater the possibility of miscalculation; On the contrary, the smaller the optimal threshold, the lower the accuracy of bad data identification, the fewer the number of information clusters, and the smaller the possibility of miscalculation. Under the condition of ensuring both diagnostic accuracy and stable clustering, the best threshold is fully considered to determine the change rate of clustering number:

$$P_j = \frac{n_j - n_{j+1}}{\delta_j - \delta_{j+1}} \quad (5)$$

In formula (5), j Represents the number of clusters; n_j, n_{j+1} Respectively represent the j times and times $j+1$ the number of sub cluster data; δ_j, δ_{j+1} Respectively represent the j times and times $j+1$ Secondary clustering threshold. Based on this situation, set the information diagnostic criteria as follows:

$$\begin{cases} \delta = \max(\delta_j) \\ P_j = \min(P_j) \end{cases} \quad (6)$$

According to the identification criteria j Sub cluster threshold δ_j Is the optimal threshold. Under this threshold, the information transmission process has high identification accuracy and stable clustering effect.

Step 5: In order to improve the accuracy of verification, mask technology is used. It is a very effective method to protect the encryption system from attacks. It uses randomly generated numbers (masks) to mask sensitive data. Since this operation is completed based on mask data, sensitive data will not be easily disclosed. In mask compensation, because of the direct exposure of mask parameters, it is vulnerable to energy shocks. The mask compensation operation first calculates the middle value of a mixed output mask type. In addition to the tail wheel, it can be described by the following formula:

$$\mu(Ma) = E(\phi(\vartheta(Ma))) \quad (7)$$

In formula (7), E Represents a mask group; ϕ Represents the middle value of the mask; $\vartheta(Ma)$ indicates the replacement mask value. On this basis, using the design idea of the algorithm, the mask value needed for the next round is obtained. In each mask value, the median value of the updated mask type is corrected by the middle value of the previous mask:

$$\phi' = \mu(Ma) \oplus Ma \quad (8)$$

The compensation calculation methods for masks are different for different rounds. In the first round of mask compensation algorithm, the middle value of the mask type obtained by column mixing operation will be generated on this basis. This method can effectively avoid the danger of leakage of the median value of the mixed input mask type in the first round or its Hamming distance, thus enhancing the anti attack capability of the side channel.

Step 6: Automatically record the verification process, save the modification record, and generate a verification report.

5 Performance Test and Analysis

In order to verify the feasibility of the computer vision based information check and control system for substation remote motor, the following tests are designed.

5.1 Verification Data Flow Design

The intelligent station describes the model, instance configuration, communication parameters and signal contact information (such as GOOSE connection) of all IEDs in the station through the SCD file. Each IED completes the real-time exchange of monitoring information with each station control layer equipment (including telecontrol device) by mapping to the manufacturing message specification. Dispatching automation information acquisition is the basis of power grid monitoring and operation, which mainly needs to go through the three-level equipment of information acquisition unit, telecontrol device and dispatching master station. The acquisition unit is responsible for collecting remote signaling, telemetry and other information in the station, and sending it to the background, telecontrol devices and other station control layer equipment. The telecontrol device collects the information sent by each acquisition unit and forwards it to the dispatching master station. The relationship is shown in Fig. 6.

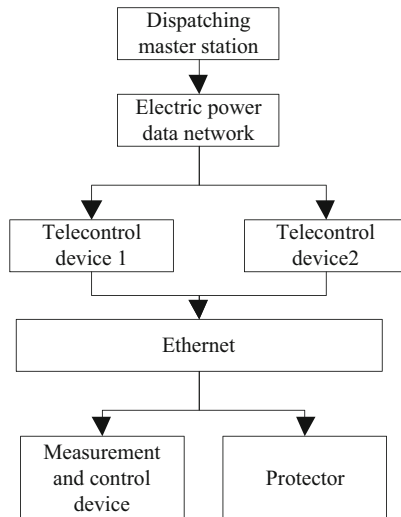

Fig. 6. Data Flow Diagram of Substation Remote Motor

Under the technical system of intelligent substation, the telecontrol device collects the information message of interval measurement and control device, protection device, etc. with MMS message, and the master station receives the data uploaded by the telecontrol device in 104 protocol message format, realizing four general functions of remote signaling, remote control, telemetry and remote regulation. Usually, there are tens of thousands of information in the intelligent station, and the main station business does

not need all of them. The designer will select one or several information in the station and merge them one to one or more to one to form a regulation information point, which will be identified by the address of the unique master station information object (generally natural number). All regulation information points will be summarized to form a regulation information table of the whole station. The regulation information table specifies the information to be transmitted to the master station by the telecontrol device and its corresponding number. Table 1 shows the main contents of the regulation information table. For the convenience of subsequent discussion, the station information code is assigned to each SCD information.

Table 1. Contents of regulation information table and corresponding station information

Information address	Describe	In station index name	Information Code
35	5011 switch control circuit	CB5011 .A1m1	W
36	Phase A closing position of switch 5011 of Shuanglan Line	CB5011 .A1m2	D
37	Phase A closed position of switch 5011 of Shuanglan Line	CB5011 .A1m3	C
38	SF6 pressure is low	CB5011 .A1m4	A
39	High SF6 pressure	CB5011 .A1m5	S
40	The switch is pressed without timeout	CB5011 .A1m6	H
41	Switch pressurization timeout	CB5011 .A1m7	K

Technicians need to complete the configuration of telecontrol devices to form the corresponding relationship between the information index name in the station and the address of the information object in the master station. During operation, the telecontrol device receives and analyzes the action information in the station. Once the information corresponds to the configured index name, the action information to the dispatching master station is generated, and 104 protocol message is used to inform the master station of the action of the corresponding control information point, with SOE time attached.

5.2 Conversion Results of Telecontrol Configuration

According to the flow direction of automation information, the time stamp of action signal is formed by the process layer or bay layer device according to the acquisition time in the signal acquisition link to reflect the signal occurrence time. The time information is identified and recorded in the telecontrol device, and transmitted to the master station together with the signal point in 104 protocol (SOE mode).

On this basis, the idea of multi attribute evidence theory in fault tolerance processing is used for reference to change the singleness of judgment quantity in work, and the correlation between attributes is artificially established and used for subsequent judgment. That is, the SOE time information bit is used to synchronously transmit the address of the control information point to the master station, so as to help the master station personnel judge whether the telecontrol device has performed the correct forwarding. The specific scheme is as follows:

Use simulation equipment (such as MMS communication simulation software, etc.) to send MMS communication message of information action in a station. Part of time data in SOE time scale in the message is forced to be consistent with the information address of the corresponding control information point. Then, after the correct forwarding of the telecontrol device, the data corresponding to the second and millisecond bits of the SOE time of the information received by the dispatching master station should be consistent with the information address of the master station. In case of inconsistency, it can be judged as the remote control device conversion error, as shown in Fig. 7.

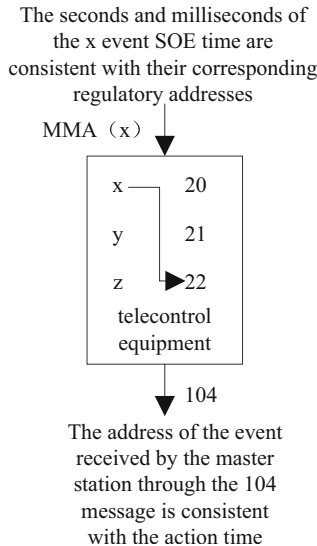

Fig. 7. Results of correct conversion

As shown in Fig. 7, in the regulation information table in the left box, the x information in the station corresponds to the information address of No. 22 of the master station. Send the x event action signal through the simulation equipment. If the project configuration is correct, the telecontrol device will judge that the information corresponds to the regulation information point of the telecontrol master station with address 22 after receiving the message, and send the “22 event” information to the master station with 104 protocol message. If the project configuration is wrong, the x event is mapped to the information addresses 20 and 21, and the telecontrol device will send the message “20 and 21 event occurs”.

In actual work, the simulation equipment can successively send out all the action information in the station to be checked in the order of 104 address number, and the master station side will record all the action information sent by the telecontrol device. This process only takes tens of minutes if one information point is counted every half second. Next, the master station personnel only need to observe that the SOE time data of the received action information is consistent with the address of the information object, and the number of action information and the address distribution of the information object are consistent with the expectation to judge whether the conversion of the telecontrol device is correct. If the software is used for automatic judgment, it can be completed instantaneously.

5.3 Test Results and Analysis

Use end-to-end verification methods, secondary equipment model verification methods, and computer vision based verification methods to compare and analyze the remote conversion results, and compare them with Fig. 7 to verify the accuracy of information verification. If the configuration results are reasonable, the information verification is effective, otherwise it is invalid. The comparison results of the three methods are shown in Fig. 8.

It can be seen from Fig. 8 that the configuration results of the end-to-end verification method and the secondary equipment model verification method are unreasonable, and the information obtained is invalid, indicating that the verification control effect is poor. The use of computer vision based verification methods results in reasonable configuration, correct information verification, and effective information obtained indicates that the verification control effect is good.

The seconds and milliseconds of the x event SOE time are consistent with their corresponding regulatory addresses

MMA (x)

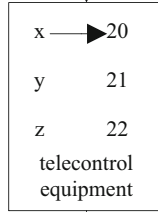

104

The address of the event received by the master station through the 104 message is inconsistent with the action time

(a) End to end verification method

The seconds and milliseconds of the x event SOE time are consistent with their corresponding regulatory addresses

MMA (x)

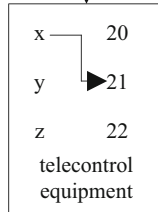

104

The address of the event received by the master station through the 104 message is inconsistent with the action time

(b) Verification method of secondary equipment model

Fig. 8. Comparison and analysis of verification results of three methods

The seconds and milliseconds of the x event SOE time are consistent with their corresponding regulatory addresses

MMA (x)

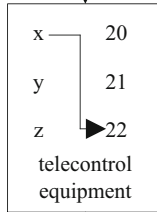

The address of the event received by the master station through the 104 message is consistent with the action time

(c) Verification method based on computer vision

Fig. 8. (continued)

6 Conclusion

This article designs a computer vision based substation remote motor information verification and control system. The system consists of a verification view module, a verification signature module, and a verification network scheduling module, forming the hardware environment of the system. Based on this, computer vision technology is used to identify the remote motor information of the substation. After encryption and decryption processing, closed-loop management and clustering processing are used to achieve the verification process of the information.

Despite achieving certain results in this study, there are still some challenges and room for improvement. For example, the robustness of the system in complex environments still needs to be further improved.

In summary, the computer vision based substation remote machine information verification and control system provides an innovative solution for substation operation and maintenance. We believe that in future development, this system will be further improved and promoted, and will bring greater convenience and benefits to the operation and management of substations.

References

1. Nassu, B.T., Marchesi, B., Wagner, R., et al.: A computer vision system for monitoring disconnect switches in distribution substations. *IEEE Trans. Power Deliv.* **37**(2), 833–841 (2021)

2. Li, Y.S., Gao, B., Xu, L., et al.: An anomaly detection method for digital substation abnormal data based on fusion of difference sequence variance and CPS. *Power Syst. Clean Energy* **37**(02), 30–41 (2021)
3. Zhang, K.X., Tan, L., Xu, M.H., et al.: Research on intelligent substation simulation modelling technology based on data acquisition technology. *IOP Conf. Ser. Earth Environ. Sci.* **55**(9), 5206–5210 (2020)
4. Wang, Z.H., Tu, Y.X., Wang, H.Y., et al.: Interactive data monitoring method of substation regulation based on full communication link. *J. Nanjing Univ. Sci. Technol.* **46**(04), 451–459 (2022)
5. Yan, M.Q., Yang, Y.J., Zhao, F.: A data stream anomaly detection method based on an improved OCSVM smart substation. *Power Syst. Protect. Control* **50**(06), 100–106 (2022)
6. Jin, X.B., Zheng, W.Z., Kong, J.L., et al.: Deep-learning forecasting method for electric power load via attention-based encoder-decoder with Bayesian optimization. *Energies* **14**(6), 1596–1603 (2021)
7. Raveendran, S., Chandrasekhar, A.: Inspecting and classifying physical failures in MEMS substrates during fabrication using computer vision. *Microelectron. Eng.* **254**, 111–116 (2022)
8. Zeng, Y.X., Su, W., et al.: Power data storage and sharing method based on blockchain and data lake. *Electr. Power Eng. Technol.* **41**(03), 48–54 (2022)
9. Jimenez, V.A., Will, A.: A new data-driven method based on Niching genetic algorithms for phase and substation identification. *Electr. Power Syst. Res.* **35**(10), 199–209 (2021)