



# Using HTC Vive to Design a Virtual Reality Simulation Environment on Radiography

Lun-Ping Hung<sup>1</sup>, Mine-Che Wu<sup>2</sup>, Yu-Rang Jhang<sup>3</sup>, and Wen-Lung Tsai<sup>3</sup>(✉)

<sup>1</sup> Department of Information Management, National Taipei University of Nursing and Health Sciences, Taipei 112, Taiwan

<sup>2</sup> Radiation Oncology Division, Far-Eastern Memorial Hospital, New Taipei 220, Taiwan

<sup>3</sup> Department of Information Management, Asia Eastern University of Science and Technology, New Taipei 220, Taiwan

wltsai@mail.aeust.edu.tw

**Abstract.** This study aims to design and develop a virtual reality situational simulation system for the radiation oncology unit in a hospital. This study applies HTC Vive, Autodesk 3ds Max and Unity 3D to develop a virtual reality simulation model, followed by programming in the C# language and Visual Studio compiler to create a virtual scene for the stereotactic radiography imaging verification process. The result of this study provides a prototype system.

**Keywords:** radiography · virtual reality · HTC Vive · simulation system

## 1 Introduction

In recent years, using virtual reality (VR) related technologies in various industries, particularly the medical, healthcare, and education sectors, has become increasingly popular. Integrating information and smart technologies in teaching and training can address additional challenges faced by traditional methods.

Featuring interactivity and real-time response, VR allows users to freely operate the computer and view the completed design from any angle and position [1]. VR technology has shown great promise in the research and development, training, and education of medical physiology, gastrointestinal endoscopy simulators, clinical anatomy simulators, among other applications. In addition, it is widely used in the field of medical imaging. According to foreign studies, VR simulation featuring dynamic interaction and feedback can help students in related medical imaging degrees cultivate their clinical skills.

By creating a scenario similar to the actual clinical situation, simulation teaching allows students to continuously practice skills in the virtual clinical scene, while the clinical supervisor observes their execution process and provides feedback [2]. In radiography, the integration of VR with the cultivation of radiography talents to perform online and offline theoretical and practical courses have the advantages of both high efficiency and convenience.

## 2 Literature Reviews

In recent years, VR-related technologies have matured, with various VR products developed by different industries in response to the introduction of VR technology. VR refers to an emerging computer technology that combines multimedia and simulation techniques to create a virtual environment that integrates auditory, visual, and other senses, allowing users to be immersed and interact with it [3].

VR refers to the “simulation of reality.” VR primarily uses real-time 3D rendering to present immediate, dynamic, and interactive scenes to shorten the gap in the user’s cognition. When assisted by appropriate software and hardware human-machine interfaces, it allows users to interact with the virtual simulation and, as a result, increases their interest and learning effectiveness [4]. VR devices provide users with immersive experiences in three-dimensional virtual scenes. The most famous VR headsets at present include Oculus Rift, 3Glasses, HTC Vive, and PlayStation VR, with the HTC Vive being the most popular [5].

The HTC Vive is currently one of the most popular VR headsets. Through the “room-scale” technology, HTC Vive converts a room into a three-dimensional space using a locator, allowing users to navigate and move around naturally in the virtual world. In addition, the device allows users to dynamically manipulate objects using motion-tracked handheld controllers, providing a sophisticated interactive, communicative, and immersive experience [6]. This study uses HTC Vive as the VR hardware and combines it with auditory and visual VR technologies to provide users with a good VR experience. The visual part uses interactive question-and-answer and the operation simulation of virtual objects, whereas the auditory part incorporates objects related to the virtual ones. The combination of the two will bring a realistic virtual interactive experience.

Image-guided radiation therapy (IGRT) uses advanced imaging technology to better define the tumor target and is critical in reducing and ultimately eliminating uncertainties. [7] Currently, most radiologic technology programs teach students positioning and radiation dose techniques in a traditional X-ray laboratory. Virtual simulation provides a safe and convenient learning environment where students can practice techniques without the risk of irradiating patients. Instructors can foster deep learning in virtual simulation laboratory environments by designing the software around specific course outcomes (e.g., cognitive and psychomotor skills) and engaging in sound educational strategies and theory [8].

## 3 Method and System Design

This study aims to develop a VR-based system that can address the challenges and issues of existing training programs for radiography interns and staff. It is expected that this system can improve the professional ability of users and, as a result, increase radiography accuracy. In terms of system simulation, this study will first use Autodesk 3ds Max and Unity 3D to develop a VR simulation model, followed by programming in the C# language and Visual Studio compiler to create a virtual scene for the stereotactic radiography imaging verification process.

Figure 1 is the system architecture in this study. The VR terminal device (HTC Vive), shown on the right of the figure, communicates with Unity at the hardware layer together

with Open VR API and Steam VR API. The system is supplemented with specific exoskeleton data and object configurations to create a complete set of VR interactive experiences after compilation by Unity.

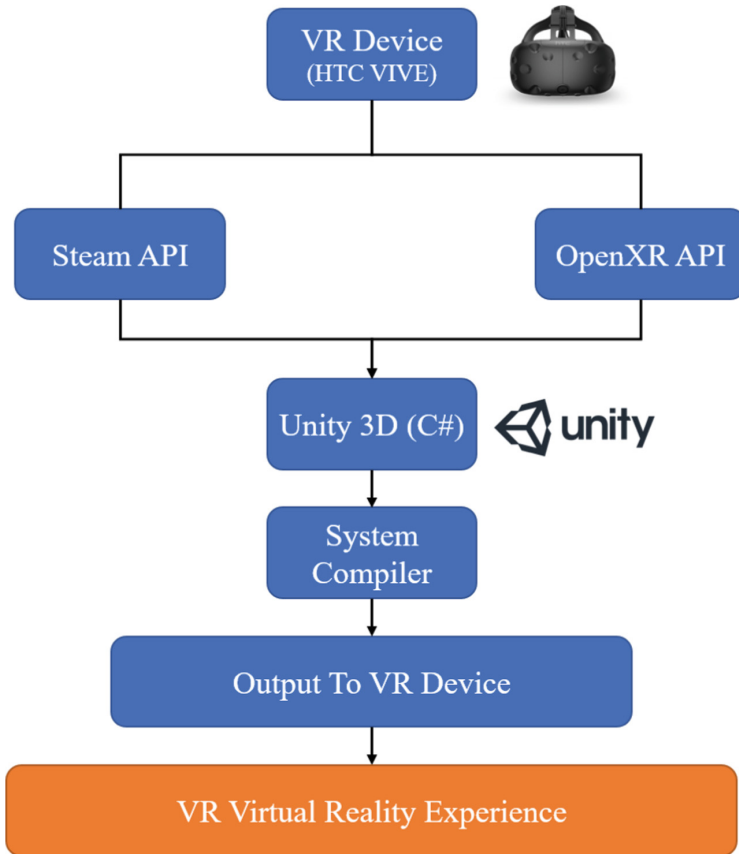

**Fig. 1.** System Architecture

This study sequentially models the pre-planned simulation scenes before importing the completed model into Unity. Considering compatibility issues, the attributes of the shader are set independently in Unity. The light source is subsequently adjusted to make the scene more realistic. Once the scene is constructed, the VR device is connected to Unity through the API. After the compilation is executed, the API will immediately judge and process the tracking information of the locator, output it as an image through operations in Unity, and send it back to the helmet to achieve the final visual feedback effects (Fig. 2).

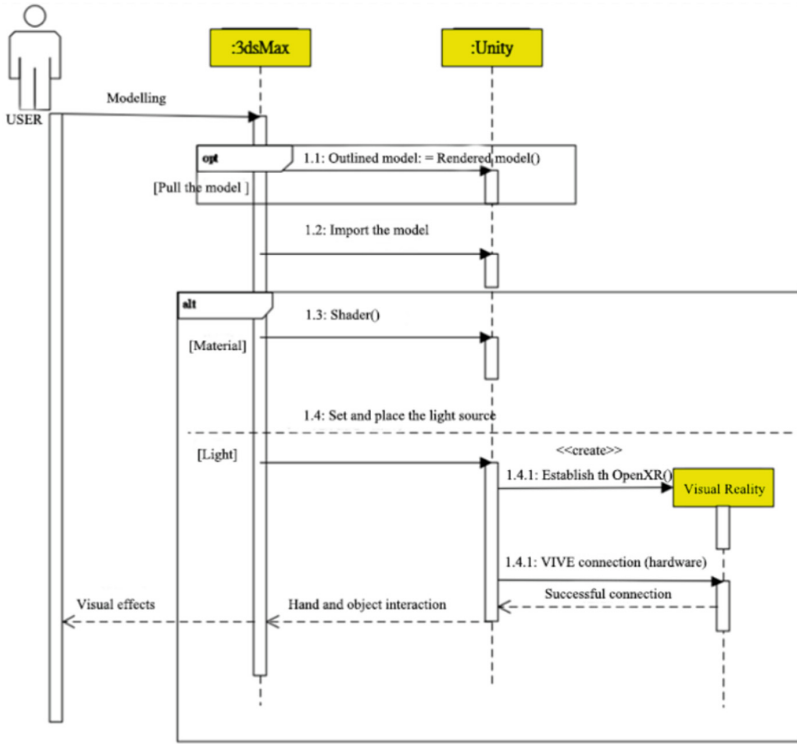

Fig. 2. System Sequence

### 4 Conclusion and Future Works

Currently, this study only presents preliminary system design and the prototype as Fig. 3 and Fig. 4. In the near future, this study will be used to develop a complete VR radiography simulation system. The application of VR technologies in the medical care industry is gaining popularity. In addition to overcoming the inconveniences of traditional healthcare practice and education, it is capable of significantly improving the working methods and execution efficiency of healthcare in the future. However, some technical challenges remain, including integration of medical and nursing information systems, clarity and resolution of screen presentation, accuracy of interaction, and durability of hardware equipment. Although numerous software-related and hardware-related technical problems need to be addressed, applications of VR in the medical field have bright future prospects.

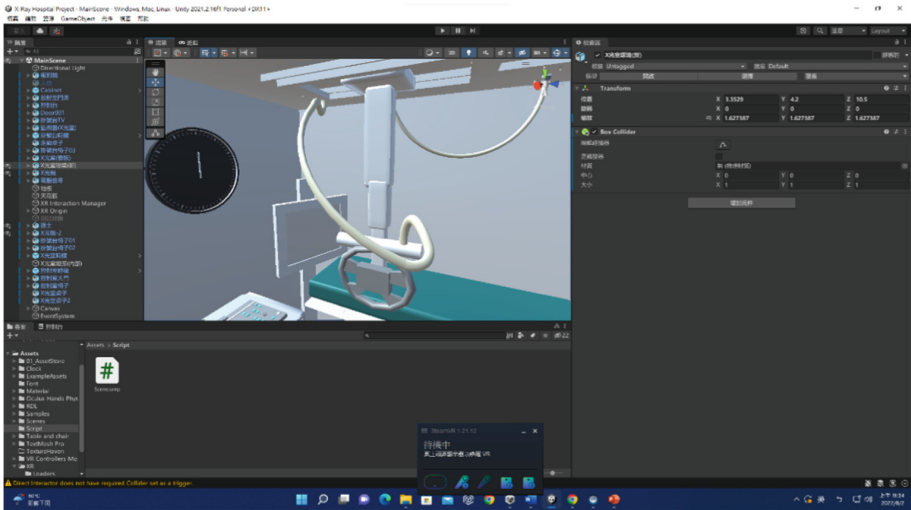

Fig. 3. Screenshot of X-Ray Machine

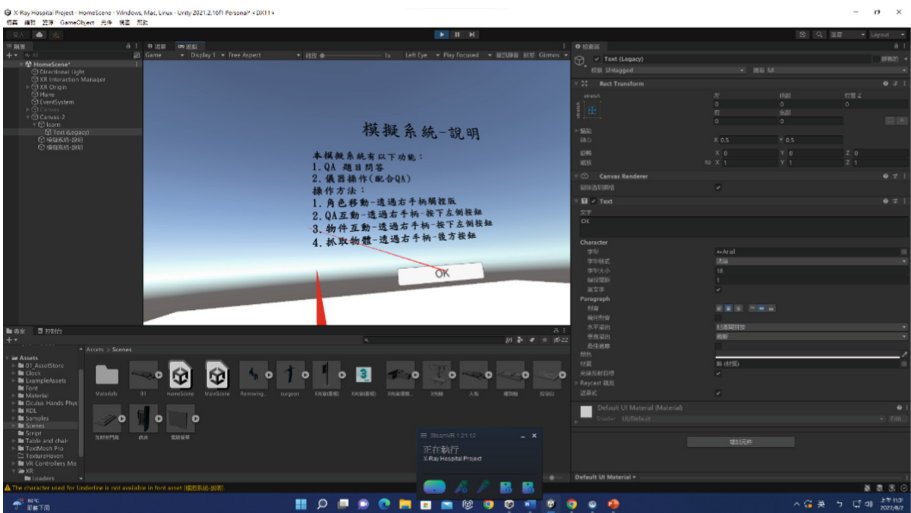

Fig. 4. Screenshot of System Instructions

## References

1. Li, Z., Kiiveri, M., Rantala, J., Raisamo, R.: Evaluation of haptic virtual reality user interfaces for medical marking on 3D models. *Int. J. Hum. Comput. Stud.* **147**, 102561 (2021)
2. Lei, Y.Y., Zhu, L., Sa, Y.T.R., Cui, X.S.: Effects of high-fidelity simulation teaching on nursing students' knowledge, professional skills and clinical ability: a meta-analysis and systematic review. *Nurse Educ. Pract.* **60**, 103306 (2022)

3. Wu, Y., Liu, J.: Research on college gymnastics teaching model based on multimedia image and image texture feature analysis. *Discov. Internet Things* **1**(1), 1–13 (2021). <https://doi.org/10.1007/s43926-021-00015-6>
4. Sung, B., Mergelsberg, E., Teah, M., D’Silva, B., Phau, I.: The effectiveness of a marketing virtual reality learning simulation: a quantitative survey with psychophysiological measures. *Br. J. Edu. Technol.* **52**(1), 196–213 (2021)
5. Borglund, F., Young, M., Eriksson, J., Rasmussen, A.: Feedback from HTC vive sensors results in transient performance enhancements on a juggling task in virtual reality. *Sensors* **21**(9), 2966 (2021)
6. Wang, Y., Grant, S., Grist, M.: Enhancing the learning of multi-level undergraduate Chinese language with a 3D immersive experience-an exploratory study. *Comput. Assist. Lang. Learn.* **34**(1–2), 114–132 (2021)
7. Chamunyonga, C., Rutledge, P., Caldwell, P.J., Burbery, J.: The implementation of MOSAIQ-based image-guided radiation therapy image matching within radiation therapy education. *J. Med. Radiat. Sci.* **68**(1), 86–90 (2021)
8. Little, J.: Using virtual simulation to increase deep learning in radiography students. *Radiol. Technol.* **92**(4), 324–330 (2021)