



The Device of Graphite Washed off Acid-Base Automatically Based on MCU

Huang Yaoqun^(✉), Zhou Bo, Wu Yan, and Zhang Haijiao

School of Electronics and Information Engineering, Heilongjiang University of Science and Technology, Harbin 150022, China
huangyaoqun@126.com

Abstract. Graphite water elution acid and alkali is the indispensable key link of producing high purity graphite, expanded graphite and other graphite deep processing. This design adopts the AT89S52 single chip microcomputer as the control core, supplemented by pH sensors, temperature sensors, power amplification circuit, display circuit, buttons, and control circuit, controlling the water pump, motor, scraper centrifuge, air knife and mechanical device to achieve the automation of graphite automatic washing to take off the acid and alkali, solving the problems such as using artificial detection graphite liquid pH to test whether it can achieve specific standard, causing inaccurate measurement, inefficiency and waste of human resources and other issue. Through the application of the graphite automatic water elution acid-base device, it can significantly improve graphite washing steps in the process of deep processing of efficiency and effectiveness, shortening the process time, reducing the labor costs and electricity consumption. The results show than compared with the conventional similar equipment this design can reduce the electricity consumption nearly 35% and improve work efficiency about 2.5 times, have a high practical application value of engineering.

Keywords: Graphite washed · Automation · pH sensor

1 Overview

At present, washing the centrifugal equipment at home and abroad can only be washed after the material by means of centrifugal dry, and do not have the function of the pH detection for the washing material. Each wash must be manually sampled on the lotion. PH meter is used to measure the discharge of the pH of the water. And then it is judged whether to mark, if not up to standard, it requires manpower and the material to water, centrifugal, repeat the above steps, which is time-consuming. If washing time is not long enough, it will make drainage pH value not standard, which needs to adjust the time of centrifugal, a new water centrifugal. If washing time is too long, it is a waste of time, and the efficiency is low. The equipment can be concluded a kind of material washing process after many washing experiments, which both increased the burden of human, and operation is extremely complicated [1, 2].

This design mainly adopts intelligent real-time monitoring measures, which will make washing machine and washing centrifuge become one, achieving automatic control of the equipment by adding a pH sensor and temperature sensor. When washing, electrical machine inside the washing machine can turn positive and negative two directions in turn, mixing fully to material, which will make part of the glue material conduct a thorough break by washing machine's first wash, preventing incomplete washing of materials' getting together in the process of washing materials. After washing, materials through a water pump will be broken and lotion with import water washing in the centrifuge, the centrifugal dehydration, and set a pH sensor and a temperature sensor in the outlet of the centrifuge, collecting the information of lotion's PH in time when washing centrifuge dehydration. Then to judge whether the PH of lotion is standard through the single chip microcomputer. If it is not up to standard, washing centrifuge will continue to run until the PH of lotion is up to standard, it will stop working automatically and then the single-chip microcomputer control water centrifuge spatula to scrape down in the material [3], and is accompanied by the end of the prompt, suggesting it is the end of the washing. It not only can solve common equipment which can not be real-time monitoring of pH value and achieve full automatic difficulty, and also can lighten the burden of human, save water resources.

2 System Design Scheme and the Key Circuit

This design system regards AT89S52 single chip microcomputer as the control core of the system. Circuit is controlled by button, PH value detection and power amplifier circuit, A/D conversion circuit, temperature compensation circuit and the water level sensor circuit, etc. and pH sensors, temperature sensors and water pumps, pneumatic scraper centrifuge [4], the mechanism structure diagram of system is as shown in Fig. 1.

When system is working, it puts graphite raw material into the washing machine, doing washing mixing. Blades in the washing machine have positive and negative rotation alternately, which can break materials thoroughly, preventing materials glue together because of going bad [5, 6]. After washing mixing water pump will make graphite material in the washing machine and lotion smoke into the centrifuge, and open water and centrifugal centrifuge. Placing a pH sensors at the outlet of the centrifuge, lotion for real-time measurement of discharge outlet, measuring the size of the PH value, transmitting numerical value to single chip microcomputer to judge whether graphite materials washed completely through single chip microcomputer. If the pH value is not up to standard, centrifuge will keep water for material and the status of centrifugal, until single chip microcomputer judges that the pH sensors detect the liquid pH value standard, centrifuge begins to stop work. Then open air knife, sweep the materials on the walls of the centrifuge, complete the automated processing of graphite automatic washing to take off the acid and alkali. This design also chooses LCD to display the current working state, we can intuitively understand the working information of system. At the same time, it can also show washing or centrifuge time. And also it can be adjusted by button scanning circuit of washing or centrifugal time and for other operating systems. When washing is over and through the test, the buzzer will beep, warning that staff's washing ends, reducing the human, improving efficiency.

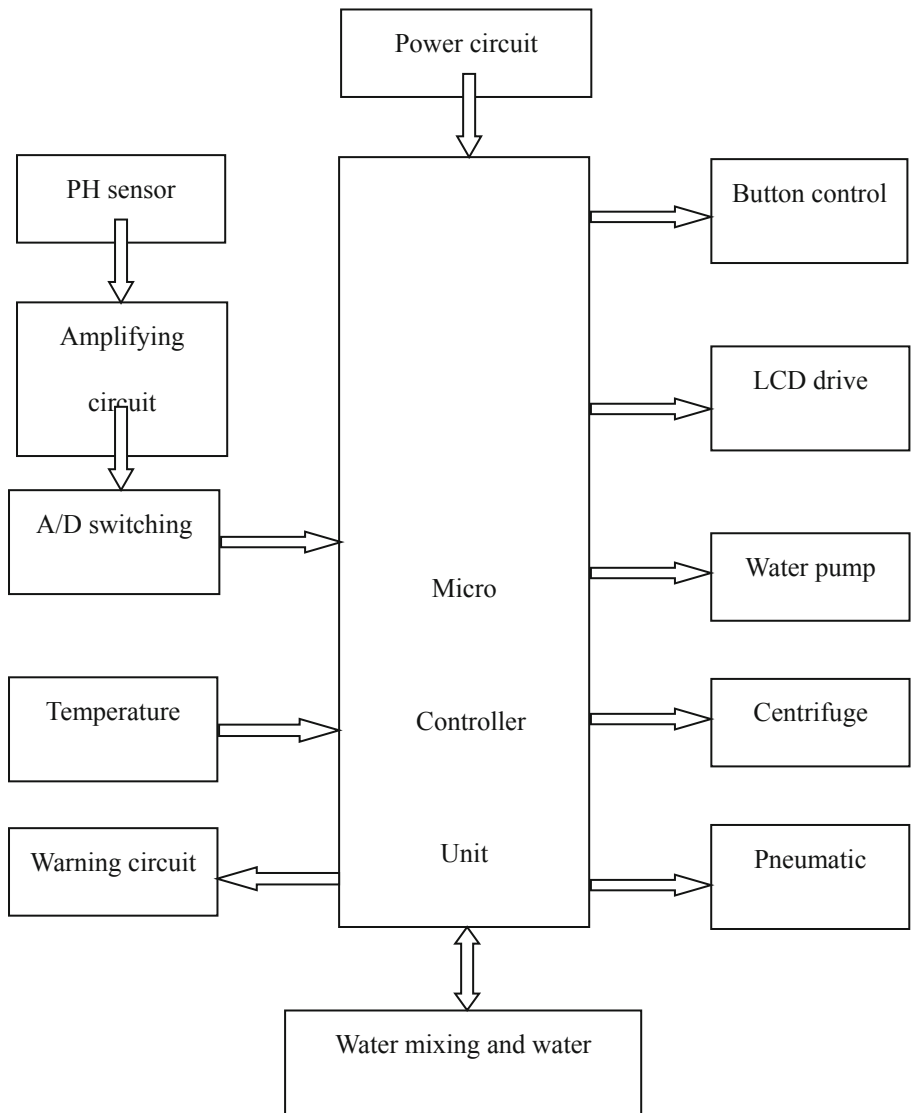

Fig. 1. The structure diagram of material remove waste acid alkaline bath system

This design also chooses LCD to display the current working state, we can intuitively understand the working information of system. At the same time, it can also show washing or centrifuge time. And also it can be adjusted by button scanning circuit of washing or centrifugal time and for other operating systems. When washing is over and through the test, the buzzer will beep, warning that staff's washing ends, reducing the human, improving the process efficiency.

2.1 Button Control Circuit

Button circuit is mainly used for washing time of systems and the setting of graphite lotion PH reference. This design adopts the independent key, key input with low level effectively, when the switch is not pressed, the input for the high level, after closing, input is low level. Connection circuit is shown in Fig. 2.

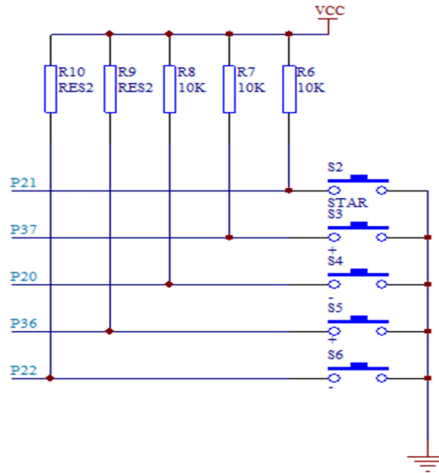

Fig. 2. Button control circuit

2.2 PH Value Detection and Power Amplifier Circuit

PH sensors are used to detect the centrifuge after washing lotion of pH value, to determine the graphite raw water elution the effect of acid and alkali, but as a result of general pH sensor output voltage is in the Howe v level, if it is directly transmitted to MCU and it cannot identify [7], so it is necessary to carry out amplification on its output voltage driving. PH sensor resistance generally in more than 10m euro, ordinary amplifying circuit resistance can never reach. So you need to select input fault of power amplifier, so that you can need not consider to carry out amplification on its pH sensor resistance. This design chooses OP07 power amplifier to achieve as shown in Fig. 3, which has characteristic of low disorders, high open-loop gain especially suitable for high gain measurement equipment and the weak signal amplification. At the same time, it adopted to eliminate the zero wave potentiometer, which can effectively eliminate the zero drift.

2.3 A/D Conversion Circuit Design

PH value detection signal which is zoomed is a an analog voltage signal, needing to convert to digital signals, in order to conducting detection and management. The design adopts TLC1549 as the core of the A/D conversion circuit. It is 10 AD converter, internal converter with high speed (10 μs conversion time), high precision (10 resolution,

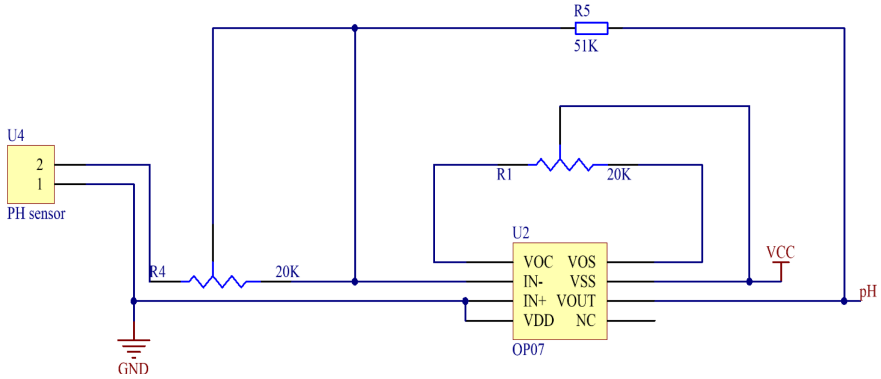

Fig. 3. PH value detection and power amplifier circuit

maximum plus or minus 1 LSB not adjust error) and the characteristics of low noise. TLC1543 chip of the three input and an output terminal with 51 series microcontroller I/O ports can be connected directly.

2.4 Temperature Compensation Circuit Design

This system adopts the pH sensor as washing graphite material detection device, because the change of medium temperature has the influence on the electrode pH measurement, which will lead to the measurement deviation, affect the washing effect. So you need to use temperature compensation correction ways for pH sensor calibration to measure precise pH value. Considering the design needs to measure the temperature of the acid and alkali liquid, so using strong acid and alkali resistance and with industrial waterproof outer packing of the digital thermometer DS18B20, the thermometer provides nine (binary) temperature readings, measuring range from $-55\text{ }^{\circ}\text{C}$ to $+125\text{ }^{\circ}\text{C}$, the incremental value of $0.5\text{ }^{\circ}\text{C}$, is available in 1s (typical) within the temperature transform into digital. At the same time, adopting the mode of external power supply, speeding up the measuring [8].

2.5 Water Level Sensor Circuit Design

Considering the design needs to measure the liquid level of the acid and alkali liquid, so we should choose the sensors which are strong acid and alkali resistance, high temperature resistant, anti-aging, tearing resistance, difficult to produce scale, no water seepage. Therefore, this design uses industrial water level sensor. It adopts special composite material and design pulse of alternating voltage internally, and use high temperature resistant material encapsulation, make the sensing component with super corrosion resistance, anti scaling function, stable work. The core parts of sensor adopt foreign latest win min element has high precision, to ensure the measurement precision in bad environment. Water level sensor is mainly composed of four resistors in series, from the bottom to up, in turn, is 30k, 10k, 10k, 10k, and the corresponding electrode from bottom to top

respectively are: the public, 75% electrode, 60% electrode, 50% electrode, 30% electrode. No water in the tank, the water resistance is 60k, with the increase of water level, the resistance will decrease in turn. When measuring water level, the sensor is inserted into the water, the deeper the resistance is smaller.

3 The Design of System Software

The design of System software in the Windows 7 environment adopts Keil Vision4 software and makes use of C language to write in order to realize the single chip microcomputer control functions. Software control programs include the master control program, the pH reading, button scanning, liquid crystal display subroutine. Master control program controls the overall program. Through their procedure call, the function of each part of the system is realized.

3.1 Main Program Design

After the system is powered on, it begins to initialize. After manual work puts graphite material into washing machine, washing time and PH value of standard setting can be set. After it begins, single-chip microcomputer controls washing machine to wash, which includes the forward and reverse of washing machine. When the washing time ends, it shows washing time's over through the liquid crystal display, accompanied by voice prompt, and then water pump starts to work, which make a mixture of graphite materials and water in the washing machine pump into the centrifuge. At the same time, the centrifugal is opened to do centrifugal dehydration of graphite and to go on washing from the centrifuge internal to the graphite surface water. When washing. PH sensor tests the water solution PH value through real-time monitoring, to determine whether the washing is over or not. If it is not up to standard, washing should be continued. If the PH value of testing standards is up to standard, washing will be over. And then return to the main program and continues to scan button, preparing for the next operation. The system main program flow chart is shown in Fig. 4.

3.2 PH Value Setting Subroutine

When operating procedures are for setting pH, through scanning the buttons, to determine whether the corresponding key is pressed or not, if pressed, then bring up the corresponding subroutine to control system and through the LCD12864 to display. If no press, then continue to scan. S2 for the subsequent operation keys, the S3 key for pH value, minimum value minus 0.1; S4 for pH value, minimum value will be increased by 0.1; S5 for pH value maximum reduced 0.1; A maximum S6 for pH value will be increased by 0.1. PH value set subroutine flow chart shown in Fig. 5.

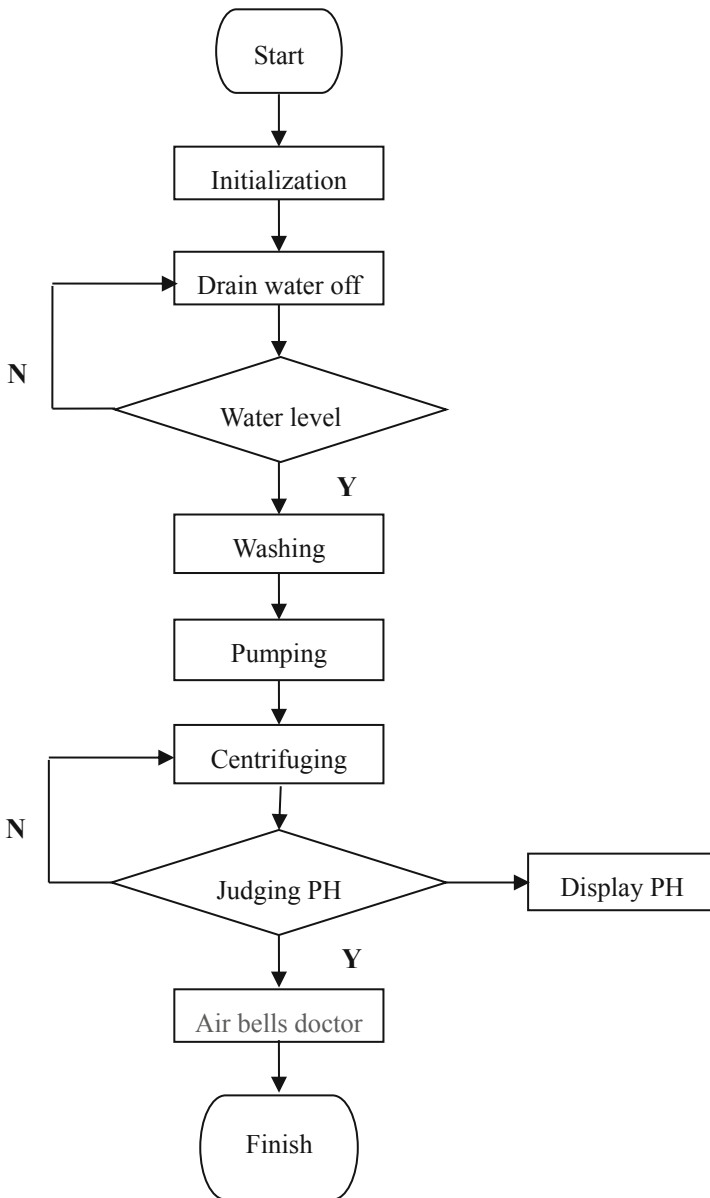

Fig. 4. Main program flow chart

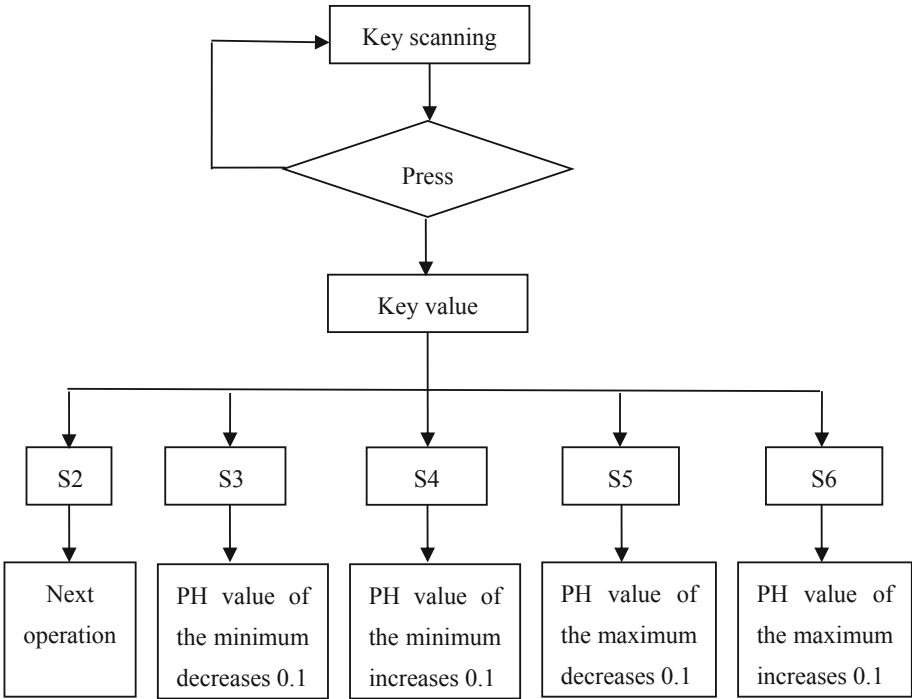

Fig. 5. PH value setting subroutine flow chart

4 Conclusion

The design puts AT89S52 single chip microcomputer as control core, combing with high precision dynamic real-time monitor of the pH value, realizing the full automatic control for the graphite water elution acid-base device. The system hardware structure is compact and simple, which is easy to control, shortening the time of preparation process of high purity graphite and expanded graphite, significantly improving the effect of graphite washed link, improving the production efficiency, solving the traditional process using artificial detection caused by inaccurate measurement, such problems as low efficiency and waste of human resources, reducing the labor costs and electricity consumption. In order to reach the purpose of rapid graphite washing in the industry, compared with the conventional similar centrifuge, the motor power have been increased from 30 kw to 55 kw, the rotate speed have been increased from 970 RPM to 2400 RPM, and realized the PH value automatic accurate measurement and automatic control. The experiment result shows that compared with the traditional similar equipment, the power consumption of this equipment can be reduced nearly 35%, the manual unloading time can be greatly reduced, and the production efficiency can be significantly improved. At the same time, this design can also be applied to other industrial production in the field of material of water washing and processing, which has high value in engineering application and popularization value.

References

1. Baojun, W.: Application of centrifuge in the treatment of pickling wastewater in steel plants. *Chem. Equip. Technol.* **5**, 5 (2017)
2. Qianyun, W.: Influencing factors analysis of dewatering effect of horizontal centrifuge in coal washing plant. *Shandong Ind. Technol.* **20** (2018)
3. Wu wei. The Application of vertical scraper discharging centrifuge. *Min. Equip.* **5** 2018
4. ATMEL Corporation. AT89S52 datasheet. www.atmel.com
5. Lijie, H.: Study on improving the comprehensive efficiency of imported scraper centrifuge. *China Plant Eng.* **10** (2014)
6. Zhenxiang, Z.: The factors affecting the centrifugal efficiency of siphon automatic discharge centrifuge. *Chem. Equip. Technol.* **2** (2014)
7. Wittmer, D.: pH sensor introduction (2015)
8. Dallas Semiconductor: DS18B20 datasheet. www.dalsemi.com