



Application of Iridium Data Communication System in Information Transmission of Ocean Monitoring Buoy

Ye Liu^{1,2,3(✉)} and Yu-zhe Xu^{1,2,3}

¹ Institute of Oceanographic Instrumentation, Qilu University of Technology (Shandong Academy of Sciences), Qingdao, China

ly0822cn@163.com

² Shandong Provincial Key Laboratory of Ocean Environmental Monitoring Technology, Qingdao, China

³ National Engineering and Technological Research Center of Marine Monitoring Equipment, Qingdao, China

Abstract. In view of the problem of poor real-time transmission of the traditional information transmission method of marine monitoring buoy, the transmission speed is slow. Based on this, iridium data communication system is applied to the information transmission of ocean monitoring buoy. Through the establishment of the overall framework of Iridium satellite communication system, determine the buoy information transmission network protocol. On the basis of the network protocol, use Iridium satellite data communication system to obtain the location information of the marine monitoring buoy, and then process the obtained information. Finally, upload the processed buoy information to complete the transmission of the marine monitoring buoy information. Compared with the traditional method of information transmission of ocean monitoring buoy, the experimental results show that the method of information transmission of ocean monitoring buoy using iridium data communication system can complete the transmission of buoy information in a shorter transmission time, with better real-time transmission.

Keywords: Iridium data communication system · Marine monitoring · Buoys · Information transmission

1 Introduction

With the development of operational marine monitoring system, marine monitoring technology is also developing rapidly. China is speeding up the construction and improvement of the marine environment three-dimensional monitoring system covering China's coastal waters. At present, there are many kinds of instruments and sensors used in the marine environment monitoring system, with different working principles and positions. They cover the observation elements from shore to offshore, from air to water, from water to seabed, including dynamic elements, ecological elements and geological parameters [1–3]. The real-time/quasi real-time data acquisition of various automatic monitoring instruments and equipment is the key to ensure the operational

operation of the observation system. The offshore marine monitoring system is far away from the ground, and the conventional cable, short wave, GSM/CDMA and other communication modes are difficult to meet the requirements. At present, the widely used communication mode is all kinds of satellite systems with communication ability [4–7].

Large scale ocean data buoy is a kind of fully automatic and advanced ocean hydrological and meteorological telemetry equipment, which can monitor the ocean hydrological and meteorological parameters of a certain anchor point for a long term, continuous, fixed-point and automatic way, and provide real-time data for the disaster marine environment prediction, ocean development and ocean engineering. It is the main source and important component of the data in the ocean disaster early warning and prediction system [8]. Due to the high requirement of real-time marine monitoring data, the real-time data transmission system of marine data buoy is an important part of the buoy. Since the development of ocean data buoy in China, the real-time data transmission system has adopted a variety of data communication methods, including short wave communication, Inmarsat-C satellite communication and GPRS/CDMA communication. All kinds of communication modes have their own advantages and limitations. Short wave communication has poor anti-interference ability, high bit error rate and low data receiving rate. Inmarsat-C satellite communication has high reliability and data receiving rate of more than 95%, but the communication cost is high, which is not suitable for data transmission. GPRS/CDMA communication cost is low, but the communication signal is limited by the distance from buoy to shore [9]. According to the technical requirements of the data transmission of the buoy system, iridium data communication is used to transmit large amount of real-time data, which can improve the stability and reliability of the information transmission of the marine monitoring buoy, with the remarkable characteristics of high speed, low signal delay and small signal loss [10]. Based on the above analysis, the application of iridium data communication system in the information transmission of ocean monitoring buoy is described.

2 Application of Iridium Data Communication System in Information Transmission of Ocean Monitoring Buoy

2.1 General Architecture of Iridium Communication System

Iridium BD terminal module 9602 introduced by iridium company is used in iridium communication system. The SBD service of bidirectional real-time short data transmission in the form of data package is mainly used for the application development of regional automation and remote data tracking. In view of the special sea area of marine monitoring buoy, the data transmission is realized by using iridium BD. The SBD service of iridium SBD terminal module 9602 is realized through RS-232C interface, and the baud rate is 19200 bit/s by default. The module can receive up to 270b data or send 340B data at a time, and does not need to install a SIM card. When there is data receiving, it will ring. The average standby current of the module is 5 mA, while the average current of iridium SBD is 95ma and 45 mA respectively. The user application

monitoring center uses iridium SBD terminal module 9602 to transmit and receive data through iridium communication network.

Because the logic level of RS-232C standard is not compatible with the logic level of TTL digital circuit, when the communication interface of iridium SBD terminal module 9602 adopts RS-232C standard, the level conversion of the communication interface should be carried out first when the hardware circuit is connected. In order to realize RS-232C level conversion, the interface device adopts the ax3232e chip of Maxim company, which is a low power consumption level conversion chip with data transmission rate up to 250 kb/s and two transmitters and two receivers. The overall framework of iridium communication system is shown in Fig. 1.

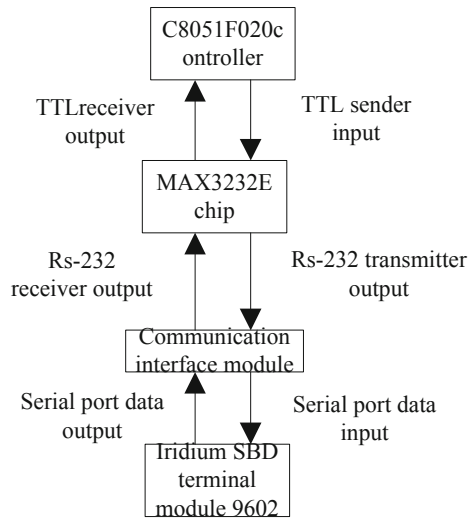

Fig. 1. General framework of iridium communication system

The software core of iridium SBD communication is the development of 9602 driver of iridium SBD terminal module. The software part of its iridium data communication system includes several modules, and its main functions are as follows. The main functions of the data acquisition module include: switching the extended serial port of imp16c554; collecting data according to the communication protocol of each equipment; compiling the collected data. The main function of data transmission module is to dial and transmit data. In the data transmission module, it mainly focuses on three aspects: the first is the processing of the shore station program timeout and unresponsive after dialing successfully; the second is the response timeout retransmission control; the third is the processing of data verification errors in the process of data transmission. The data transmission module packs the transmitted data into frames, each 32 bytes is a frame, and adds CRC16 verification. In the process of data receiving and sending, after the connection between the transmitting module and the receiving

shore station is established, the shore station verifies each received frame of data, and responds to the transmitting module according to the verification results.

The iridium data communication system is applied to the information transmission of marine monitoring buoy, as described below.

2.2 Determination of Buoy Information Transmission Network Protocol

Network communication needs network protocol, so it is very important to choose appropriate network protocol to ensure data transmission. TCP/IP protocol is used as the buoy information transmission network protocol. In the TCP/IP protocol, each terminal has an IP address, and different applications on the terminal have a port number. On the same terminal, different applications can be distinguished according to the port number. There are two kinds of TCP/IP protocols: connection oriented reliable transport protocol TCP and connectionless unreliable transport protocol UDP. When using UDP protocol to communicate, you only need to know the IP address and port number of the other party to send the data. You don't need to establish a connection, but you can't guarantee the integrity of the data, which is prone to data loss. When using TCP protocol to communicate, you should first establish a connection between the two sides of the communication, so as to prepare for the subsequent communication. In TCP communication, data can be confirmed and retransmitted in case of transmission error, so as to ensure that the data will be transmitted to the other party. The communication protocol in this software is TCP/IP protocol based on client/server mode. As a client, the offshore buoy host should actively establish a TCP connection with the server-side shore station receiving system with fixed public IP address and fixed monitoring port, Then the receiving system of the shore station sends the corresponding command to the buoy host through the connected socket, waiting for the buoy host to receive and send the data to the shore station.

2.3 Acquisition of Position Information of Marine Monitoring Buoy

The underwater data acquisition module in the iridium data communication system uses the wave energy to descend by itself, rise to the set depth, and start to collect data. When it rises to a certain distance from the sea surface buoy, the NdFeB magnetic block embedded in the glass fiber reinforced plastic at the top of the data acquisition system will trigger the magnetic sensitive switch circuit embedded in the glass fiber reinforced plastic at the bottom of the buoy to generate the interrupt signal and wake up the main control board in the dormant state. Then, the main control board receives and saves the data from the electromagnetic coupling system through the BCB serial port. After receiving the data, the underwater data acquisition system descends again to collect the data. At the same time, the main control board sends the received data to the monitoring center through the iridium communication terminal, and enters the sleep state again, waiting for the next data arrival.

Assuming that the signal frequency of the ocean monitoring buoy (radiation source) is f_D , when the satellite in the iridium data communication system moves towards the direction close to the radiation source, the signal frequency received by the satellite will be greater than the signal frequency sent by the radiation source f_D , When the satellite

flies over the radiation source and the connection between them is perpendicular to the movement direction of the satellite, the signal frequency received by the satellite will be equal to the signal frequency f_D emitted by the radiation source. When the satellite moves away from the radiation source, the signal frequency received by the satellite will be less than the signal frequency f_D emitted by the radiation source. The relationship between the sending frequency of the radiation source signal and the receiving frequency of the satellite signal can be expressed as follows:

$$f_R = \left(1 + \frac{|v| \cos \theta}{c}\right) f_D \tag{1}$$

Among them, f_R is the signal receiving frequency, v is the speed vector of the satellite, c is the propagation speed of electromagnetic wave in the medium, θ is the angle between the connection between the satellite and the radiation source and the speed direction of the satellite. Assuming that the receiving frequency of the signal from the radiation source is measured by the satellite at t_N time, the included angle θ_N can be calculated according to Formula 1 when the transmitting frequency of the radiation source signal is known. From a geometric point of view, in three-dimensional space, all points with an included angle of θ_N with the direction of satellite movement can form a conical surface with a fixed point of satellite and a conical angle of θ_N . When the radiation source is at any position on the cone surface, the receiving frequency of the satellite for the radiation source signal is equal when the signal transmitting frequency is constant, so the cone surface is also called the equal frequency surface. If the satellite gets two equal frequency surfaces at t_1 and t_2 respectively, If the conic angles of these two equal frequency surfaces are θ_1 and θ_2 respectively, two curves will be formed when the two equal frequency surfaces intersect the earth sphere.

The marine monitoring buoy is considered as a stationary target during the period of satellite visibility. According to the Doppler frequency offset effect, the measurement frequency of the i th received signal can be expressed as:

$$\begin{aligned} f_{ri} &= f_e \left(1 - \frac{V_{si}^T(L_{si} - L_b)}{c|L_{si} - L_b|}\right) + n_i \\ &= f_e \left(1 - \frac{V_{sxi}(x_{si} - x) + V_{syi}(y_{si} - y) + V_{szi}(z_{si} - z)}{c(x_{si} - x)^2 + (y_{si} - y)^2 + (z_{si} - z)^2}\right) + n_i \end{aligned} \tag{2}$$

Among them, f_e is the carrier frequency of the signal, $L_b = [x, y, z]^T$ is the position vector of the marine monitoring buoy in the ECEF coordinate system, $V_{si} = [V_{sxi}, V_{syi}, V_{szi}]^T$, $L_{si} = [x_{si}, y_{si}, z_{si}]^T$ are the speed vector and position vector of the satellite in the i -th positioning respectively, n_i is the signal noise.

According to the signal receiving frequency measured at different times, the position coordinates of the marine monitoring buoy can be located. Because the satellite transmits information on two fixed VHF working channels (161.975 MHz and 162.025 MHz). Therefore, when the carrier frequency of the signal is known and the earth surface equation is combined, two equal frequency surface equations are established, and then the position vector of the ocean monitoring buoy can be obtained by

solving the equations composed of three equations. According to the intersection of these two curves, the position of the ocean monitoring buoy can be determined.

2.4 Information Processing of Marine Monitoring Buoy

The information of ocean monitoring buoy is mainly related to the ocean. The specific processing contents are as follows:

Calculation of meteorological and hydrological data: according to the requirements of coastal observation specification, it is necessary to observe the wind speed and corresponding wind direction, maximum wind speed and corresponding wind direction and its occurrence time, daily maximum wind speed and corresponding wind direction and its occurrence time. The wind parameters are sampled once every 3S, and the wind direction is sampled in integral time of every 3S. Instantaneous wind speed: take the average wind speed of 3S before sampling as the instantaneous wind speed of this sampling. Instantaneous wind direction: add the direction obtained by the electromagnetic compass and the direction of the wind sensor itself, and then put it into the main value range 0–360. At the zero second of every minute, the instantaneous wind data obtained in the previous minute is calculated on a minute average. If 11 valid sampling data are obtained in this minute, the data in this minute will be considered as valid, and one minute average calculation will be carried out, otherwise no processing (no calculation, no storage) will be carried out. The wind speed is calculated by averaging 21 samples from 0 s in the previous minute to 0 s in the current minute. The wind direction is decomposed and added by the vectors of 21 sampling values from 0 s of the previous minute to 0 s of the current minute, and then synthesized. Zero (North) if 0. At the 0 s of every minute, the average wind data of one minute obtained in the last ten minutes is calculated in ten minutes. If there are more than six valid one minute average wind data within the ten minutes, the ten minute data is considered to be valid, and the ten minute average calculation is carried out, otherwise no processing is carried out. The wind speed is the sliding average of the first 11 1 min average wind speeds. The wind direction is the decomposition, addition and synthesis of the first 11 1-minute average wind direction vectors. Zero (North) if 0.

Calculation of air temperature and air pressure parameters: the sampling interval is 3 s, and the air temperature and air pressure values are sampled every 3 s. One minute average value: 21 samples from the first 1 min 0 s to the end of this minute 0 s are obtained by averaging the maximum 3 values and the minimum 3 values.

Calculation of the main wave direction: the wave direction here refers to the external wave direction, which is different from the wave direction that describes the internal structure of the wave. It refers to the direction of each specific wave on the sea surface. The direction of each specific wave on the sea surface is generally different, so the main direction of each specific wave at a certain time is called the main wave direction. The wave in the actual ocean is very complex. When the system calculates the wave direction, the wave on the sea surface is simplified as a two-dimensional single wave. When the buoy is in the direction from the wave peak to the wave trough, the direction of the buoy inclination is the wave direction. It is divided into 16

directions, with the geographic north direction as zero degree, and calculated in a clockwise direction. The relationship between the direction and the angle is shown in Table 1.

Table 1. Orientation and angle

Bearing	Degree/°	Bearing	Degree/°
N	348.76–11.25	S	168.76–191.25
NNE	11.26–33.75	SSW	191.26–213.75
NE	33.76–56.25	SW	213.76–236.25
ENE	56.26–78.75	WSW	236.26–258.75
E	78.76–101.25	W	258.76–281.25
ESE	101.26–123.75	WNW	281.26–303.75
SE	123.76–146.25	NW	303.76–326.25
SSE	14.25–168.75	NNW	326.26–348.75

As shown in Table 1, the wave sensor finally transmits the wave direction occurrence rate of 16 directions (360° bisection), and the azimuth with the largest occurrence rate is the main wave direction. The main wave direction is usually calculated by drawing direction spectrum. Direction spectrum (two-dimensional spectrum) can show the distribution of component wave energy according to frequency and propagation direction at the same time. After analyzing the direction spectrum, the main wave direction can be obtained. The wave sensor obtains the wave direction occurrence rate of 16 directions. In order to calculate the azimuth with the largest occurrence rate, this paper adopts the sliding average filtering method for the main wave direction. The 16 wave occurrence rates are grouped, and the average of each wave occurrence rate is calculated by adding before and after. The largest set of calculated numbers is the main wave direction.

Calculation of wave height and period: according to GB/t14914-2006 code for coastal observation, wave height and period eigenvalues and their codes are defined as follows:

Maximum wave height (Hmax): the maximum value of wave height in continuous wave records;

Maximum wave period (Tmax): the period corresponding to the maximum wave height;

One tenth of the wave height (H1/10): the average value of the first one tenth of the total wave height in successive wave records, arranged from large to small;

One tenth period of large wave (T1/10): the average value of each period corresponding to each wave height of one tenth of large wave;

Effective wave height (H1/3): the average value of the first third of the total wave height in successive wave records, arranged from large to small;

Effective wave period (T1/3): is the average value of the corresponding period of each wave height of the effective wave height;

Average wave height (hmean): it is the average value of all wave heights in continuous wave records;

Tmean: is the average value of the period corresponding to each wave height of the average wave height; Average wave height hmean is a basic characteristic quantity, which represents the average value of each wave height, and can roughly reflect the average state of sea wave height. The average wave height of some large waves, such as the effective wave height and the one tenth of the wave height, represent the significant part of the waves, which are concerned in general navigation and port design; the maximum wave height Hmax is the maximum value of the observed wave height, which is also the most important in practical application. What kind of wave height is used in practical application depends on the purpose of actual use. The wave sensor of this system can measure all these characteristic wave heights with some representative significance. Daily statistical calculation of meteorological and hydrological data: the system is set to work in a fixed time mode, once every half an hour, and other parts are powered off to achieve the maximum power saving; the buoy system can also receive the control command sent by the processing system according to the shore station data, and switch between the working mode of one hour and half an hour. We make daily statistics according to the received and stored meteorological and hydrological data and display them on the real-time interface. According to the knowledge of ocean observation, the daily statistical value of meteorological parameters is updated at 20:00 every day, and the hydrological parameters are updated at 0:00 every day. The essence of daily statistical calculation of data is to read the database and use SQL statements to calculate the data. Several main SQL math functions are used: AVG: arithmetic average; COUNT: count records; FIRST and LAST: return the last data in the first data field of a field; Max and Min: return the maximum and minimum values of a field; sum: return the SUM of a specific field or operation.

2.5 Upload of Information of Marine Monitoring Buoy

The information needed to be transmitted by the marine monitoring buoy includes marine meteorological and hydrological data, acoustic array, acoustic fingerprint information and video information. By default, the marine meteorological and hydrological data are uploaded once every half an hour, and each packet of data is about 1.2 kb. The sound information is transmitted every 10 min, and there are three kinds of data packets with different contents according to different settings. The specific content form of every 1 min packet is as follows: content 1: it is the basic transmission packet, including packet time, array attitude information (depth, roll, pitch, true direction), detection sign, target direction and reserved part. The size of content 1 packet is about 9.6 kb. Content 2: add processing results (C4 band beamforming results) on the basis of basic transmission packets, and the content 2 packet size is about 350 kb. Content 3: on the basis of content 2 packet, the processing result (beam domain data) is added, and content 3 packet size is about 1.5 MB. Video information is uploaded once an hour, and the amount of data transmitted is about 30 MB. It can be seen that the amount of information transmitted by buoy to shore station data receiving and processing system is very large, and at the same time, it is necessary to ensure that the data is sent to shore station safely, reliably and accurately. After receiving the data,

according to the communication protocol between the shore station and the buoy host, first determine whether the command code is 0x01 sent by the buoy host. After the authentication is successful, send the data query command. The shore station becomes the main controller, waiting for the buoy host to send the data. After receiving the data, analyze the logarithmic data, Set different elements into different arrays, and store the parsed data in different arrays for convenient display and storage.

In conclusion, iridium data communication system is applied to the information transmission of marine monitoring buoy, which improves the real-time performance of the information transmission of marine monitoring buoy.

3 Experiment

The iridium data communication system is applied to the information transmission of marine monitoring buoy, and compared with other information transmission methods of marine monitoring buoy to verify whether the iridium data communication system applied to the information transmission of marine monitoring buoy can improve the transmission speed of marine monitoring buoy information.

3.1 Experimental Process

Firstly, the information parameters of the ocean monitoring buoy are set. Some parameter information is shown in Table 2.

Table 2. Partial parameter data transfer format table

Byte symbol	Data values	Byte meaning
1	Way to work	0: Dormancy mode 1: Way to work Others: reserved
2	Buoy attitude information upload mode	0: Instructions to upload 1: Implementation of transmission Others: reserved
3	Data upload mode	0: Automatically upload 1: Real-time transmission Others: reserved
4	Update the logo	0x91: Instruction parameter update 0x92: Instructions to update 0x93: Parameters are updated Others: reserved

After setting the parameters, the iridium data communication system is used to transmit the information of the marine monitoring buoy, and the real-time transmission is tested, which is expressed by the time of information transmission, and compared

with the traditional method of information transmission of the marine monitoring buoy. In order to ensure the accuracy of the experiment, five experiments were carried out.

3.2 Analysis of Experimental Results

Using two kinds of information transmission methods of marine monitoring buoy, the comparison results of information transmission time are shown in Fig. 2.

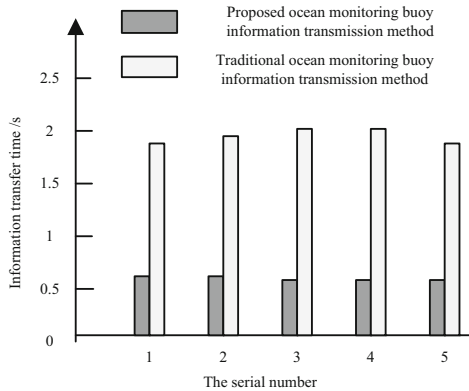

Fig. 2. Information transmission rate comparison results

It can be seen from Fig. 2 that the information transmission time of traditional marine monitoring buoy information transmission method is between 1.8–2 s, while that of iridium data communication system applied to marine monitoring buoy information transmission method is about 0.6–0.7 s. Through comparison, it is found that the iridium satellite data communication system is applied to the information transmission method of marine monitoring buoy, which significantly improves the transmission speed of the information of marine monitoring buoy, indicating that the proposed information transmission method of marine monitoring buoy has higher real-time performance and stability.

4 Conclusion

In view of the poor real-time transmission of the traditional marine monitoring buoy information, the iridium satellite data communication system is applied to the marine monitoring buoy information transmission, which improves the shortcomings of the traditional method. Through the comparative experiment, the information transmission speed is improved by comparing with the traditional marine monitoring buoy information transmission method. It is hoped that it can provide some basis for the study of the information transmission method of the ocean monitoring buoy.

References

1. Duan, S.: Design for STM32-based automatic data transceiver system of HM2000 iridium buoy. *Mine Warfare Ship Self-Defence* **25**(4), 46–50 (2017)
2. Zhang, S., Wang, D., Shen, R.: Design of a data automatic transceiver for HM2000 iridium profiling float. *J. Ocean. Technol.* **37**(5), 53–59 (2018)
3. Zhang, H., Dou, Y., Chen, Y., et al.: Design and application of sea-ice-gas unmanned ice station monitoring system for Arctic. *Chin. J. Electron. Devices* **42**(3), 749–755 (2019)
4. Zheng, Y., Zhao, Y., Liu, W., et al.: Forest microclimate monitoring system based on Beidou satellite. *Trans. Chin. Soc. Agricult. Mach.* **49**(2), 217–224 (2018)
5. Hu, S., Dou, Y., Ma, C., et al.: Design and application of arctic sea ice comprehensive monitoring system based on iridium 9602. *Mod. Electron. Tech.* **41**(20), 127–131 (2018)
6. Xu, L., Hou, Z., Yan, S., et al.: Design of a wireless real-time observation data transmission system for deep ocean mooring. *Telecommun. Sci.* **34**(6), 29–35 (2018)
7. Wang, Y., Yu, H., Yang, J.: Investigation on satellite technology for rapid report data transmission. *Seismol. Geomagn. Obs. Res.* **38**(4), 203–206 (2017)
8. Chen, X., Liu, B.: Application of real-time monitoring buoy in monitoring red tide. *J. Trop. Oceanogr.* **37**(5), 20–24 (2018)
9. Zhao, J., Wang, Z., Hui, L., et al.: Design of a marine multi-point water quality monitoring system based on underwater acoustic communication. *J. Dalian Fish. Univ.* **32**(6), 747–752 (2017)
10. Kong, W., Yang, Z., Ma, S.: Design of ultra-low power consumption ocean drifting buoy collector based on MSP430. *Mod. Electron. Tech.* **40**(20), 146–149 (2017)