



# A Space-Time Jointing Moving Target Detection Method for FMCW Radar

Ming Li<sup>1</sup>, Mingqian Liu<sup>2(✉)</sup>, and Shouzhong Zhu<sup>3</sup>

<sup>1</sup> State 722 Factory, Guilin 541001, Guangxi, China

<sup>2</sup> State Key Laboratory of Integrated Service Networks, Xidian University,  
Xi'an 710071, Shaanxi, China  
mqliu@mail.xidian.edu.cn

<sup>3</sup> Hunan Positive Ship Technology Co., Ltd., Changsha 410075, Hunan, China

**Abstract.** Point to the problem of small target detection in single channel linear frequency modulation continuous wave (FMCW) radar, this paper proposed a Space-time jointing moving target detection method, the method combined single channel in the process of the radar scanning form different continues pulse interval (CPI) for ground clutter cancellation and target detection, by using adaptive target detection processing, this method can improve the ability of the ground clutter suppression, and increase the performance of ground moving target detection. The simulation result based on the real radar data shows validly of the method.

**Keywords:** Frequency modulation continuous wave · Ground clutter suppression · Adaptive target detection · Airborne radar · Digital radio frequency memory

## 1 Introduction

The relevant information of the ground target can be provided by the portable ground reconnaissance radar adopting the linear frequency modulation continuous wave (LFMCW) [1]. With the development of radar electronic technology, the Armies of various countries are paying more and more attention to portable ground reconnaissance radar equipment, and this type of radar will become more popular in infantry equipment. At the same time, LFMCW radar as a ground surveillance radar has broad application prospects, especially for small detection. Usually ground radar receives target echo data, uses MTD processing, and then removes the Doppler channel where ground clutter is located. Because the beam has a certain width, the target will have a certain scanning time in the beam,

---

This work was supported by the National Natural Science Foundation of China under Grant 62071364, in part by the Aeronautical Science Foundation of China under Grant 2020Z073081001, in part by the Fundamental Research Funds for the Central Universities under Grant JB210104, and in part by the 111 Project under Grant B08038.

which corresponds to multiple coherent processing pulse groups for mechanical scanning radar. The current project is mainly to perform MTD processing on the coherent signal in each CPI [2,3], and then perform target judgment on multiple pulse groups according to certain criteria. For ground targets, since the scattering characteristics of ground clutter in the beam are basically the same, the conventional directly MTD processing has insufficient suppression of ground clutter, and the detection ability of some low-speed small targets is insufficient, such as pedestrians and small drone [4,5].

Space-time adaptive signal processing (STAP) was firstly proposed in the study of airborne early warning radar clutter suppression [6,7]. Combined with the characteristics of space-time two-dimensional adaptive signal processing, a long coherent processing time was divided into several A short period of time to deal with. In a short time, the DOA and Doppler frequency are unchanged, and the adaptive weight is estimated to suppress clutter with the radar echo data in a short time. Aiming at the problem of small slow target detection for LFMCW radar, this paper proposes A Space-time Jointing Moving Target Detection Method, which combines different coherent pulse groups in the radar scanning process for ground clutter cancellation and target detection and uses multiple coherent pulse processing interval data are used for adaptive target detection processing. The method improves the performance of single-channel MTD target detection and processes the actual single-channel LFMCW radar data. The actual radar data processing results show that the method can effectively improve the effectiveness of the single-channel LFMCW radar's detection ability for low-speed and small targets.

## 2 Radar Echo Signal Model

The principle of de-chirp pulse compression processing is to use the same FM slope signal as the transmitted signal as a reference signal, and after mixing with the echo signal, the time difference between the two is converted to a difference frequency. After the analog-digital converter (ADC) and discrete Fourier transform (DFT) processing, the distance information of the target can be obtained, and the detection of the moving target can be completed. The principle of LFMCW radar is shown in Fig. 1.

Assume that the radar emits a frequency-modulated continuous wave signal as follows:

$$s(t) = \text{rect}\left(\frac{t}{T}\right) \exp\left[j2\pi\left(f_0 t + \frac{1}{2} k t^2\right)\right] \quad (1)$$

In the above formula,  $f_0$  and  $B$  is the signal center frequency and the signal bandwidth,  $T$  and  $k = B/T$  represent the signal pulse repetition period and the signal chirp slope respectively. The following discussion ignores the signal amplitude and envelope information, and only considers the phase change. The echo received by the radar can be expressed as follows:

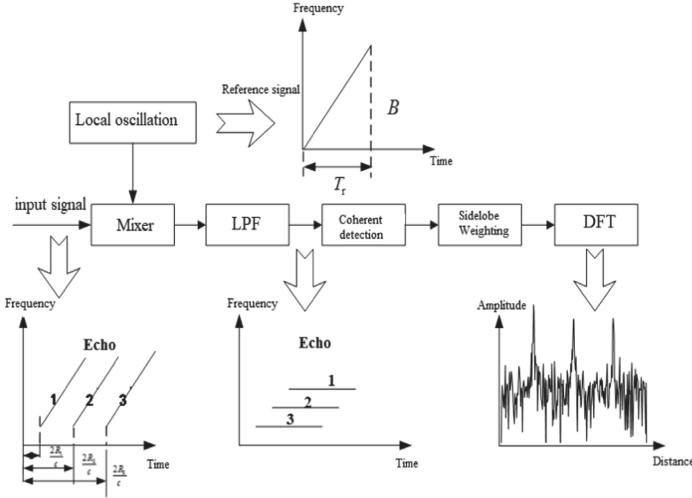

Fig. 1. The diagram of LFM CW radar schematic.

$$s_r(t) = \text{rect}\left(\frac{t - \tau_r}{T}\right) \exp\left[j2\pi\left(f_0(t - \tau_r) + \frac{1}{2}k(t - \tau_r)^2\right)\right] \quad (2)$$

Here,  $\tau_r = 2(R_0 - vt)/c$  represents the target transmission delay, where  $R_0$  is the initial radial distance between the target and the radar,  $c$  and  $v$  is the speed of light and the target’s radial velocity relative to the radar, respectively. The reference signal with the same frequency modulation slope as the transmitted signal is expressed as:

$$s_{ref}(t) = \text{rect}\left(\frac{t - \tau_{ref}}{T_{ref}}\right) \cdot \exp\left[j2\pi\left(f_0(t - \tau_{ref}) + \frac{1}{2}k(t - \tau_{ref})^2\right)\right] \quad (3)$$

Where  $\tau_{ref} = 2R_{ref}/c$  is the delay of the reference signal relative to the transmitted signal,  $R_{ref}$  and  $T_{ref}$  is the reference distance and the pulse width of the reference signal. It is worth noting that  $T_{ref}$  is usually slightly larger to  $T$  ensure that all echoes can be mixed with the reference signal. The output signal is made up of  $s_r(t)$  and  $s_{ref}^*(t)$ , the details are as follows:

$$\begin{aligned} s_o(t) &= s_r(t) \cdot s_{ref}^*(t) \\ &= \text{rect}\left(\frac{t - \tau_r}{T}\right) \cdot \text{rect}\left(\frac{t - \tau_{ref}}{T_{ref}}\right) \cdot \exp\left\{j\left[2\pi f_0(\tau_{ref} - \tau_r) + 2\pi k t(\tau_{ref} - \tau_r) + \pi k(\tau_r^2 - \tau_{ref}^2)\right]\right\} \\ &= \text{rect}\left(\frac{t - \tau_r}{T_{ref} \cap T}\right) \cdot \exp\left[j(2\pi f_b t + \varphi)\right] \end{aligned} \quad (4)$$

Where  $\varphi = 2\pi f_0(\tau_{ref} - \tau_r) + \pi k(\tau_r^2 - \tau_{ref}^2)$  and  $f_b = k(\tau_{ref} - \tau_r)$ . From the above derivation, it can be seen that after the signal is dechirp, a single-frequency signal with a constant frequency is output, and the frequency value of the output signal is proportional to the difference between the delay of the reference signal and the delay of the echo signal.

The relative distance between the target and the reference position, defined as

$$\Delta R = \frac{1}{2}c(\tau_r - \tau_{ref}) = -\frac{1}{2} \cdot \frac{cf_b}{k} \tag{5}$$

The actual distance between the target and the radar transmitter, defined as

$$R_0 = \frac{1}{2}c\tau_r = R_{ref} + \Delta R = R_{ref} - \frac{1}{2} \cdot \frac{cf_b}{k} \tag{6}$$

### 3 Detection of Moving Target

Usually the LFMCW of the radar is transformed by DFT to produce a one-dimensional range profile, a frequency-domain range profile, and then perform MTD processing on the echoes of each group of CPI and the same range unit to obtain Doppler velocity information. Finally, two-dimensional CFAR is used for target detection. The detailed detection process is as follows.

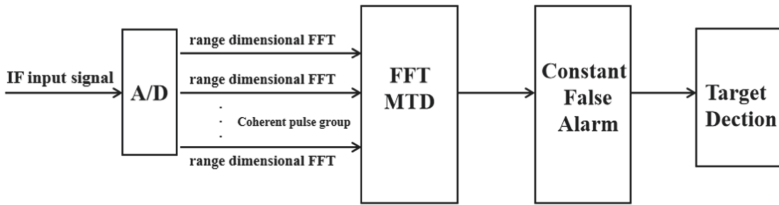
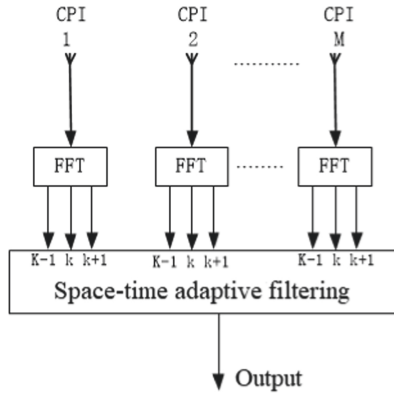

Fig. 2. The conventional LFMCW radar signal processing.

The current project mainly performs MTD processing on the coherent signals in each CPI, and then performs target determination on multiple pulse groups according to certain criteria. For example, if multiple CPIs meet the discovery target of 0.8 or more, it is considered that there is a target. In practice, since the statistical characteristics of ground clutter in a beam are basically similar in the mechanical scanning process, it is considered that the idea of using space-time adaptive processing can be adopted to combine multiple CPIs to achieve detection enhancement of slow ground targets.

It is proposed to use Doppler channels in different CPIs to perform adaptive processing technology for clutter suppression. First, the MTD results of each CPI are combined, and then the output of three Doppler channels is processed adaptively, thus Ground clutter is filtered out.

Figure 3 shows the processing structure for filtering clutter with dimensionality reduction. After the Doppler is localized by the weighted DFT, the output data of three adjacent channels are sent to the adaptive processing for processing.



**Fig. 3.** Structure of 3DT-SAP dimensionality reduction.

The processor can describe digital optimization problems as:

$$\begin{cases} \min W^H R W \\ s.t. W^H S = 1 \end{cases} \tag{7}$$

$R = E [X X^H]$  and  $S = S_s \otimes S_t$  denote as the co-variance matrix and the two-dimensional steering vector respectively, where  $S_s = [1, 0 \dots 0]^T$  and  $S_t = [1, e^{j\omega_t} \dots e^{j(N-1)\omega_t}]^T$ . And  $\omega_t$  Indicates the phase of each Doppler multichannel processed by MTD.

Finally, the optimized weight vector can be solved by the above formula.

$$W_{opt} = \mu R^{-1} S \tag{8}$$

Where  $\mu$  is a constant. It can be seen that the expression is composed of the clutter covariance inverse matrix and the target vector. The first part is equivalent to whitening the clutter, and the latter part is equivalent to the target signal Perform matched filtering, so this is actually a generalized Wiener optimized matched filter.

The whole radar signal processing block diagram based on joint multi-CPI target detection is shown in Fig. 4.

Compared with the traditional method, the multi-frame processing results are jointly processed to realize the detection of slow targets on the ground, which can be applied to the existing single-channel LFMCW radar. The detailed implementation steps of the algorithm in this paper are as follows:

- 1) The received intermediate frequency data is calculated by the distance dimension FFT, and then FFT transformation is performed on the K coherent signals of each CPI according to the coherence.
- 2) Filter the results of N MTD processing in the beam scanning process and rearrange the data, where N is the number of coherent processing in the beam, and the first Doppler channel is selected as the main channel.

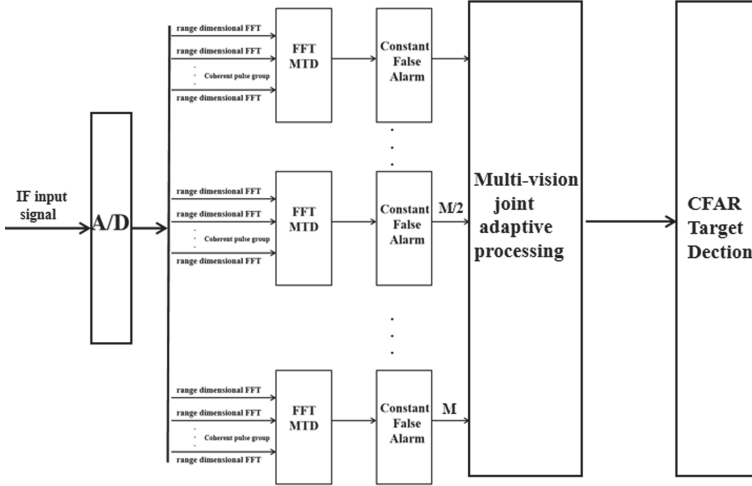

Fig. 4. Diagram of Jointed process.

- 3) The co-variance matrix formed by the received data. At the same time, define as a two-dimensional steering vector.

$$R = E [X X^H] \tag{9}$$

$$S = S_s \otimes S_t \tag{10}$$

$$S_s = [1, 0 \dots 0]^T \tag{11}$$

$$S_t = [1, e^{j\omega_t} \dots e^{j(N-1)\omega_t}]^T \tag{12}$$

- 4) The optimized weight vector can be rewritten as the above formula.

$$W_{opt} = \mu R^{-1} S \tag{13}$$

$$\mu = 1/S^H R^{-1} S \tag{14}$$

- 5) The first Doppler channel composed of each joint channel is subjected to clutter suppression processing according to the adaptive weight vector  $W$ .

$$Y_k = W^H_{opt} X \tag{15}$$

- 6) Screen the second Doppler channel, repeat steps 3–5 to achieve clutter suppression for all Doppler channels  
 7) The result of moving target detection is formed by using CFAR to detect the target from the suppressed range Doppler image of each channel.

## 4 Simulation Results

According to the measured echo data of the real LFM CW ground reconnaissance radar, the overall shape of the radar is shown in Fig. 5. The radar is a ground-mounted radar, which is mainly used for the reconnaissance of slow targets on the ground. It works in the X frequency band, with a range detection accuracy of 10 m, and a sweep period of 1000 Hz. The cumulative number of sweeps for a single MTD process is 64, There are 8 CPIs for each scan target in the main lobe beam. Take a section of measured data with a distance ranging from 3000 m to 6000 m for analysis. The distance Doppler image of the ground echo after a traditional single MTD is shown in Fig. 6.



Fig. 5. LFM CW radar physical object.

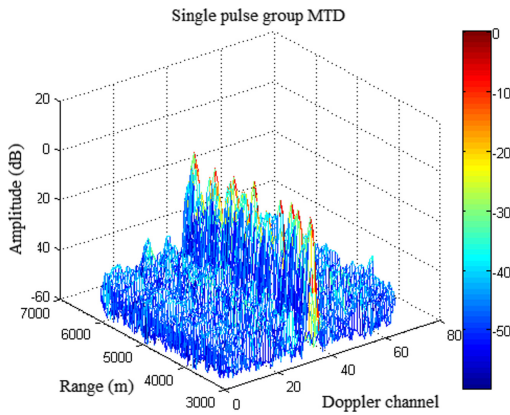

Fig. 6. Three-dimensional Range-Doppler image of echo.

In actual radar detection, if a target is detected more than 5 times in 8 CPIs, it is considered that the target exists. After adopting multi-CPI adaptive cancellation of text, it can effectively realize the detection and enhancement of the original ground clutter and the ground slow and small targets. Figure 7 is the three-dimensional range Doppler image after the 8-detection joint adaptive processing. It can be seen that after the joint processing, the ground clutter can be effectively suppressed, and the ground target can be better detected at the same time.

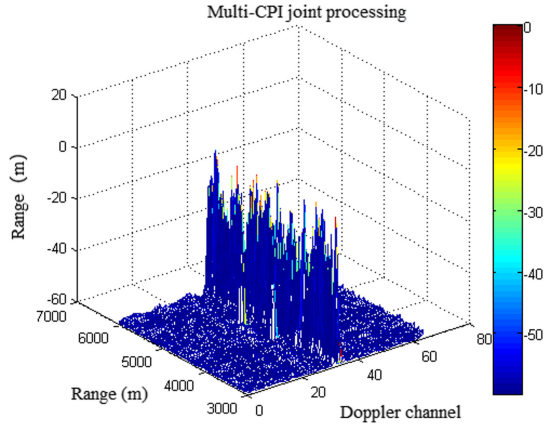

Fig. 7. Range-Dopple image of joint-cancellation.

Figures 8 and 9 are Range-Dopple images used for CFAR detection. It can be seen that the method can effectively suppress ground clutter and noise, especially

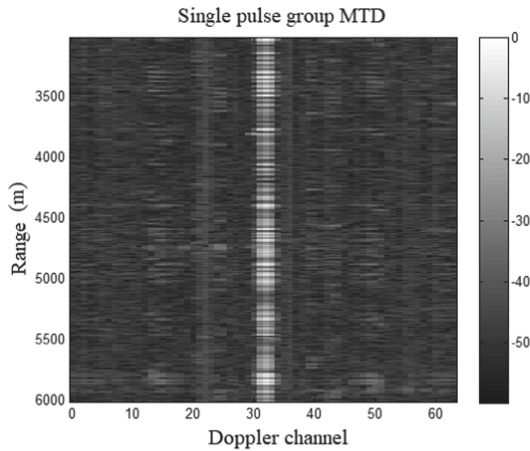
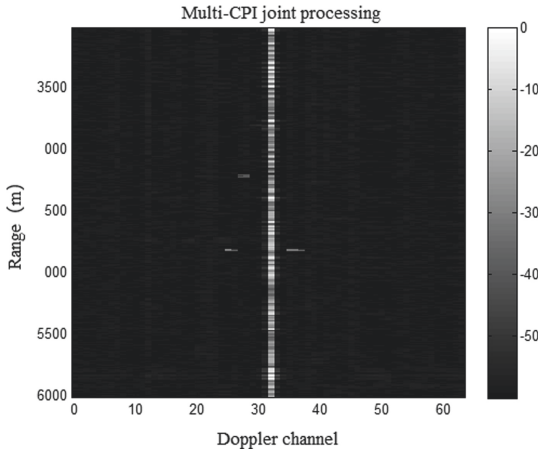

Fig. 8. Range-Dopple image of single-channel.

the detection ability of slow targets on the ground can be greatly improved. Currently, mechanical scanning radars urgently need to improve the detection ability of targets when detecting slow targets on the ground and at low altitudes. Through this solution, the detection performance of slow small targets can be quickly improved without modifying the existing radars.



**Fig. 9.** Range-Dopple image of Joint-channel.

The main clutter suppression and target detection capabilities are significantly improved through the joint processing. Figures 10 and 11 are the comparison of the Doppler channel clutter suppression capabilities after the original single-channel MTD processing and the combined processing. Obviously, when the joint processing is not performed, the radar does not have the detection capability for low-speed targets near the main lobe and cannot effectively achieve target detection. However, the clutter of the entire Doppler channel is reduced by nearly 16 dB on average through the joint processing, so that the slow target that was originally annihilated in the ground clutter can be effectively detected.

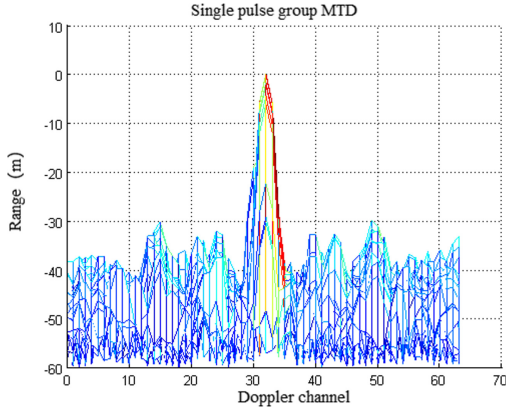

Fig. 10. Single-channel MTD target amplitude comparison.

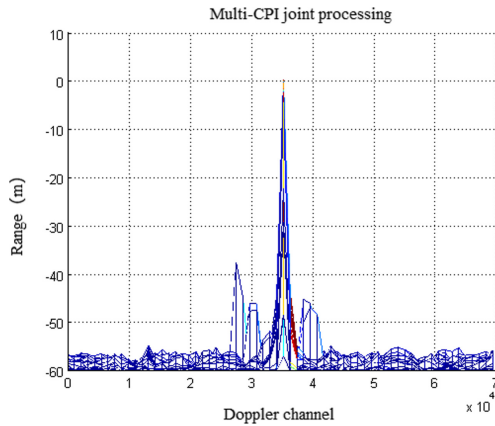

Fig. 11. Comparison of target range for joint processing.

## References

1. Liu, G.S., Sun, G.M., Gu, H., et al.: Continuous wave radar and its signal processing technology. *Modern Radar* **17**(6), 20–36 (1995)
2. Gu, D.M.: Continuous wave radar signal recognition and parameter extraction technology research. Master’s thesis, Nanjing University of Information Technology, pp. 44–46 (2009)
3. Dai, L., Gao, M.G.: Application of uniform DFT filter bank in radar jamming system. *J. Syst. Eng. Electron.* **17**(3), 527–530 (2006)
4. Gürbüz, S.Z., Melvin, W.L., Williams, D.B.: Detection and identification of human targets in radar data. In: *Signal Processing, Sensor Fusion, and Target Recognition XVI*, vol. 6567 (2007)

5. Zhou, Y.S.: Research on human body detection and feature extraction algorithms based on micro-Doppler. Master's degree thesis of University of Electronic Science and Technology of China (2010)
6. Shen, J.Q., Jiang, D.X.: Intermittent sampling and forwarding jamming of early warning radar STAP. *Ship Electron. Warfare* **40**(3), 21–25 (2017)
7. Zhou, Y., Wang, X.G., Duan, R.: An improved JDL-STAP algorithm for airborne early warning radar. *Chinese J. Radio Sci.* **25**(6), 1052–1057 (2010)