



# Design of Buoy Positioning System for Ocean Monitoring Based on Visual Feature Recognition

Ye Liu<sup>1,2,3(✉)</sup> and Lei Liu<sup>1,2,3</sup>

<sup>1</sup> Institute of Oceanographic Instrumentation, Qilu University of Technology (Shandong Academy of Sciences), Qingdao, China

ly0822cn@163.com

<sup>2</sup> Shandong Provincial Key Laboratory of Ocean Environmental Monitoring Technology, Qingdao, China

<sup>3</sup> National Engineering and Technological Research Center of Marine Monitoring Equipment, Qingdao, China

**Abstract.** Because the latitude and longitude feedback of the traditional ocean monitoring buoy is not accurate, a method of ocean monitoring buoy positioning based on visual feature recognition is proposed. By selecting buoy shape and material, the communication module and image acquisition module are designed Complete hardware design. In the software design, according to the angle between the lowest pixel, the highest pixel and the horizontal direction, the positioning analog signal is selected. Through the E-R model and the buoy information table field, the database design is completed. So far, the design of the buoy positioning system based on visual feature recognition is completed. According to the simulation results, the longitude and latitude coordinates of the design system feedback can be accurate to four decimal places, which shows that the designed positioning system is more accurate.

**Keywords:** Visual feature recognition · Marine monitoring buoy · Positioning system design

## 1 Introduction

The sea is the origin of life, containing countless treasures and resources. The rational use and development of the oceans have an important impact on our economic development and social progress. At the same time, various natural disasters caused by the oceans also have a huge impact on social development and human life. China's marine disasters are relatively serious, which are affected by marine pollution, red tide, typhoon, storm surge and so on. It is urgent to strengthen the monitoring and research of marine environment [1]. At present, the main methods for locating buoys are GPS, simulated annealing and extended Kalman filter. Among them, GPS technology is to send the buoy signal to the remote monitoring center through the wireless GPRS network, and use the network technology to obtain the buoy positioning information.

The simulated annealing algorithm can locate the target effectively by establishing the target function of the buoy system and establishing the reasonable receiving and stopping criterion. The extended Kalman filtering algorithm uses the relative azimuth information of the aerial sonar buoy and the aircraft to determine the position of the buoy. However, the longitude and latitude feedback of the traditional marine monitoring buoy positioning system is not accurate enough, so a visual feature recognition based marine monitoring buoy positioning system is designed. Visual feature recognition is a method of feature recognition based on the main features of the content image (such as color, texture, and shape). Visual feature recognition is not only applied in the field of computer, but also widely used in industrial design, civil architecture and geographic mapping. For example, in the production of industrial equipment parts, through the application of visual feature recognition method, it can be intuitively analyzed whether there are defects in the shape of parts. This paper will carry out buoy positioning through this mechanism. The innovation point of this paper is that when setting the buoy position, the camera is used for pixel calibration, and some sampling points are selected on the spatial physical coordinate plane, the pixel coordinate difference is considered, and the relative uniform part of the difference is selected to set, thus the scientific distribution of the buoy position is raised.

## **2 Design of Buoy Positioning System for Ocean Monitoring Based on Visual Feature Recognition**

Marine monitoring technology is a comprehensive high-tech which integrates computer, information and sensors, database, remote communication and other disciplines. It integrates the development achievements of many disciplines and represents the development frontier of high technology. With the development of related disciplines and technologies, real-time image processing technology has been more and more integrated into various fields of society. As an important part of the three-dimensional monitoring network of marine environment, the marine buoy monitoring system based on real-time monitoring image has the advantages of stable operation, strong resistance to external damage, large bearing capacity and long working time [2]. A positioning system is designed for the marine monitoring buoy, including the buoy system, shore station receiving system and upper computer. The overall structure is shown in the figure below (Fig. 1):

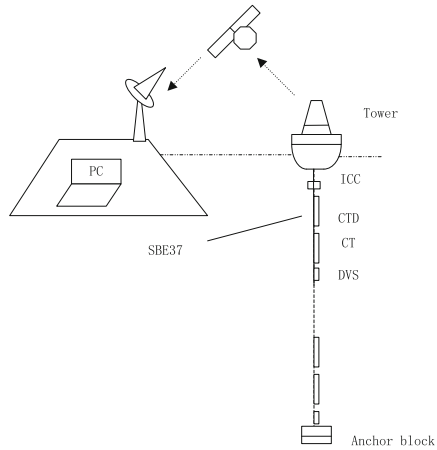

**Fig. 1.** Marine monitoring buoy positioning system

The hardware design of buoy positioning system mainly includes buoy body, power supply system module, protective equipment, sensor, anchoring system. In the software design, we make full use of DSP/BIOS real-time operating system and scom communication module to manage various tasks, and use TI's class/micro driver model and CSL's API to optimize the algorithm design. This design not only improves the utilization rate of driver code, but also ensures the real-time positioning of the system [3]. Next, the hardware and software of the system are designed respectively.

### 3 Hardware Design

#### 3.1 Design Buoy

It mainly includes buoy components, batteries, solar panels and various sensors, etc. To prove that the foundation of stable operation of buoy on the sea surface is similar to the cone-shaped buoy, as shown in the following figure (Fig. 2):

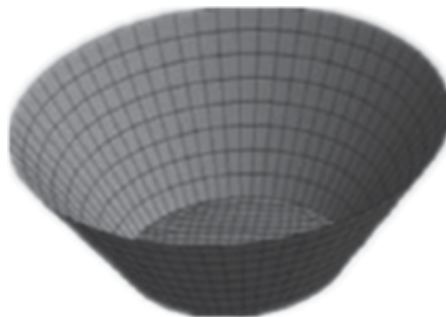

**Fig. 2.** Cone like floating body

Therefore, the design of the buoy is very important. It is necessary to analyze the wave response of the conical buoy in this paper. By analyzing the roll response and heave response, the buoy shape that is most suitable for the design conditions of this paper is selected [4]. According to the size of the conical buoy, the deck diameter is 3 M, the bottom diameter is 1.5 m, the depth and draft are 0.4 m, and the displacement is 3 T. The Rao (floating body response under the action of unit regular wave amplitude) of the target at different wave angles has the following response function with time under simple harmonic  $R(\omega, \beta, t)$ :

$$R(\omega, \beta, t) = AR_e \left[ |H(\omega, \beta)| e^{i(\omega t + \varphi)} \right] * \tag{1}$$

In formula (1),  $A$  is the incident amplitude value;  $R_e$  is the heave response;  $H(\omega, \beta)$  is the transfer function;  $e^{i(\omega t + \varphi)}$  is the frequency. As for the selection of the material of the buoy, it is very important for the stable and continuous operation of the buoy. Especially in the sea areas with high temperature, high salinity and frequent sea conditions in South China, the influence of target materials is very obvious. At present, the buoy materials at home and abroad are mainly steel, plastic and chin alloy. Their comparisons are as follows (Table 1):

**Table 1.** Performance comparison of buoy materials

Floating body material	Anticorrosive	Advantage	Disadvantages
Steel	Poor	Mature, low cost	Easy to corrosion
Stainless steel	Good	Heat and high temperature resistance, a wide range of applications, many categories	The high cost
Engineering plastics	Good corrosion resistance	High rigidity, high mechanical strength	The price is expensive and the output is small

Comparing the anticorrosive properties, merits and demerits and cost of several materials, the standard skeleton of the buoy chooses 316 stainless steel with good corrosion resistance. The buoyancy chamber of the standard body selects EVA material as the foam floating body to provide support for the buoy. So far, the design of the buoy body has been completed.

### 3.2 Design Image Acquisition Card

Real time image processing technology has been more and more integrated into various fields of society. As an important part of the three-dimensional monitoring network of marine environment, the marine buoy monitoring system based on real-time monitoring image has the advantages of stable operation, strong resistance to external damage,

large bearing capacity and long working time [5]. Image acquisition card is the foundation of buoy positioning system based on visual feature recognition. It needs to meet the requirements of miniaturization, lightweight, low power, long life, safety and no pollution. At present, most of the offshore buoys are powered by batteries and solar panels. Due to the constraints of the environment and battery life of the offshore buoys, the batteries need to be replaced every three months or so. Based on the existing power supply equipment, this paper designs the image acquisition card, uses the new marine energy (wind energy, wave energy) to realize the self power supply of the acquisition card, extends the maintenance free period, and ensures the long-term stability of the buoy. First, the circuit connection diagram of the acquisition card is designed as shown in the following figure (Fig. 3):

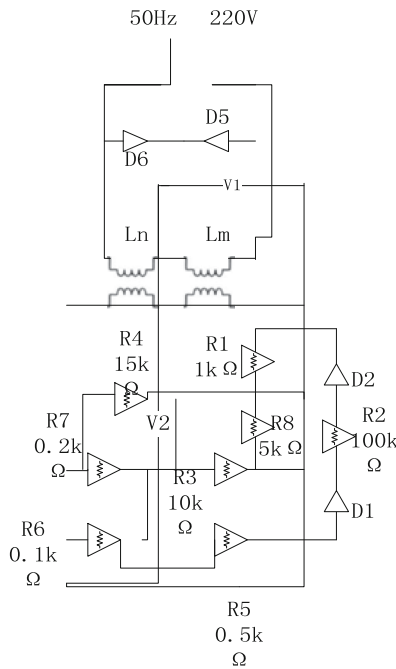

**Fig. 3.** Circuit connection diagram of acquisition card

Description of the circuit connection diagram of the acquisition card: in the whole circuit board, if the power start button is started, the contactor Ln is powered on and self-locking, and the normally open contacts d5 and D6 are closed, the whole acquisition card circuit board is powered on. The control signal is fed back to the lower computer through R1 1 kΩ serial interface, to ensure that the acquisition card drives the horizontal or vertical DC motor to rotate in the positive and negative directions according to the acquired control signal [6]. The control voltage of the circuit board is realized by two switch type step-down regulators D1 and a single channel analog

switch. According to the analog switch of control signal management channel, the acquisition card selects a reasonable resistance, and then regulates the output voltage. So far, the hardware design of the system has been completed.

### 4 Software Design

The working environment of the designed and developed buoy positioning system is long-term, continuous and unattended. Considering that LabVIEW software has powerful functions, flexible programming and friendly human-computer interface, it is specially selected as the foreground development tool, while SQL server has powerful data management functions, as a network database, and the system functions realized by the monitoring system are shown in Fig. 4:

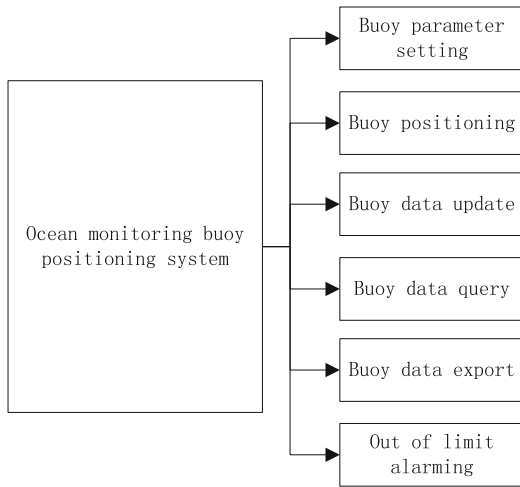

Fig. 4. Functional structure diagram of marine monitoring buoy positioning system

Next, the software of the detection buoy positioning system is designed.

#### 4.1 Select Positioning Analog Signal

Analog signal includes current signal and voltage signal, which are located through serial port. The system obtains the target information through two CCD cameras [7]. Based on the principle of binocular vision (head up binocular vision principle, and some adjustments are made), the triangle relationship between the target point and two cameras is used to locate the target. The system studies the target positioning according to the following steps: first, determine the position and orientation of the two buoy cameras in the work area, the distance between the two cameras (baseline distance); determine the corresponding relationship between the pixel coordinates and the physical angle; use the triangle principle to calculate the physical coordinates of the

intersection of the two projection lines. Select a number of sampling points on the existing spatial physical coordinate plane (sampling at equal intervals), find out the pixel coordinates of the camera corresponding to the sampling points, observe the pixel coordinates corresponding to each sampling point, verify the pixel coordinates difference between each sampling point, select the parts with relatively uniform difference, determine the lowest pixel point and the highest pixel point selected, and measure the angle. The calculation formula is:

$$\frac{P\_End - P\_Start}{\theta_Q} = \frac{P\_End - Pixel}{\theta} \quad (2)$$

In formula (2),  $P\_End$  is the highest pixel,  $P\_Start$  is the lowest pixel,  $\theta_Q$  is the camera angle corresponding to the selected lowest pixel and the highest pixel, as the maximum field angle. In the case of a single camera, the angle relationship between them is shown in the following figure (Fig. 5):

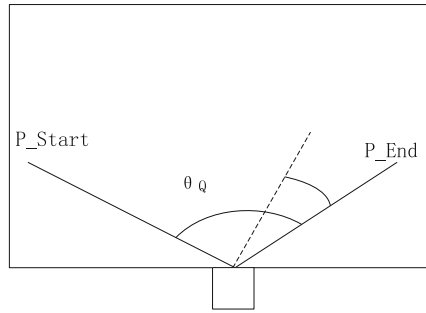

**Fig. 5.** Relationship between angles

After obtaining the angle relationship, the corresponding relationship between the spatial physical coordinates of the sampling point and the pixel coordinates of the image can be established: The horizontal distance between the two cameras is  $L$ , and the width of the delimited area  $W$  is used for projector projection. The angle between the highest pixel of the left camera and the horizontal direction is  $\theta_L$ , and the angle between the lowest pixel of the right camera and the horizontal direction is  $\theta_L$ . According to these two included angles, the positioning analog signal is finally determined.

## 4.2 Database Design

Database is a collection of organized and shareable large amount of data stored in computer for a long time. The data in database is described, organized and stored according to a certain data model, which has the characteristics of permanent storage, organization and shareable [8]. In the database design of this paper, the amount of buoy positioning data that users need should be reasonably stored, and the stored data should have the ability of fast feedback, which can effectively and quickly realize the secondary development of users' data. In the conceptual structure design of the database,

the E-R model is used to represent the data logic. The E-R diagram of the buoy is shown as follows (Fig. 6):

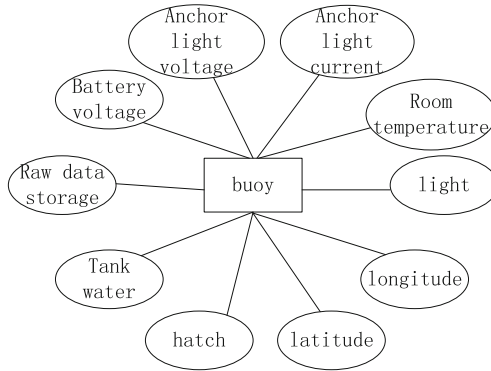

**Fig. 6.** E-R chart of buoy

In conceptual structure design, E-R model is a logical representation of data, which is not constrained by any DBMS and is widely used as a tool of data modeling in database design. The logical structure design of the database is to convert the basic E-R diagram designed in the conceptual structure design stage into the logical structure consistent with the data model supported by the DBMS, to ensure that the basic table structure is reasonable, to reduce data redundancy, and to improve the utilization rate of storage space [9]. This system adopts the classical relational database architecture to determine the number of tables in the database and the relationship between tables. The buoy body information table records the element values related to buoy body safety, with the whole time as the primary key. The details are as follows (Table 2):

**Table 2.** Field description of buoy information table

Field meaning	The field name	The data type	Whether the primary key
The hour of time	IntegralTime	Datetime	Not null
Sampling time	SampleTime	Datetime	Null
Battery voltage	BatteryVoltage	Nvarchar [50]	Null
Anchor light voltage	LightVoltage	Nvarchar [50]	Null
Anchor light current	LightCurrent	Nvarchar [50]	Null
Anchor light current	CabinTempt	Nvarchar [50]	Null
light	Light	Nvarchar [50]	Null
longitude	Longitude	Nvarchar [50]	Null
latitude	Latitude	Nvarchar [50]	Null
hatch	DoorAlarm	Int	Null
Tank water	WaterAlarm	Int	Null
Raw data storage	SaveDate	Int	Null

After getting the E-R diagram and field table, the database can be created. SQL Server 2005 provides us with rich graphical management tools, which facilitates the creation and configuration of database. The specific steps are as follows: (1) First, select the appropriate version of SQL Server database according to the existing laboratory conditions, computer hardware resources and operating system environment. Windows XP is selected as the operating system and SQL Server 2005 is selected as the database version; (2) After the completion of database installation, define the database, name the database inmarsatbuoy, and create the database with graphical method or T-SQL statement; (3) Create all kinds of table spaces to be used – InMarsatATPressure, InMarsatBuoyBody, InMarsatHumidity, Water temper, Wave, Wind, etc. And create tables with graphical methods or T-SQL statements. The workflow of the buoy positioning system based on visual feature recognition is as follows (Fig. 7):

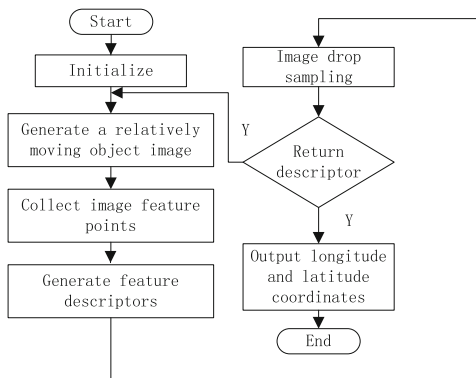

Fig. 7. System work flow chart

So far, the design of buoy positioning system based on visual feature recognition is completed.

## 5 Simulation Test Experiment

In order to verify the effectiveness of the designed system, we need to design simulation experiments, and use the traditional positioning system as a contrast, and analyze the experimental results.

### 5.1 Experimental Environment

The hardware emulator xds560 is selected as the bridge between DSP processing platform and PC to ensure that the simulation results of the system are consistent with the actual operation results. Make full use of the fast characteristics of this hardware

emulator to realize fast code download and online debugging. The system connection using the hardware emulator is as follows (Fig. 8):

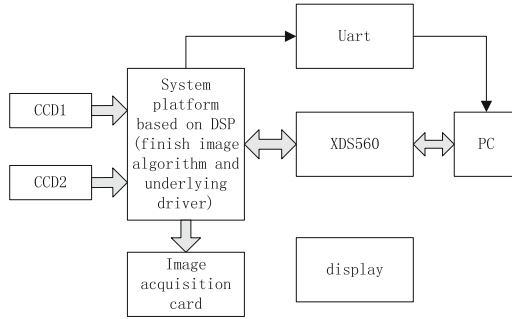

**Fig. 8.** System experiment environment

According to different functions, the experimental system is divided into the following main parts: (1) Feature acquisition: CCD1 and CCD2 represent two cameras respectively, real-time acquisition of images waiting for DSP platform processing. (2) Signal processing part: the DSP used in the experiment is TMS320DM642 digital signal processor of TI company, and the design of software system is completed on SEED-VPM642 development board provided by hezhongda company, in which video coding and decoding equipment and UART communication module have been integrated. TMS320DM642 is the core device of the scheduling management system. It manages the related equipment and runs the finger recognition and positioning algorithm. The experiment was carried out in this experimental environment and the results were analyzed.

**5.2 Experimental Results and Analysis**

Because of the limitation of marine environment (such as the influence of sea breeze and wave), some external conditions and factors cannot be determined, so the method of qualitative analysis cannot be carried out. In addition, because of the combination of qualitative and quantitative experimental methods, it has a subjective effect on the experimental results to some extent, so this experiment will be carried out by quantitative analysis. In the above experimental environment, the original system and the system designed in this paper are compared. The experimental results are shown in the following table (Table 3):

**Table 3.** Experimental result

Location feedback time	The original system latitude and longitude	Latitude and longitude of the system	Latitude and longitude of traditional systems
7:00	120.3 39.1	120.2835 39.0708	122.45 40.64
8:00	120.3 40.9	120.3055 40.8654	121.32 39.72
9:00	120.6 39.0	120.875 39.0282	121.34 40.21
10:00	120.4 39.0	120.3771 39.0146	119.87 30.73
11:00	120.3 39.6	120.3029 39.5894	120.86 40.12
12:00	120.3 39.6	120.3084 39.6027	121.02 39.76
13:00	120.3 39.5	120.3222 39.5259	120.642 40.43

Using the original positioning system and the system designed in this paper, we can receive the longitude and latitude coordinates fed back by the system every hour. When the feedback coordinates are retrieved and analyzed, the longitude and latitude of the original system can only be accurate to one decimal place. The longitude and latitude coordinates of the feedback system designed in this paper can be accurate to four decimal places. It can be seen that the positioning system designed in this paper is more accurate.

## 6 Conclusion

Because the longitude and latitude feedback of traditional positioning system of ocean monitoring buoy is not accurate enough, a positioning system of ocean monitoring buoy based on visual feature recognition is designed. Through the design of hardware and software, the positioning system of ocean monitoring buoy based on visual feature recognition is designed. According to the simulation results, the designed system feedback longitude and latitude coordinates can be accurate to four decimal places, indicating that the designed positioning system longitude and latitude coordinates positioning is more accurate. Especially in the severe weather, the buoy positioning system can monitor the marine hydrological and meteorological parameters in an all-round way, and provide valuable data support for the meteorological research of the marine sector, which has the particularity that other monitoring methods can not replace. Therefore, the design and analysis of the marine buoy positioning system can better promote the progress of marine positioning technology and make contributions to the marine monitoring industry.

## References

1. Zhao, J., Wang, Z., Hui, L., et al.: Design of a marine multi-point water quality monitoring system based on underwater acoustic communication. *J. Dalian Fish. Univ.* **32**(6), 747–752 (2017)
2. Cao, W., Sun, Z., Li, C., et al.: Design and application of data collecting system and data receiving system for water quality monitoring buoy. *J. Trop. Oceanogr.* **37**(5), 1–6 (2018)
3. Kong, W., Yang, Z., Ma, S.: Design of ultra-low power consumption ocean drifting buoy collector based on MSP430. *Mod. Electron. Tech.* **40**(20), 146–149 (2017)
4. Rao, K.-y., Ji, X.-p., Chen, J.-m., et al.: Design and implementation of the low-power management scheme for the Polar Drift-Towing Ocean Profiler. *Mar. Sci.* **41**(9), 27–33 (2017)
5. Wang, S., Tian, Y., Tian, K.: Application of BeiDou satellite navigation system in wave energy self-powered marine Buoy. *GNSS World China* **43**(04), 130–134 (2018)
6. Zhao, T., Qi, J., Ruan, D.-s., et al.: Design of an ocean buoy auto-warning system based on geomagnetic-infrared detection. *J. Ocean Technol.* **36**(5), 19–25 (2017)
7. Zhang, Z., Wu, N., Yu, J.: Design and implementation of underwater acoustic identification system based on feature template matching. *Comput. Digital Eng.* **46**(11), 2274–2278 (2018)
8. Zhang, K., Wang, H., Chen, X.-d.: Visual dispensing system based on automatic recognition of workpieces. *Modular Mach. Tool Autom. Manuf. Tech.* **533**(7), 43–47 (2018)
9. Wan, Q., Yu, H., Wu, D., et al.: Survey of multiple objects tracking based on three-dimensional visual systems. *Comput. Eng. Appl.* **53**(19), 33–39 (2017)