



Design of Corpus Based Comprehensive Ability Evaluation System for College English Teaching

Ying Yu¹ (✉) and Shengzuo Lin²

¹ Panjin Vocational and Technical College, Panjin 124010, China
yuying12012@126.com

² Guangdong Polytechnic of Environmental Protection Engineering, Foshan 528000, China

Abstract. At present, the evaluation accuracy of the comprehensive ability evaluation system of College English teaching is low, and the stability of the evaluation process is poor, resulting in greater risks in the evaluation process. In order to solve the above problems, a new comprehensive ability evaluation system for College English teaching is designed based on corpus, and the hardware and software of the system are optimized. The system hardware mainly designs microprocessor, signal modulator, power module, evaluator, single chip microcomputer and collector. The processor selects sep83 microprocessor and introduces sd63c84 chip. At the same time, en, A1 and A0 are designed as the input ports of the program-controlled amplification circuit of the regulator. The main control chip of the single chip microcomputer is ti7392 and the acquisition is realized through snt5428. By introducing corpus, the software workflow is realized through information collection, quantitative evaluation, designing practical and effective evaluation contents of comprehensive ability of College English teaching, reducing evaluation errors. The experimental results show that the corpus based College English teaching comprehensive ability evaluation system can effectively improve the evaluation stability, reduce the evaluation risk and enhance the accuracy of the evaluation process.

Keywords: Corpus · College English · English teaching · Comprehensive ability · Evaluation system

1 Introduction

With China's development entering a new era, the degree of economic and cultural globalization is deepening. With the support of the national foreign policy, the number and scale of multinational groups and foreign enterprises continue to increase. Therefore, the demand for foreign language talents with strong ability is increasing in China. In recent years, the research on College English has also made many achievements. The state has also issued relevant laws and regulations to support the development of College English in China. At present, China is still in the primary stage of development, has not formed a complete development system, and lacks special laws and regulations

protection. There are many problems such as loose system and lack of educational resources [1, 2].

With the deepening of globalization and more and more frequent exchanges in various fields of society, College English education is very important. For these problems, we should first consider the quality and ability level of English teachers. Teachers are an important driving force to promote the stable development and progress of the industry. How to improve teachers' knowledge, skills and professional quality has attracted the attention of the education sector [3–5].

In order to test and improve English teachers' professional competence, relevant scholars put forward the framework of teachers' technical teaching content knowledge and ability in terms of teachers' teaching skills and knowledge content as early as ten years ago. This paper designs a new college English teaching comprehensive ability evaluation system based on corpus, designs the hardware and software of the system, and verifies the effectiveness of the evaluation system through experiments.

2 Design of College English Teaching Comprehensive Ability Evaluation System

2.1 Microprocessor Design

The processor is the driving device of the system hardware system, which mainly completes the interaction between the system terminal and the control terminal. The microprocessor has stronger performance and higher processing accuracy than the processor. In this paper, SEP83 microprocessor is selected to complete the design of the system. SEP83 microprocessor adopts 1.5V core power supply mode, which can reduce the power consumption of the chip, reduce the load inside the system and improve the running rate of the microprocessor [6]. The chip of this microprocessor is equipped with a special chip management PMC unit. The clock state of the microprocessor chip can be controlled in real time through the unit module, so as to achieve the purpose of low power consumption of the microprocessor [7, 8].

The processor supports 80 GPIOs, and in order to protect the internal data security of the system, the external interrupt function is designed. The device supports the transmission of DMA linked list. 32-bit RISC core is embedded in the microprocessor, which is compatible with 720T ARM. 8 kB instruction data set is used to complete the transmission of control instructions. In order to improve the link efficiency between the processor and other devices, this paper adopts the 16-bit false interface. When the device is started, this interface is also opened at the same time to avoid missing data frames. The internal data transmission protocol of SEP83 microprocessor adopts 10M adaptive Ethernet. The DC/DC circuit diagram of SEP83 microprocessor is shown in Fig. 1:

The microprocessor chip adopts SD63C84 chip newly launched by SD Company. The bus interface unit includes 8-byte input and output interface and 8-bit memory. The control unit includes 32-bit UART interface and 8-bit general register. In addition, the control unit also has a microcontroller, which can control the microprocessor's processing of performance evaluation data, Ensure the integrity and accuracy of the evaluation data [9, 10].

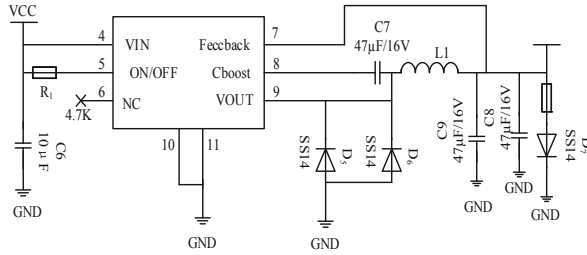

Fig. 1. DC/DC circuit diagram of microprocessor

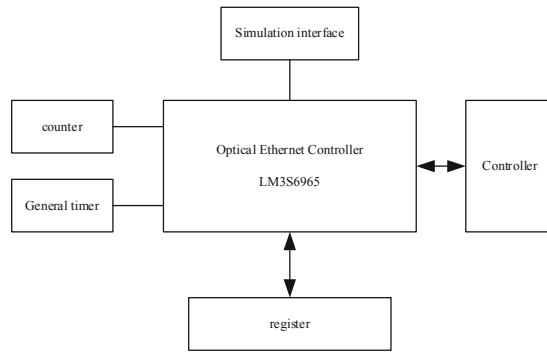

Fig. 2. Microprocessor structure

The microprocessor structure is shown in Fig. 2:

It can be seen from Fig. 2 that the peripheral circuit and power circuit can be used together to facilitate the processing of the system. The microprocessor chip has 10 basic registers to maintain the processing state of the microprocessor. The other six multi-purpose registers can store basic variables. The control unit is not directly connected with the processor bus. It can send read and write requests to the system with an address of 8 bits, Four commands can be controlled and transmitted at the same time. After the control unit controls all processor commands, it can send the interrupt vector to the CPU of the processor [11].

2.2 Design of Signal Modulator

The function of the signal modulator in the system hardware area is to ensure the operation stability of the information security risk assessment system. According to the functional considerations of the system designed in this paper, the signal modulator is designed with 8 regulation modules, which can carry out the interactive processing of 32 channels at the same time. Compared with the traditional controller, the signal modulator has the advantages of not only control, but also communication filtering and amplification process. The program-controlled amplification circuit is the control circuit of the signal regulator. The circuit design en, A1 and A0 are used as the input ports of the program-controlled amplification circuit of the regulator, and the amplification factor is

4 times [12]. The resistance of the signal regulator is divided into four levels, from high to low, which are 8.6Ω , 91Ω , 349Ω and 732Ω respectively. The four different levels of resistance can minimize the error of the signal regulator. The effective range bit of the signal regulator for the information signal is 50–200 kHz. The structural diagram of the specific signal modulator module is shown in Fig. 3:

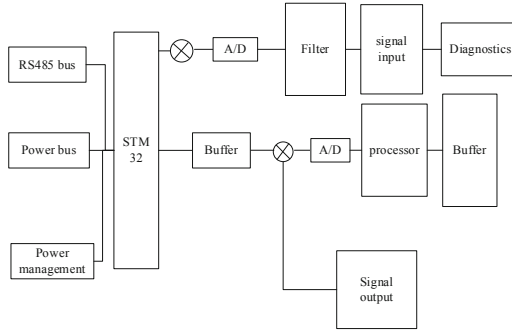

Fig. 3. Structure diagram of modulation module of signal modulator

Taking the broadband I/Q vector modulation signal as an example, the signal modulation is realized by frequency conversion in the transmission link. When the signal system is up and down converted, it is found that the modulation quality and EVM become worse, which are normal phenomena. In the modulation process, the controller error is controlled by different levels of resistance to make it successfully complete the signal modulation.

2.3 Power Module Design

In order to reduce the physical loss of the power block to other devices in the system hardware area, the power module of ub78vb is selected as the power supply device. The limit of the power module is 5 V DC power supply. For the work of small processes of the system, it can also provide 3.3 V or 1.8 V DC power supply. The power module of UB78VB is characterized by adding a 3.8 V filter capacitor on the basis of the traditional power structure, providing the input and output working core for the system and improving the anti-interference of the power module. In order to ensure the safety of the power module, a fuse is added in the device structure. When the power supply continues to supply power or the power circuit current is too large, the device will automatically power off to protect the power circuit board. The control circuit of the power module is shown in Fig. 4:

2.4 Evaluator Design

In order to reduce the complexity of the evaluation process, the device prohibits the low-level state from completing the change of the protection signal. The address bus width of the evaluation board is 19 bits, and the capacity for NOR flash is 2 mbyte.

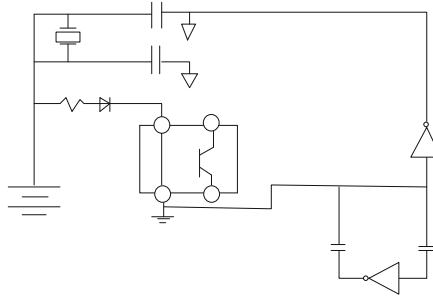

Fig. 4. Power structure circuit diagram of motherboard of power module

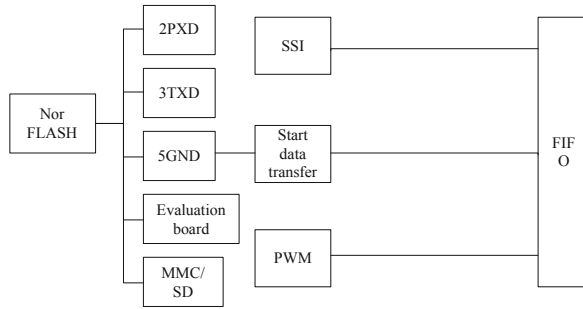

Fig. 5. Structure of evaluator

The structure of the evaluator is shown in Fig. 5:

According to Fig. 5, the evaluation board adopts 2pxd, 3txd and 5GND pins to complete the operations of receiving data, sending data and encrypting data respectively. The evaluation rate of the evaluation board is 11 Mbps. It supports MMC/SD dual card mode. The evaluation board is set with two channels of SSI and PWM, and supports ISO and microwire operating system protocols without random code. The reset voltage of the evaluation board is 3.3 V, the response reset voltage is 2.9 V–3.00 V, and the reset pulse time is 140 s. The operation of the evaluation board adopts 4 m passive crystal oscillator circuit for startup and shutdown control.

SXC765b4 produced by Samsung is selected as the evaluator chip, which is the core of the evaluator, and a microprocessor with efficient processing capacity is added to the periphery to assist the evaluator in processing the performance evaluation result data [13].

Abundant peripherals are set on the periphery of the evaluator. The frequency of one crystal oscillator is 38.728 kHz, and the two crystal oscillators are frequency divided in the chip of the evaluator, so as to improve the working frequency of the evaluator. The circuit diagram of the evaluator is shown in Fig. 6:

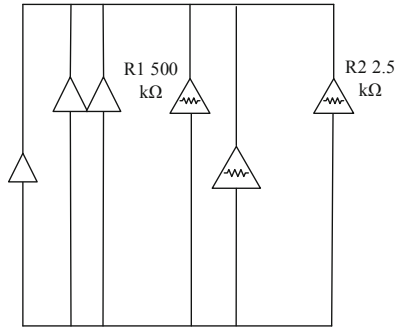

Fig. 6. Circuit diagram of evaluator

Stu5278, one of the peripherals of the evaluator, is a microprocessor with high performance and low power consumption. The working frequency of this microprocessor can reach 380 MHz at most. It adopts a full duplex core. It has simple structure, convenient operation and low power consumption. The periphery of the evaluator is equipped with peripheral circuits. The voltage of the peripheral circuits is controlled at 1.8–3.3 V and the current is 1.2–1.8 A, It is mainly used to assist the power circuit to supply power to the evaluator and other peripherals. When the voltage of the power circuit is unstable or cannot supply power normally, the peripheral circuit can directly supply power to the evaluator and its peripherals, which can effectively improve the voltage utilization and reduce the loss of the power circuit.

2.5 Single Chip Microcomputer Design

The main control chip of the evaluation system designed in this paper is ti7392, which contains 4 kbytes program memory and 64 Kbytes data memory. The structure of single chip microcomputer is shown in Fig. 7:

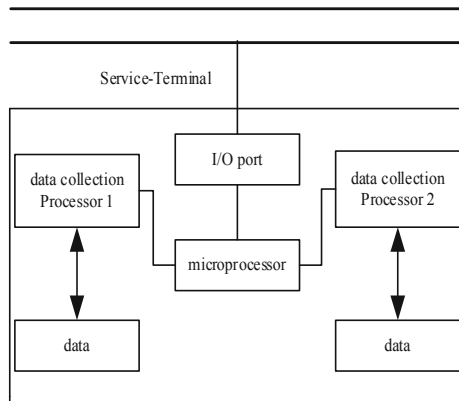

Fig. 7. Structure diagram of single chip microcomputer

It can be seen from Fig. 7 that the single chip microcomputer chip has 15 pins and 4 external and medium ports, which can count the performance data and talent ability data of the human resources management department. In addition, it also has 6 two-way parallel communication ports.

The clock frequency of single chip microcomputer chip is very low, with sleep mode and super power saving mode. I/O port and data memory can be used to wake up the single chip microcomputer. In the power saving mode of single chip microcomputer, the data memory is in shutdown state and stops storage. The working voltage of single chip microcomputer is 1.8–10 V, which can be operated statically, and the working frequency is 0–48 MHz, The size of data storage space is 256×8 bytes, with 12 interrupt sources, Serial uart channel and USB interface. The single chip microcomputer can receive and process the evaluation signal transmitted by the performance evaluation system.

2.6 Collector Design

The collector chip of the evaluation system is snt5428 produced by Samsung, which has strong acquisition capability. The peripheral circuit of the collector does not need to be expanded, which can improve the integration and reliability of the collector and make the data acquisition operation of the collector relatively simple.

The collector has a power circuit to prevent the USB interface from being powered due to accidents. It can collect resource data and evaluation data in the human resources performance evaluation system. The chip pin needs to be connected with an 8Ω resistance. The collector is also equipped with a reset button to download and debug the evaluation system. The USB connecting line between the timer and the collector is a double-layer protection line, It can effectively protect the collector and other accessories from damage and interference.

The collector circuit diagram is shown in Fig. 8:

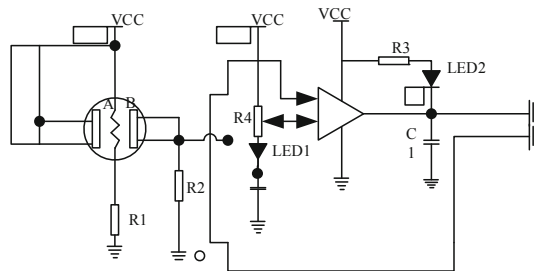

Fig. 8. Collector circuit diagram

3 Software Design of College English Teaching Comprehensive Ability Evaluation System Based on Corpus

College English teaching comprehensive ability evaluation system mainly calls a quantitative evaluation model jointly constructed by corpus to analyze abstract meaning

and judge College English teaching comprehensive ability. The design concept of the evaluation model is shown in Fig. 9:

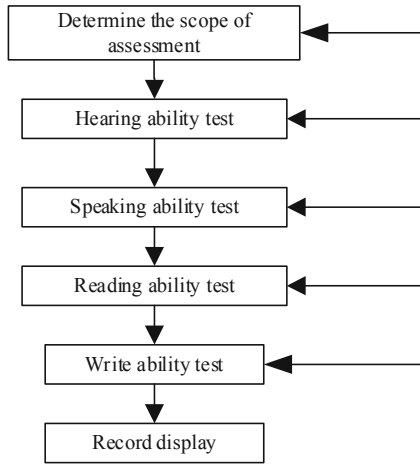

Fig. 9. Structure diagram of evaluation model

The set of evaluation factors is established by using the expected set. The variables stored in the set are the decisive variables of the model to analyze the elements to be evaluated. Establish an evaluation weight set, and the weight calculation formula is shown in formula (1):

$$b_i = \frac{1}{k} \sum_{j=1}^n b_{ij} + \partial a_{ij} \tag{1}$$

where, b_i represents the weight calculation result; b_{ij} represents the set of evaluation factors; k represents the serial number of the evaluation expert; a_{ij} represents the weight set; ∂ is the normalization coefficient.

According to the division specification of evaluation results, the mapping relationship and evaluation membership matrix are constructed, and the evaluation set of evaluation model is established. In order to shorten the error between model evaluation levels, the membership matrix is evaluated. The evaluation fuzzy membership matrix of data is shown in formula (2):

$$s = \left\{ \begin{matrix} S_{11} & S_{12} & \dots & S_{M1} \\ S_{21} & S_{22} & \dots & S_{2m} \\ \vdots & \vdots & \ddots & \vdots \\ S_{m1} & S_{m2} & \dots & S_{mm} \end{matrix} \right\} * \frac{S_r}{B} \tag{2}$$

where, S_{ij} represents the membership vector; S_r represents risk factors; B represents the weight allocation set.

After the successful construction of the evaluation model, the corpus is used to pre-process the data to be evaluated, input the data into the evaluation model for calculation, and the model outputs the evaluation vector results for many times. After weighted average calculation, the final comprehensive ability safety evaluation result of College English teaching is obtained, which can be the evaluation of comprehensive ability.

The software flow of corpus based College English teaching comprehensive ability evaluation system is shown in Fig. 10:

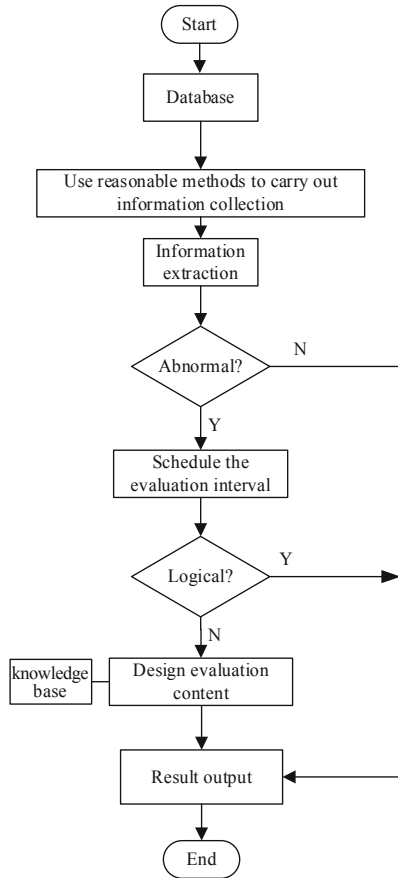

Fig. 10. System software implementation process

According to Fig. 10, the corpus based College English teaching comprehensive ability evaluation system software can be divided into several steps.

Step 1: carry out information collection in a reasonable way. The designed collector is used to collect a large amount of information. After the last performance evaluation, the information will be collected by the system. The collected results will be modulated by the signal modulator and stored in the mobile intelligent terminal. After the first collection, analyze the College English teaching performance, determine the employee

performance through the evaluation of others, and evaluate the employee performance after the evaluation is synthesized. Before the evaluation meeting, Screening the information related to the performance of colleges and universities to ensure the fairness and objectivity of information.

Step 2: scientifically arrange the time interval of comprehensive ability evaluation of College English teaching. The time interval of College English teaching comprehensive ability evaluation will affect the results of College English teaching comprehensive ability evaluation. When arranging the time interval of College English teaching comprehensive ability evaluation, we should ensure the rationality of the arrangement.

Step 3: design practical and effective evaluation contents of comprehensive ability of College English teaching. The content of College English teaching comprehensive ability evaluation should be designed on the basis of fairness, impartiality and science. The evaluation content should be timely. The evaluation content should be adjusted according to the nature of teachers' work. The last evaluation results can not be used. The evaluation results should be consistent with teachers' comprehensive performance in a period of time.

Step 4: reduce the evaluation error of College English teaching comprehensive ability. In the evaluation of College English teaching comprehensive ability, although the errors caused by external factors can not be avoided, certain methods can be adopted to avoid the errors as far as possible. The methods to reduce the errors include: unified training for evaluators to ensure the fairness and impartiality of the evaluation work, and the evaluation standards of evaluators should be unified and coordinated, The assessment focuses on work ability and practical operation.

Step 5: feedback the evaluation results and strengthen communication. After the comprehensive ability evaluation of College English teaching is completed, the evaluation results shall be fed back to the teachers to understand their own evaluation results. If there are problems, they shall communicate with the evaluators in time to solve the problems in the evaluation process and discuss the solutions together.

4 Experimental Study

In order to verify the effectiveness and stability of the corpus based College English teaching comprehensive ability evaluation system designed in this paper, the traditional evaluation system is compared with this evaluation system.

The experiment refers to the normal evaluation criteria, analyzes the distribution rate, establishes the judgment matrix, establishes the evaluation result matrix according to the evaluation index weight, normalizes the evaluation result matrix according to the fuzzy evaluation method, and integrates the above process according to the 9 importance levels and their assignment given by Saaty. The score of the evaluation result is 80 points, while the score of the evaluation result obtained by the traditional evaluation system is 75 points, indicating that the evaluation effect of the evaluation system designed in this paper is better. The experimental results of evaluating process accuracy are shown in Fig. 11:

It can be seen from Fig. 11 that with the increase of time, the traditional evaluation system and the evaluation system studied in this paper extend towards two different

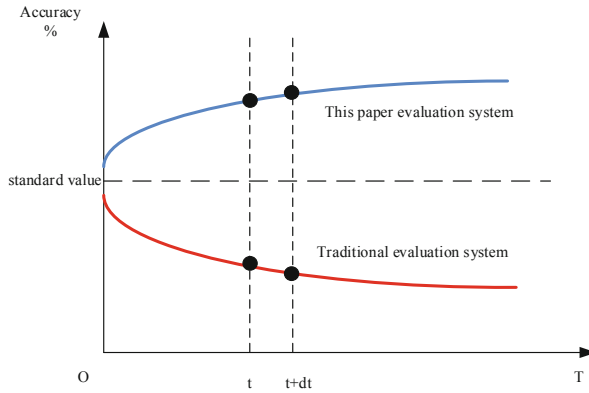

Fig. 11. Experimental results of evaluating process accuracy

trends. The evaluation results of the evaluation system provided in this paper become more and more accurate, while the evaluation results of the traditional evaluation system become more and more inaccurate. This is mainly because the traditional evaluation system integrates too many subjective factors, and with the increase of time, Subjective factors increasingly affect the accuracy, and the performance evaluation system studied in this paper has strong objectivity. Therefore, with the increase of time, the evaluation results become more and more accurate. It can be seen that the traditional human resources performance evaluation system has few evaluation schemes and inaccurate evaluation results, unscientific evaluation methods and low reliability and efficiency of evaluation results. The experimental results of evaluating system stability are shown in Table 1:

Table 1. Experimental results of evaluating system stability

Evaluation times/time	Evaluate system stability %	
	Traditional evaluation system	Paper evaluation system
1	70.25	97.25
2	75.22	98.25
3	74.28	99.44
4	76.34	97.83
5	74.22	98.96
6	73.86	99.84
7	74.85	98.25
8	75.96	97.86
9	78.51	98.69
10	76.15	97.39

According to Table 1, the evaluation system proposed in this paper has better stability in the evaluation process. The evaluation system designed in this paper combines the corpus with the human resources evaluation system, optimizes the means of evaluation, makes the human resources performance evaluation more intelligent and scientific, and makes the evaluation effect more obvious, so that the stability, reliability and feasibility of the comprehensive ability evaluation system of College English teaching are higher, which can be proved by the experimental data, The College English teaching comprehensive ability evaluation system designed in this paper is better than the traditional evaluation system, has higher stability and feasibility, the evaluation results are more accurate, fair and fair, and the evaluation means are more scientific.

The time spent in the evaluation process is shown in Fig. 12:

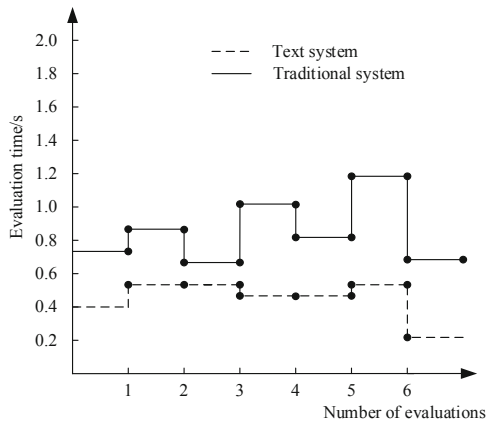

Fig. 12. Experimental results of time spent in the evaluation process

It can be seen from Fig. 12 that due to the influence of external factors, the time spent in the evaluation process will change irregularly, but the system will accumulate experience in each evaluation. When the number of evaluations reaches more than 6, the evaluation time will be greatly shortened. Although it is difficult to determine the time spent in the evaluation process, the evaluation system designed in this paper always takes less time than the traditional system. The evaluation time of the traditional system fluctuates between 0.6 s and 1.2 s. The evaluation time of the system in this paper fluctuates between 0.2 s and 0.6 s. The evaluation time is very short, which ensures the real-time performance of the evaluation.

The evaluation system studied in this paper displays the work results in a short time to effectively ensure the work effect. Once it is found that the anti-interference performance of the equipment is poor, the system will automatically put forward the solution strategy. It is an efficient and accurate evaluation system.

5 Conclusion

Efficient English education is the future development direction of higher English education in China. At present, the development of efficient English Teaching in China still

faces many difficulties and challenges. Therefore, this paper designs a corpus based College English teaching comprehensive ability evaluation system, evaluates the existing college English teaching comprehensive ability through the optimization of hardware and software, and provides reference for formulating English teaching strategies, which can play a certain guiding role in the training and development of College English teachers in China, It can provide reference for the development and training plan of English education for relevant educational institutions and promote the development and progress of English education in Colleges and universities in China.

References

1. Wu, C.C., Yang, C.Y., Hwang, M.S., et al.: The design and application of a web-based teacher evaluation system for STEM education. *Int. J. Electr. Eng. Educ.*, 002072091985278 (2019)
2. Ulusoy, A.J., Pecci, F., Stoianov, I.: An MINLP-based approach for the design-for-control of resilient water supply systems. *IEEE Syst. J.* **PP**(99), 1–12 (2020)
3. Wu, X.L., Liu, L.X., Yang, L.Y., et al.: Comprehensive rehabilitation in a patient with corpus callosum syndrome after traumatic brain injury: case report. *Medicine* **99**(28), e21218 (2020)
4. Damme, P., Ungethuem, A., Hildebrandt, J., et al.: From a comprehensive experimental survey to a cost-based selection strategy for lightweight integer compression algorithms. *ACM Trans. Database Syst.* **44**(3), 1–46 (2019)
5. Ni, Q., Zhang, L., Zhang, B., et al.: Interdisciplinary method for assessing students' ability based on STEM projects. *Int. J. Eng. Educ.* **35**(2), 698–709 (2019)
6. Huang, J.: An Internet of Things evaluation algorithm for quality assessment of computer-based teaching. *Mob. Inf. Syst.* **2021**(13), 1–10 (2021)
7. Blondet, G., Le Duigou, J., Boudaoud, N.: A knowledge-based system for numerical design of experiments processes in mechanical engineering. *Expert Syst. Appl.* **122**, 289–302 (2019)
8. Cheng, F., Gao, Y., Guo, X., et al.: Fabrication of nanostructured skutterudite-based thermoelectric module and design of a maximum power point tracking system for the thermoelectric pile. *IEEE Sens. J.* **PP**(14), 1 (2019)
9. Liu, S., Fu, W., He, L., Zhou, J., Ma, M.: Distribution of primary additional errors in fractal encoding method. *Multimedia Tools Appl.* **76**(4), 5787–5802 (2014). <https://doi.org/10.1007/s11042-014-2408-1>
10. Chen, H., Zhou, J.: Effects of sodium selenite on oxidative damage in the liver, kidney and brain in a selenite cataract rat model. *Biol. Trace Elem. Res.* **197**(2), 1–11 (2020)
11. Liu, S., Pan, Z., Cheng, X.: A novel fast fractal image compression method based on distance clustering in high dimensional sphere surface. *Fractals* **25**(4), 1740004 (2017)
12. Xi, T.: Design of English diagnostic practice sentence repetition recognition system based on matching tree and edge computing. *Wirel. Commun. Mob. Comput.* **2021**(3), 1–8 (2021)
13. Liu, S., Liu, G., Zhou, H.: A robust parallel object tracking method for illumination variations. *Mob. Netw. Appl.* **24**(1), 5–17 (2018). <https://doi.org/10.1007/s11036-018-1134-8>