



# On-line Monitoring Method of Power Transformer Insulation Fault Based on Bayesian Network

Ye-hui Chen<sup>1(✉)</sup>, Ling-long Tan, and Ying-hua Liu<sup>2</sup>

<sup>1</sup> Electronic Communications Engineering College, Anhui Xinhua University, Hefei, China

chenyh36900@163.com

<sup>2</sup> Wuhan Institute of Design and Sciences, Wuhan, Hubei, China

**Abstract.** Power transformer insulation fault location is the key to improve the stability of power transformer. A Bayesian network based on power transformer insulation fault on-line monitoring method is proposed. The Bayesian network characteristic decomposition model is used to detect the insulation fault of power transformer, the high-resolution spectrum characteristic quantity of insulation fault of power transformer is extracted, the load balance analysis is carried out according to the output voltage and load difference of power transformer, the Bayesian network detection model of insulation fault of power transformer is constructed. Combined with PCI integrated information processor and relay transmission node network topology model, the on-line monitoring system design of power transformer insulation failure is realized. The simulation results show that the fault location of power transformer insulation is accurate and the visual resolution of fault is strong.

**Keywords:** Bayesian network · Power transformer · Insulation failure · On-line monitoring

## 1 Introduction

The insulation fault of power transformer is the main fault category of power transformer. In power transformer, due to the access of large-scale power grid and electrical components [1], it is easy to produce insulation fault of power transformer. It is of great significance to locate and identify insulation fault of power transformer, analyze the types of insulation fault of power transformer, improve the ability of type identification and characteristic analysis of insulation fault of power transformer, and study the on-line monitoring method of insulation fault of power transformer [2].

At present, some research results have been made in the identification and positioning of the insulation fault of the power transformer, the on-line monitoring of the insulation fault of the power transformer is based on the fault data mining and the adaptive feature extraction [3], the invention relates to an on-line monitoring of the insulation fault of a power transformer by combining the characteristics of the insulation inversion characteristic and the spectral characteristic extraction of the power transformer, wherein the online monitoring method of the insulation fault of the power

transformer based on the frequency spectrum analysis and the correlation detection is proposed in the document [4], The sensor information distribution model of the insulation fault of the power transformer is constructed, the correlation characteristic analysis and the power transmission load detection method are adopted to realize on-line monitoring of the insulation fault of the power transformer, but the accuracy of this method is low; In the reference paper [5], a fast detection algorithm for the insulation fault of the power transformer based on the link forwarding control is proposed, the on-line monitoring model of the insulation fault of the power transformer is constructed by adopting the link balance control model, and the self-adaptive feature extraction and the fuzzy association mining method are adopted, The on-line monitoring of the fault is realized, but the accuracy of this method is low, which leads to the poor accuracy of on-line fault monitoring. In view of the above problems, an on-line monitoring method for insulation fault of power transformer based on Bayesian network is presented in this paper. The Bayesian network detection model of an insulation fault of a power transformer is built, the convergence judgment in the on-line monitoring of the insulation fault of the power transformer is carry out by adopting an adaptive machine follow-up learning method, and the hardware design of the system is carried out, and finally, the simulation experiment analysis is carried out, and the fault positioning capability of the design system is shown.

## 2 Fault Information Detection and Feature Extraction

### 2.1 Insulation Fault Information Collection of Power Transformer

In order to realize the on-line monitoring design of power transformer insulation fault, it is necessary to collect the insulation fault sample information of power transformer, combine the multi-dimensional sensor networking method to carry on the on-line monitoring design of power transformer insulation fault. The abnormal information of power transformer insulation section is extracted by infrared spectrum technology, and cluster the abnormal information  $k$  of power transformer insulation segment [6]. The relationship between the fault signal sample set  $\Psi(\omega)$  of the insulation fault distribution of power transformer and the distribution phase of the fault node  $c_k$  is as follows:

$$c_k = (-j)^k \Psi(\omega) \quad (1)$$

where  $j$  is the number of failed nodes. Let the sample set sequence  $x(n)$  of insulation fault feature distribution of power transformer be  $k$ -order Gaussian stationary process with zero mean value, construct a depth network with multiple hidden layers for adaptive learning, and obtain the expression of characteristic expression function  $N$  of fault data. By adjusting the parameters, the output steepness parameter  $C_N(r)$  is as follows:

$$C_N(r) = \frac{2}{N(N-1)} \sum_{i=1}^N \sum_{j=i+1}^N c_k(r - \|x(n)\|) \quad (2)$$

where  $r$  is the parameter after fault feature extraction. An under-damped oscillation detection method is adopted to carry out the initial voltage of the insulation of the power transformer and the under-damped oscillation component detection [7]. Capturing the thick-tail data, constructing a power transformer insulation fault signal vector  $s(t) = [s_1(t), s_2(t), \dots, s_q(t)]^T$  and a noise vector  $n(t)$ , and the two are independent of each other, so that the high-power jump characteristic quantity of the power transformer insulation fault data sample  $i$  and the  $u$ -type fault can be expressed as:

$$f_j(u_j, s) = n(t) \sum_{j=1}^c \{ u_j^2 \left[ \sum_{i=1}^m [C_N(r)(r_{ij} - s_i)]^2 \right]^{\alpha/2} \} \quad (3)$$

In the polar coordinate space composed of voltage and phase angle, according to the matching result of the transferred balance power, the sample information collection of the insulation fault of the power transformer is carried out in combination with the Boost-MMDCT voltage amplitude detection method, at this time [8], the balance power to be transferred is  $\{\lambda_i: 1 \leq i \leq S\}$  and in the current flow path diagram, the Raman spectrum characteristic detection of the insulation fault of the power transformer is carried out, a phase flow characteristic distribution model is constructed by adopting the same modulation signal, the conducting state of each switch of the power transformer is controlled, the micro-load is polymerized, and the output load  $y_{ij}$  is as follows:

$$y_{ij} = T \operatorname{sgn}(u - 0.5) \left[ \left( 1 + \frac{1}{T} \right)^{|2u-1|} - 1 \right] \quad (4)$$

where  $T$  is the fault identification time. The random variables extracted from the distribution of load jump are reorganized in high dimensional phase space for the extracted bearing fault characteristics [9]. The sampled insulation fault data of power transformer are extracted by Raman spectrum detection method, and the weight of insulation fault distribution node  $\tilde{x}_k^i (k > 2)$  of power transformer  $\tilde{w}_k^i$  is calculated as:

$$\tilde{w}_k^i = \tilde{w}_{k-1}^i \frac{f_j(u_j, s)(\tilde{x}_k^i / \tilde{x}_{k-1}^i)}{y_{ij}} \quad (5)$$

The Bayesian network feature decomposition model is used to detect the insulation fault characteristics of power transformers, and the high resolution spectrum characteristics of power transformer insulation faults are extracted, and the load balancing analysis is carried out according to the output voltage and load difference of power transformers.

## 2.2 Fault Feature Extraction

According to the output voltage  $e^{(j/2) \cot a.m^2 \Delta u^2}$  and the load difference  $e^{-j \cdot \frac{\text{sgn}(\sin z) \cdot 2\pi m}{M}}$  of the power transformer, and obtaining the characteristic coefficient  $X_\alpha(m)$  of the output Raman spectrum of the insulation detection output of the power transformer as follows:

$$X_\alpha(m) = \tilde{w}_k^i \cdot e^{(j/2) \cot a.m^2 \Delta u^2} \times \sum_{j=0}^{N-1} e^{(j/2) \cot a.m^2 \Delta u^2} e^{-j \cdot \frac{\text{sgn}(\sin z) \cdot 2\pi m}{M}} \quad (6)$$

The statistical feature quantity  $A_i$  of the extracted fault sample data of power transformer insulators is reconstructed from the input data. The reconstructed input data are analyzed by regression analysis of Raman spectrum data. The clustering output of Raman spectral characteristic data  $B_i$  of power transformer insulation faults is obtained by using fuzzy C-means clustering analysis method. The optimal decision-making cost function  $\Delta M'_{ij}$  for the sample detection of the insulation failure of the power transformer is as follows:

$$\Delta M'_{ij} = X_\alpha(m)(B_i - A_i) \quad (7)$$

The characteristics of the input data and the analysis of the correlation of the insulation fault of the power transformer are analyzed, and the self-adaptive machine tracking learning and the sample clustering detection are carried out [10].

## 3 On-line Monitoring of Insulation Fault of Power Transformer

### 3.1 Analysis of the Characteristics of the High-Resolution Spectrum of the Insulation Fault of the Power Transformer

On the basis of constructing the above insulation fault information acquisition model of power transformer, the high resolution spectrum feature extraction and fault on-line monitoring system of power transformer insulation fault are carried out [11]. In this paper, an on-line monitoring method of power transformer insulation fault based on Bayesian network is proposed, and the power transformer insulation fault feature detection is carried out by using Bayesian network feature decomposition model. Using Bayesian network for insulation fault detection of power transformer can accurately identify and locate the fault location and reduce the occurrence of failure rate. The power distortion caused by the sudden change of insulation fault output of  $s(t)$ , power transformer is obtained. The high resolution spectrum detection of insulation fault samples of power transformer is carried out by using fuzzy association rule mining

method. Therefore, the standard depth feedforward network is used to detect the overvoltage characteristics at the end of the inverter. The output is as follows:

$$s_i(t) = u_i(t) \cos[2\pi f_0 t + \varphi_i(t)] \quad (i = 1, 2, \dots, d) \quad (8)$$

where  $f_0$  is the initial value of detection. The insulation voltage response and overvoltage of  $u_i(t)$  and  $\varphi_i(t)$  transformers are respectively. According to the output voltage and load difference of power transformer, the load balancing analysis is carried out, and the fault discrimination of power transformer insulation is carried out according to the structural similarity characteristics [12]. The real signal model and envelope expression of power transformer insulation channel transmission are given.

$$y(t) = u(s(\Delta M'_{ij})) \exp(j\omega_c s(t - \tau)) \quad (9)$$

In the formula,  $s(t - \tau)$  is a characteristic decomposition coefficient,  $\omega_c$  is a line resistance, a node voltage method is adopted to carry out time domain analysis of the insulation fault data of the power transformer.

The method comprises the following steps of: outputting the expected value and standard deviation value of the statistical characteristic sequence prediction of the insulation fault of the power transformer, carrying out on-line monitoring of the insulation fault of the power transformer in each neuron model, and adopting a multi-layer hidden layer step-by-step detection method to obtain the time-frequency component characteristic as follows:

$$\hat{f}_i(n) = \frac{1}{2\pi} \sum_{i=0}^p in_r(k)n_i(k)^{i-1} \quad (10)$$

If the real part  $n_r(k)$  and the imaginary part  $n_i(k)$  of the insulation fault feature of the power transformer are independent color noise respectively, the high dimensional space-time data are visually analyzed in the low dimensional space. The statistical feature components of the insulation fault sample data of the power transformer are obtained by introducing the convolution neural network into the  $\{R_j : 1 \leq j \leq L\}$ , to extract the Oman spectral features of the insulation fault of the power transformer [13].

### 3.2 Automatic Output of Insulation Fault of Power Transformer

The Bayesian network detection model of insulation fault of power transformer is constructed, and the convergence judgment of on-line monitoring of insulation fault of power transformer is carried out by using adaptive machine tracking learning method [14]. The probability of different frequency of high resolution spectrum of insulation fault of power transformer is counted. If it is recorded as  $sup^t(D)$ , the dimension

reduction of high dimensional space-time fault state samples is carried out, and the vector distribution of each sample column is satisfied.

$$\sum_{i=minsup}^{num^t(D)} sup^t(D) > \delta \tag{11}$$

wherein,  $num^t(D)$  is the visualization result after dimension reduction, the sample statistics  $P$  of insulation fault of power transformer is carried out in time window  $t$ , and the probability distribution of each sample column vector is calculated. For the calculation of  $sup^t(D)$ , the convolution operation is used for fuzzy partition, and the regularization output is obtained as follows:

$$P_{ij}^t = \begin{cases} P_{i-1,j-1}^t \times p_i + P_{i-1,j}^t \times (1 - p_i), & v_i = t \\ P_{i-1,j}^t, & v_i \neq t \end{cases} \tag{12}$$

The fuzzy dispatching set function of the insulation fault of the power transformer obtained in the training of the depth network is expressed as follows:

$$N_i(t) = \{j : \|x_j(t) - x_i(t)\| < R_d^i; l_i(t) < l_j(t)\} \tag{13}$$

wherein,  $x_j(t)$  represents the classification information entropy in the insulation fault feature data set  $D$  of power transformer, describes the sample subset of insulation fault characteristics of power transformer in the  $l_j$  clustering center, SF represents the sample set learned by the generation in the process of classification of insulation fault characteristic data of power transformer, and constructs the Bayesian network detection model of insulation fault of power transformer. The adaptive machine tracking learning method is used to judge the convergence of on-line monitoring of insulation fault of power transformer, and the related characteristics of fault are obtained as:  $FP(X_{ij}, P_{ij}, (sup^{k1}(D), \dots, sup^{kf}(D)), (T_{k1}, \dots T_{kj}))$ , carries out on-line monitoring of insulation fault of power transformer according to the distribution of load difference characteristics, and obtains that the learning iteration of insulation fault location  $x_O^i$  of power transformer is as follows:

$$x_O^i = x_t^i + KN_i(t)(x_j^i - x_t^i) \tag{14}$$

wherein,  $K = 1/\|x_L^i - x_S^i\|$  according to the analysis, the high-resolution frequency spectrum characteristic quantity of the insulation fault of the power transformer is extracted [15], and the fault location is carried out according to the output voltage and the load difference of the power transformer, and the realization flow of the design system is obtained as shown in Fig. 1.

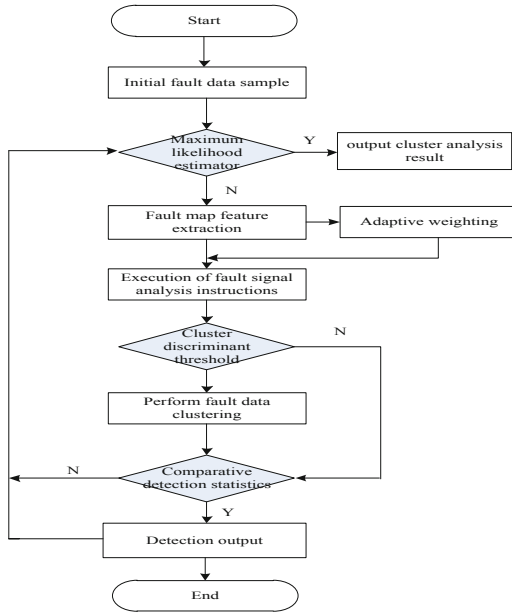

Fig. 1. Fault on-line monitoring implementation process.

#### 4 Simulation Experiment and Result Analysis

On the basis of constructing the insulation fault location algorithm of power transformer based on Bayesian network, the positioning system design and simulation experiment are carried out. The experimental environment is: Using MATLAB simulation tool, Microsoft Windows XP operating system, Intel (R) Celeron (R) 2.6 GHz processor, 24 GB memory. Combined with PCI integrated information processor and relay transmission node network topology model, the on-line monitoring system of power transformer insulation fault is designed. Figure 2 is an on-line monitoring system for transformer insulation fault.



**Fig. 2.** On line monitoring system of transformer insulation fault

According to the above experimental environment, a total of 5000 fault samples, 2000 training samples and 3000 test samples were collected by the on-line monitoring system of power transformer insulation fault. The equivalent circuit model of on-line monitoring of power transformer insulation fault is shown in Fig. 3.

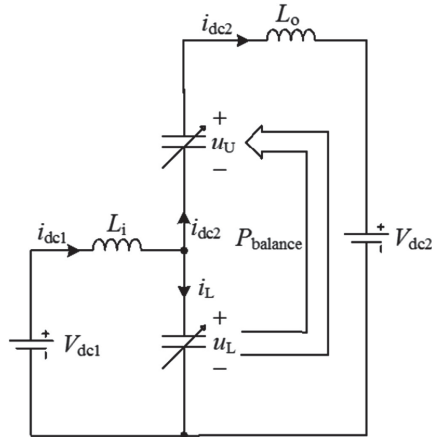

**Fig. 3.** Equivalent circuit model

In the equivalent circuit model shown in Fig. 3, the variable ratio of DC transformer is set to 0.23, the transmission power of converter is 2300 kW, and the average input voltage of upper and lower bridge arm is 200. The topological structure of fault location system is obtained as shown in Fig. 4.

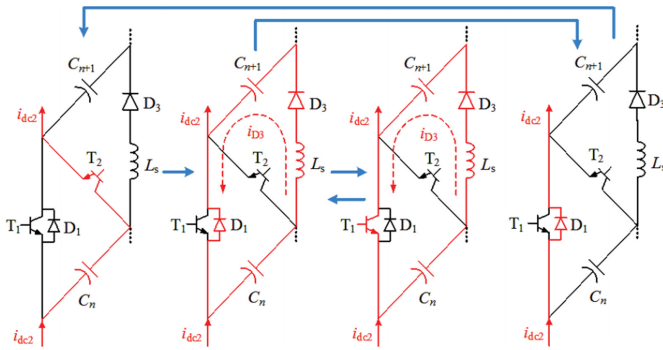

Fig. 4. Topology structure of the fault location system

According to the above system design, the fault location efficiency is tested, and the simulation results of fault location detection are shown in Fig. 5.

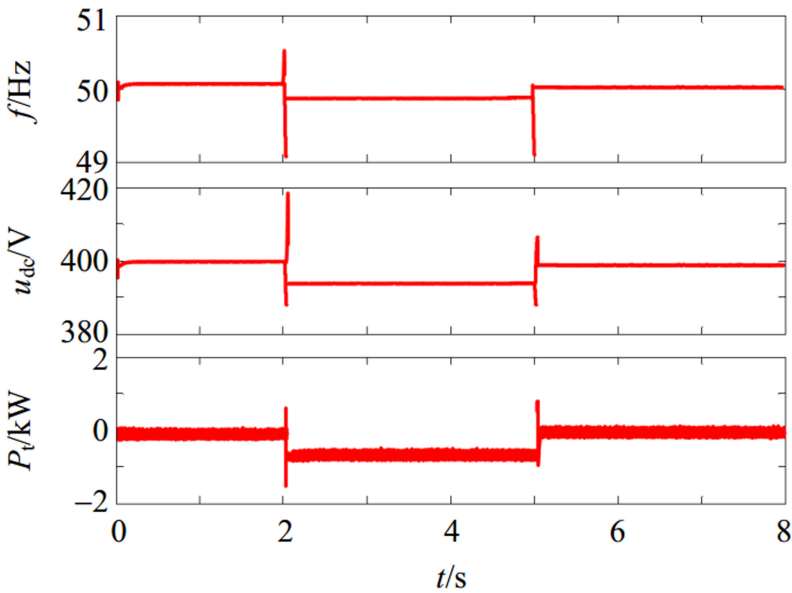
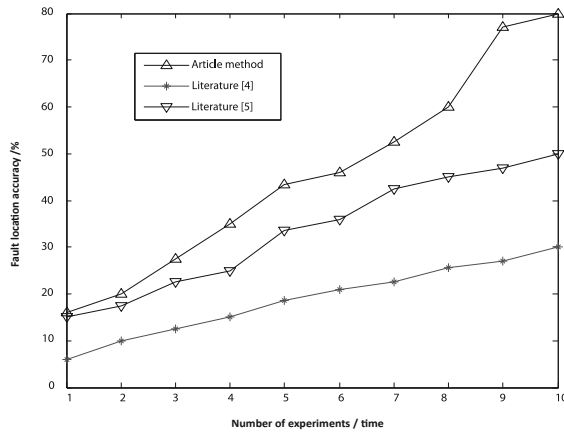

Fig. 5. Simulation results of high resolution spectrum for fault location detection

The analysis of Fig. 5 shows that the insulation fault location detection of power transformer can be effectively realized by using this method, and the accuracy of detection is high, and the peak value of high resolution spectrum is the fault location.

In order to further verify the effectiveness of the method in this paper, the accuracy of insulation fault location of power transformer in this method, literature [4] method

and literature [5] method are compared and analyzed, and the comparison results are shown in Fig. 6.



**Fig. 6.** Comparison results of fault location accuracy

According to Fig. 6, with the increase of the number of experiments, the insulation fault location accuracy of the power transformer in this method can reach up to 80%, while the insulation fault location accuracy of the power transformer in literature [4] and literature [5] is only 30% and 50%. The insulation fault location accuracy of the power transformer in this method is higher than that in literature [4] and literature [5], indicating that this method can accurately monitor the insulation fault of power transformer on line.

## 5 Conclusions

In this paper, an on-line monitoring method of insulation fault of power transformer based on Bayesian network is proposed. Based on the feature analysis of transformer insulation fault in power system, combined with large-scale fault feature data mining and clustering analysis method, the insulation fault discrimination of power transformer is realized, and the classification and identification ability of power transformer insulation fault is improved. The underdamped oscillation detection method is used to detect the initial voltage and underdamped oscillation component of power transformer insulation, the information is reconstructed from the input data, the Bayesian network detection model of power transformer insulation fault is constructed, and the convergence judgment in on-line monitoring of power transformer insulation fault is carried out by using adaptive machine tracking learning method. On-line monitoring of insulation fault of power transformer is carried out according to the distribution of load difference characteristics. It is found that the accuracy and automaticity of this method for insulation fault location of power transformer are high. And has a high power

transformer insulation fault on-line monitoring effect. The research on the insulation fault diagnosis of power transformer has attracted much attention of researchers. In the future, the insulation state evaluation system of power transformer will be established, and the classification will be carried out to improve the on-line monitoring of the insulation fault of power transformer, further improve the intelligent diagnosis technology of transformer fault, and provide a new method for the condition based maintenance of transformer.

## 6 Fund Projects

The Key Research Project of High Education Natural Science of Anhui Province (NO. KJ2016A618).

The Key Research Project of High Education Natural Science of Anhui Xinhua University (NO. KJ2017zr001).

## References

1. Ma, M., Wang, J., Wang, Z., Li, P., Xiong, L.: Transient stability analysis of the global phase portraits in multi-machine system. *Proc. CSEE* **39**(15), 4385–4394 (2019)
2. Wei, S., Yang, M., Han, X., et al.: Online identification for transient angle stability based on MLE index of phase trajectory. *Autom. Electr. Power Syst.* **41**(16), 71–79 (2017)
3. Zhou, Y., Wu, J., Yu, Z., et al.: Power system transient stability assessment based on cluster features of rotor angle trajectories. *Power Syst. Technol.* **40**(5), 1482–1487 (2016)
4. Martínez, Y.P., Vidal, C.: Classification of global phase portraits and bifurcation diagrams of Hamiltonian systems with rational potential. *J. Differ. Equ.* **261**(11), 5923–5948 (2016)
5. Wang, T., Chiang, H.D.: On the number of unstable equilibrium points on spatially-periodic stability boundary. *IEEE Trans. Autom. Control* **61**(9), 2553–2558 (2016)
6. Meng, H., Xu, H., Song, X.: Transformer fault diagnosis based on attribute reduction of rough set and SVM. *Nanjing Hangkong Hangtian Daxue Xuebao/J. Nanjing Univ. Aeronaut. Astronaut.* **49**(4), 504–510 (2017)
7. Arani, M.F.M., Mohamed, Y.A.R.I.: Analysis and performance enhancement of vector-controlled VSC in HVDC links connected to very weak grids. *IEEE Trans. Power Syst.* **32**(1), 684–693 (2017)
8. Zhang, H., Chen, W.: Tungsten oxide (WO<sub>3</sub>) micro balls composed of curly nanosheets for transformer fault gas diagnosis. *J. Nanoelectron. Optoelectron.* **12**(12), 1305–1308 (2017)
9. Guo, C., Liu, W., Zhao, C., Ni, X.: Small-signal dynamics and control parameters optimization of hybrid multi-infeed HVDC system. *Int. J. Electr. Power Energy Syst.* **98**, 409–418 (2018)
10. Ni, X., Gole, A.M., Zhao, C., Guo, C., et al.: An improved measure of AC system strength for performance analysis of multi-infeed HVDC systems including VSC and LCC converters. *IEEE Trans. Power Delivery* **33**(1), 169–178 (2018)
11. Sreewirote, B., Ngaopitakkul, A.: Analysis on behaviour of wavelet coefficient during fault occurrence in transformer. *IOP Conf. Ser. Earth Environ. Sci.* **127**(1), 012008 (2018)
12. Lim, K., Bastawrous, H.A., Duong, V.H., et al.: Fading Kalman filter-based real-time state of charge estimation in LiFePO<sub>4</sub>, battery-powered electric vehicles. *Appl. Energy* **169**, 40–48 (2016)

13. Di, B., Zhou, R., Dong, Z.N.: Cooperative localization and tracking of multiple targets with the communication-aware unmanned aerial vehicle system. *Control Dec.* **31**(04), 616–622 (2016)
14. Mejia-Barron, A., Valtierra-Rodriguez, M., Granados-Lieberman, D., et al.: Experimental data-based transient-stationary current model for inter-turn fault diagnostics in a transformer. *Electr. Power Syst. Res.* **152**, 306–315 (2017)
15. Majchrzak, V., Parent, G., Brudny, J.-F.: Influence of the electrical circuit configurations of a DVR coupling transformer with a magnetic bypass. *COMPEL Int. J. Comput. Math. Electr. Electron. Eng.* **36**(3), 804–810 (2017)