



Online Monitoring Method of Municipal Water Supply and Drainage Pipeline Based on Machine Vision

Yanmei Sun¹(✉) and Ya Xu²

¹ Yantai Vocational College, Yantai 264001, China
ymsun8058@163.com

² Modern College of Northwest University, Xi'an 710111, China

Abstract. Municipal water supply and drainage pipeline is a key component of underground pipeline, and the design of monitoring system is of great significance for its development. In this paper, the machine vision network is established, and the integrated monitoring system is introduced to design a monitoring method for municipal water supply and drainage pipelines. The communication sensor network is introduced to ensure the comprehensive monitoring of information. At the same time, the information management platform is introduced to combine digital monitoring and video monitoring, and alarm software is set to complete the accurate display of data. The method proposed in this paper can effectively combine big data content and urban management content, better extend the industrial value chain, and ensure the realization of urban intelligence. The experimental results show that the relative error of the online monitoring method of municipal water supply and drainage pipelines based on machine vision is always less than 0.02%, the monitoring process will not be affected by wind speed, and can well ensure the operation safety of municipal water supply and drainage pipelines.

Keywords: Machine Vision · Municipal Water Supply and Drainage · Water Supply and Drainage Pipeline · Pipeline Monitoring · Online Monitoring · Monitoring Methods

1 Introduction

The drainage pipeline is a continuous tunnel space with power, network, rainwater, heat supply and other pipelines. At the same time, there are also vents, manholes and feeding ports in the drainage pipeline. The drainage pipeline is equivalent to a “network system” under the municipal infrastructure. During the construction of a smart city, machine vision is introduced, combined with security management and command management, sensor nodes are set, The set sensor nodes are used to sense, monitor and perceive the data. The wireless sensor network can assist the drainage pipeline in comprehensive monitoring [1, 2].

At present, with the rapid increase of network equipment and data traffic, people have begun to use machine vision technology. Machine vision technology has the advantages

of high transmission rate and good overall performance, which can make the drainage pipeline safer. In addition, machine vision can combine artificial intelligence technology, big data and other technologies to establish drainage pipeline ventilation, drainage and other systems, and establish a comprehensive monitoring and management platform for drainage pipelines through big data technology. Through this platform, toxic gas, water pressure, air pressure and other environmental variables in the drainage pipeline can be collected, analyzed and monitored. Once the concentration of toxic gas exceeds the standard or other dangerous situations occur, Early warning and disposal can be carried out in a timely manner through online transmission, and efforts are made to build “municipal water supply and drainage pipeline”. On the basis of the above technologies, this paper designs an online monitoring method for municipal water supply and drainage pipelines based on machine vision. Machine vision technology is an interdisciplinary subject involving artificial intelligence, computer science, image processing, pattern recognition and many other fields. Machine vision mainly uses computers to simulate human visual functions, extract information from the images of objective objects, process and understand it, and finally use it for actual detection, measurement and control. Machine vision technology is characterized by high speed, large amount of information and multiple functions. The innovation of this method is to design the integrated monitoring system of municipal water supply and drainage pipeline under machine vision, which can ensure the stability of the bottom system and the top system of the drainage pipeline, so that both can operate stably and reliably.

2 Design of Comprehensive Monitoring System for Municipal Water Supply and Drainage Pipeline Based on Machine Vision

During the construction of drainage pipelines, it is necessary to minimize the potential safety hazards in all aspects of the drainage pipelines, and ensure that the top floor area and the bottom floor area are separated. The two areas are on two interfaces, so that the top floor area and the bottom floor area are managed separately. The bottom floor area has multiple functions, such as early warning, positioning, safety precautions, environmental monitoring, etc. The designed municipal water supply and drainage pipeline integrated system has multiple pipelines, heating pipelines, power pipelines Drainage pipeline, etc. The top level area needs to have the functions of gas management, power production management, water supply management and heat supply management. The bottom level area transmits the toxic gas concentration information, temperature information, humidity information and other environmental parameters of the drainage pipeline to the top level system through machine vision, so that the bottom level system can establish a connection with the top level system. Machine vision is the basic technology for the establishment of the municipal water supply and drainage pipeline comprehensive monitoring system. It can ensure the stability of the bottom system and the top system of the drainage pipeline, so that they can operate stably and reliably.

The monitoring system scheme designed in this paper is relatively simple. The construction unit should design a more complete, accurate and detailed construction schedule scheme according to the specific situation of the municipal water supply and drainage pipeline. The construction schedule scheme should specify the details of construction

preparation, personnel allocation, construction equipment selection, etc. In the actual construction process, the progress should be tracked regularly, and the data and content should be updated according to the actual situation. Ensure to complete the construction of municipal water supply and drainage pipelines within the time specified in the contract [3].

The machine vision is used to control the wireless sensor. The monitoring range of the wireless sensor to the drainage pipeline can reach up to 80 km, which is set at the outlet of the drainage pipeline [4]. This can reduce the limitations of uncontrollable factors to the wireless sensor. The wireless sensor has high computing power, but poor transmission performance. In order to solve this problem, a relay node is set in the drainage pipeline. To ensure the smooth transmission of environmental data.

3 Design of Municipal Water Supply and Drainage Pipeline Comprehensive Monitoring System Based on Machine Vision

The monitoring system structure is shown in Fig. 1:

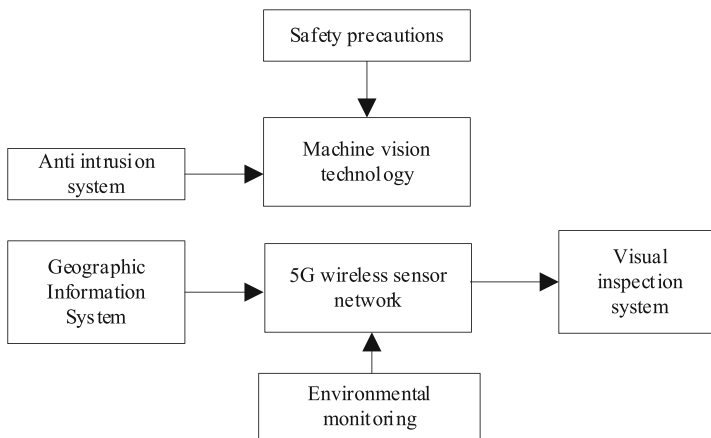

Fig. 1. Monitoring System Structure

According to Fig. 1, the structure of the integrated monitoring system for municipal water supply and drainage pipelines mainly includes intrusion prevention system, geographic information system, visual inspection system, etc. A new water environment monitoring and early warning solution based on machine vision technology is developed. It uses the 5G wireless sensor network to realize the integrated monitoring of municipal water supply and drainage pipelines by measuring the reflected light intensity of the water.

3.1 Design of Environmental Monitoring Subsystem

The environmental monitoring subsystem can monitor the surrounding environment. Vents, personnel entrances and exits, and escape exits are set in the fire protection area

of the drainage pipeline. In order to monitor the oxygen, methane, humidity, temperature and other environmental parameters in the drainage pipeline more effectively, the environmental subsystem is equipped with monitoring sensors to complete the connection with fans and pumps. The signal monitored by the monitoring sensor is transmitted to the control monitoring system through the pipeline, and transmitted to the monitoring terminal through the 5G wireless network [5]. On the display screen of the monitoring terminal, various environmental parameter data monitored by the monitoring sensor will be displayed. When the temperature, humidity, methane and other parameter concentration data exceed the standard, the monitoring center personnel will immediately send alarm information, report the location of potential safety hazards, and timely dispose of them.

3.2 Design of Equipment Monitoring Subsystem

Collect the parameters of lighting, fan, environmental parameter detector, drainage pump and other equipment in the drainage pipeline. After the collection is completed, the collected data will be transmitted through remote transmission, and logic control will be carried out. The reason for collecting the parameter data of these equipment is to provide data basis for the stable operation of electrical equipment, lighting equipment, ventilation equipment and other instruments. Through the monitoring command sent by the 5G base station, according to the collected equipment parameter data, the fan, lighting equipment, etc. are remotely monitored, and the start and stop of the drainage pump and electrical equipment are remotely controlled.

3.3 Design of Video Monitoring Subsystem

The network camera in the drainage pipeline integrated system is used to collect the image information of fans, lighting equipment, drainage pumps, etc. After being processed by the CPU of the monitoring system, the operating scene of various equipment in the current drainage pipeline can be displayed on the monitor. After the drainage pipeline is divided into 5G base stations and fire zones, network cameras are set at the entrance and exit to monitor the personnel in the drainage pipeline. The monitored video images are processed and displayed by the monitor, so as to monitor the entire drainage pipeline.

3.4 Intelligent Access Control System

The intelligent access control system includes electronic lock, LED display, card reader and identifier. The intelligent access control system needs to be set at the entrance and exit of the drainage pipeline, so as to control the identity of the personnel entering and leaving the drainage pipeline. When the drainage pipeline inspector shows the registered identification card outside the gate, the card reader will conduct identification and authentication, and the electronic control lock in the intelligent access control system will automatically open the gate. At this time, the LED display will record the time of entry and the identity information of the inductive card. When the drainage pipeline inspector leaves, directly touch the release key in the door, open the gate with the electronic control lock, and record the departure time with the LED display. In addition to

recording the entry and exit time, LED display can also display the operation data of fans, lighting devices, drainage pumps and other equipment in the drainage pipeline in real time, providing data basis for inspectors and maintenance personnel. The intelligent access control system can effectively prevent unauthorized personnel from entering the drainage pipeline.

3.5 Alarm System

The drainage pipeline contains a variety of combustibles, among which there are many cables, pipelines and optical cables. Once a violent fire occurs in the drainage pipeline, it will cause significant safety losses. The alarm system includes sensors, 5G monitoring base stations, communication base stations and temperature measuring optical fibers. Fire alarm screens are installed at the ground and underground monitoring terminals. The alarm information is received and displayed through optical cables, and the location of the fire is located [6]. In case of fire, the alarm in the drainage pipeline will give an alarm sound immediately, the monitoring terminal will call the video of the fire area and transmit it to the display, the fire emergency broadcast will immediately broadcast the alarm information, and the access control system will automatically open the door for release to ensure the rapid evacuation of trapped personnel. The automatic fire extinguishing device is turned on. After the fire is successfully extinguished, the fan will discharge the harmful gas in the drainage pipeline. The structure of the alarm system is shown in Fig. 2:

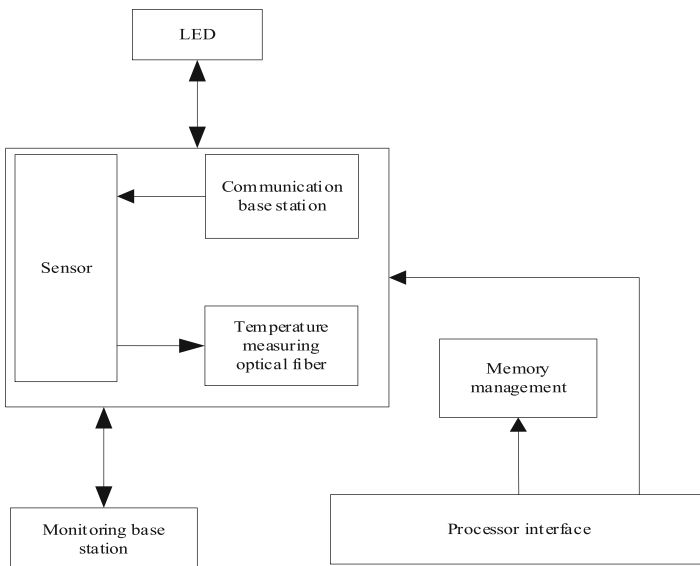

Fig. 2. Alarm System Structure

During the establishment of the alarm system, the construction department shall carefully review and confirm, set alarms according to the provisions of the construction cost, and strengthen the control of the number of alarms.

4 Integrated Information Management Platform of Municipal Water Supply and Drainage Pipeline Based on Machine Vision

Through the centralized management of the environmental monitoring subsystem, equipment monitoring subsystem, video monitoring subsystem, intelligent access control system and alarm system, the “smart” goal of drainage pipeline is achieved. The information management platform contains a large amount of pipeline corridor information. Cloud computing, big data, and data aggregation technologies are used to classify and summarize the sensor information, environmental monitoring information, equipment operation status information, fire alarm information, etc. in the municipal water supply and drainage pipeline comprehensive information management platform, and form information management images on the monitoring terminal display screen, sensor terminals, and mobile intelligent equipment of the drainage pipeline. So as to realize the command, dispatching, control and monitoring of drainage pipelines. The municipal water supply and drainage pipeline comprehensive information management platform mainly includes the following requirements:

First of all, the monitoring terminal can display all business information, provide data basis for the normal operation and production scheduling of the drainage pipeline, and solve the potential security risks in the drainage pipeline [7].

Machine vision is used to identify and verify each target in the pipe gallery. The 5G technology is used to determine the location of the drainage pipeline, read the electricity meter, conduct business survey, daily patrol inspection, etc., and return the fault location information and the fault image displayed by the monitoring terminal.

In order to effectively maintain the drainage pipeline, BIM and other technical means need to be used to call the large screen, monitoring display and other equipment in the pipe gallery and operate according to the business process [8].

Through the comprehensive information management platform for municipal water supply and drainage pipelines based on machine vision, the system can automatically log in to each subsystem, establish different accounts, manage permissions, and apply to other systems for targeted daily maintenance, which can simplify the approval process and improve work efficiency.

Construction process of water supply and drainage pipeline: grooving construction → non grooving construction → pipeline installation → auxiliary facilities → functional test → maintenance and repair.

- (1) Trench pipe construction: trench excavation (sloping/enclosure) - trench inspection - trench bottom reinforcement - cushion construction; It belongs to relevant knowledge points of foundation pit engineering.
- (2) Non grooved pipeline construction: pipe jacking, shield tunneling, shallow buried excavation, directional drilling, pipe tamping.

- (3) Pipeline installation: PE pipe hot melt or electric melt connection is used for water supply pipeline, and prefabricated concrete pipe is used for drainage pipeline, with socket connection.
- (4) Ancillary facilities: trenches/pipe channels, process wells, gate wells, inspection wells, pay attention to the construction requirements of masonry works.
- (5) Functional test: pressure pipeline water pressure test, non pressure pipeline tightness test, water supply pipeline flushing and disinfection.
- (6) Maintenance and repair: local repair (sealing method, patching method, articulated pipe method, local soft lining method, grouting method, robot method), full section repair (lining method, winding method, spraying method); Renewal of pipes (external extrusion and jacking of broken pipes).

5 On Line Monitoring Process of Municipal Water Supply and Drainage Pipeline Based on Machine Vision

5.1 Water Flow Status Tracking

Under the machine vision technology, the water flow in front is tracked in real time. Based on the continuous images, the search time is improved through the real-time tracking method. The target data in the image sequence is tracked in real time to determine the moving track of the target. The correlation tracking method, difference image and pattern recognition method are simultaneously applied to the machine vision technology. If the sampling interval of the image is short, it means that the moving distance of the detected target water state is small. Using a local window for detection can effectively improve the detection speed [9]. The process of water flow state road tracking in front of municipal water supply and drainage pipeline road based on machine vision is shown in Fig. 3:

The movement track of the detected target water flow state is a regular continuous movement track. After analyzing the state of the target that has occurred, predict the state that will occur, and then judge its possible position. The machine vision based water flow state target detection and tracking method for municipal water supply and drainage pipelines has the following advantages:

- (1) The prediction of single target trajectory is relatively accurate, the search scope of the search window is limited to a small range, the amount of calculation is greatly less, and the search speed is effectively improved;
- (2) If there are multiple similar retrieval targets in the same image, the target in the current image can be matched with the target in the previous image through target trajectory prediction to improve the tracking accuracy;
- (3) There may be noise or other objects similar to the target characteristics in the image. According to the trajectory prediction, the target can be well distinguished from other objects to determine the target you want to find.

Kalman filtering equation is added to remove the filtering of water flow status on the x and y axes, and the removal results are shown in Fig. 4.

It can be seen from Fig. 4 that at the initial stage, the error value is extremely large. With the increase of the measured value, the error of the x-axis curve and the error of the y-axis curve are decreasing. During the whole processing process, it is necessary

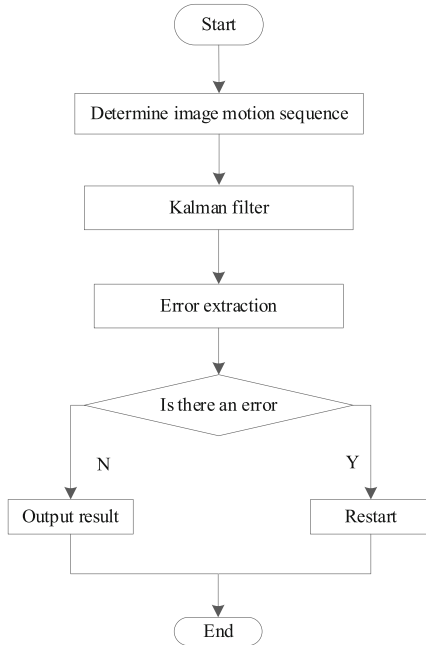

Fig. 3. Tracking process of municipal water supply and drainage pipeline flow state based on machine vision

to always make a simple judgment on the area near the prediction point to determine whether the water flow state exists. Compared with other methods, this method has great advantages [1].

5.2 Abnormal Monitoring Process

The anomaly monitoring process of municipal water supply and drainage pipelines is designed with machine vision technology, as shown in Fig. 5:

Step 1: locate the abnormal municipal water supply and drainage pipeline. First, initialize the microcontroller, analyze the abnormal line image data transmitted in the image acquisition pipeline using the image analysis function of machine vision technology [10], predict the suspected abnormal line points, preliminarily determine the suspected abnormal line points according to the values in the abnormal line image data, and upload the determination results to the intelligent judgment module in the machine vision system in the form of data packets, assuming that there are n suspected abnormal line points, The total number of lines is k , abnormal judgment is made for k lines in the environment with noise and interference, and the determined abnormal line points are set as m , comparative analysis is made for the suspected abnormal line points and the determined abnormal line points, overlapping abnormal line points and non overlapping abnormal line points are marked, and abnormal positioning is carried out respectively.

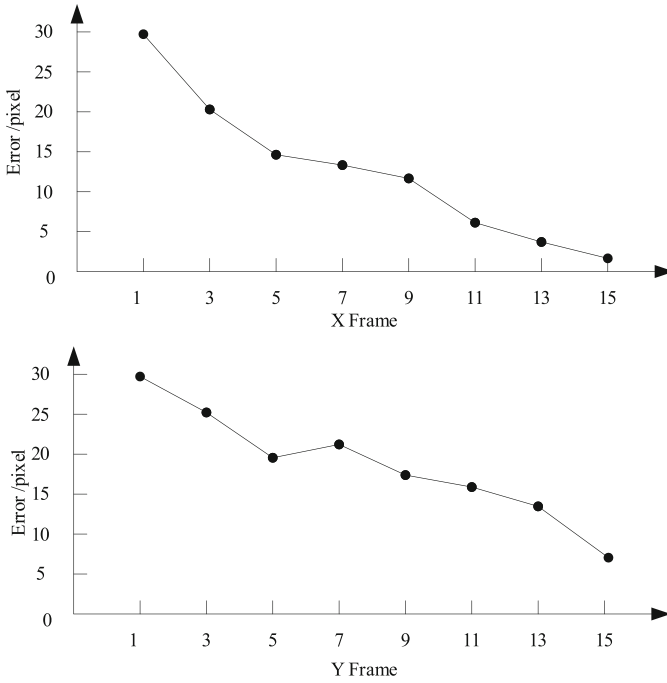

Fig. 4. Error Curve

The positioning formula established by machine vision is as follows:

$$W_n = \delta_m \sum_{x=1}^k y^{n+1} \tag{1}$$

In the formula, W_n represents abnormal line pixels acquired by machine vision; δ_m represents the morphological information of abnormal line points captured by machine vision; y^{n+1} represents the error weight of the $n + 1$ th suspected abnormal line point; x indicates abnormal points of pipeline. The abnormal lines in the pipeline can be located by the location formula of abnormal points in the pipeline.

Step 2: judge the line status. After positioning the abnormal lines, it is necessary to judge the line status before warning the abnormal lines to ensure the smooth implementation of automatic warning. In the water supply and drainage environment, machine vision technology is used to centralize line services. The line status includes two types. If the water supply and drainage pipe network system is in normal operation, the server displays normal; if the water supply and drainage pipe network system is in interrupted status, the server displays interrupted. Because the server will be affected by the network, lines, etc., it cannot display the status of the water supply and drainage pipe network system, Therefore, based on formula (1), the formula for displaying the status of water supply and drainage pipe network system is established in this paper:

$$Z_n = A^m B_{k+1} \tag{2}$$

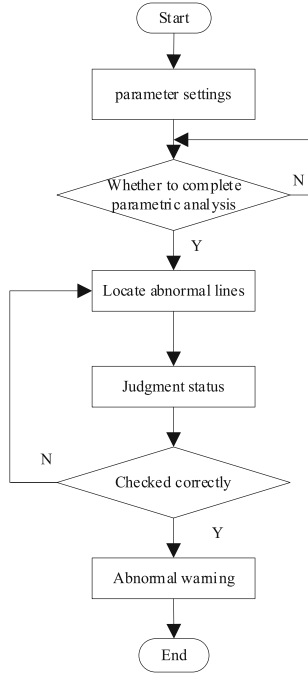

Fig. 5. Software Flow of Early Warning System

In the formula, Z_n represents the judgment result of water supply and drainage pipe network system status; A^m indicates that the water supply and drainage pipe network system is in operation when the abnormal line point is m ; B_{k+1} indicates that the water supply and drainage pipe network system is in an interrupted state under k lines. The current water supply and drainage pipe network system state can be judged by the state display formula.

Step 3: Give an early warning to the abnormal lines. Under the condition that the water supply and drainage pipe network system is in operation, an early warning is given for the abnormal lines. The early warning formula is as follows:

$$T = Z_n \sqrt{U} \quad (3)$$

In the formula, T represents the alert result; U indicates the collected warning voltage.

The abnormal energy consumption diffusion matrix $B_{N \times 1}$ of municipal water supply and drainage pipeline is expressed as:

$$B_{N \times 1} = S_{N \times L} + T_{L \times 1} \quad (4)$$

In the formula, $T_{L \times 1}$ is the time series matrix; $S_{N \times L}$ is the transient data attribute fusion matrix. According to the characteristics of the transient load of the drainage network, the same characteristic data of the abnormal state of the line is extracted, and the characteristic quantity $f_{ij}(n+1)$ of the transient line output power consumption of the drainage network is obtained.

Based on the determined distribution characteristics of drainage pipe network and random load $y_{R,j}(n)$, the overflow density function of abnormal data is established:

$$\mu_{MCMA} = f_{ij}(n+1)y_{R,j}(n)f(s_i) \quad (5)$$

According to AI self-learning theory and transient load data control method, load data balanced output is obtained as follows:

$$\sigma_y^2 = E\left[y_j^T(n)y_j^*(n)\right] \quad (6)$$

In the formula, E is the total load data. Under the maximum power gain of the system, the monitoring data acquisition model of the transient data of the drainage network is constructed, and the expression is:

$$e_{l,j} = \left(|y_{l,j}(n)|^2 - R_{2,l}\right) \times \sigma_y^2 \quad (7)$$

In the formula, $|y_{l,j}(n)|$ is the response characteristics of municipal water supply and drainage pipe network system affected by abnormal data; $R_{2,l}$ is the sample parameter of the system gain constraint under the maximum power meeting the conditions.

The early warning system will automatically send out an alarm sound, and the alarm signal will be sent to the image processing system of the machine vision system. Through this system, the specific location of the abnormal line point can be obtained, prompting the municipal water supply and drainage pipeline monitoring personnel to timely repair the abnormal line, so as to solve the line fault.

6 Experimental Study

In order to verify the effectiveness of the municipal water supply and drainage pipeline monitoring method based on machine vision proposed in this paper, the municipal water supply and drainage pipeline monitoring method based on machine vision proposed in this paper is selected for experimental comparison with the traditional municipal water supply and drainage pipeline monitoring method based on data topology and the municipal water supply and drainage pipeline monitoring method based on traveling wave technology. The experimental environment is implemented with the help of virtual machine VMW WORK station 8.2, which simulates five MASTER machines, and uses dual-core processors and SLAVER single-core processors. The programming software is the Eclipse SDK, and the network addresses are set to 192.168.121.5 and 192.168.122.5. Set the experimental parameters as shown in Table 1:

In order to ensure the experimental effect, before the experiment, set up wiring and install measuring devices in different places to facilitate better measurement. Install the measuring device. The length of the test line connecting line is 45m. Connect the sensor and other devices with a line to ensure that the line length is 15m. The connection diagram between the devices on the test site is shown in Fig. 6:

Table 1. Experimental Parameters

Project	Parameter
Video camera	Stereoscopic CCD camera
Radar	4GHz
Wave filter	Kalman filter
Image	Infrared thermal image
Memory	256G
Hard disk	20GB
CPU	370GHz

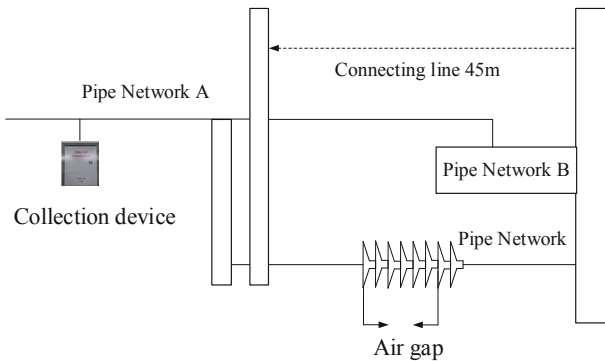
**Fig. 6.** Field Device Connection Diagram

During the experiment, the collected signal has the characteristics of high fluctuation amplitude and large wave head jitter, so the time spent from the initial state to the end state of the signal can be better determined during the acquisition. During the experiment in this paper, the line on site is too long, so it is impossible to apply voltage at both ends of the insulator, and the discharge of air gap cannot be guaranteed. In order to solve this problem, this paper introduces the line to reduce the impact of the line on the ground distribution process.

After the on-site device layout is completed, three systems are used to locate the municipal water supply and drainage pipeline monitoring methods based on machine vision, data topology, and traveling wave technology, and observe the positioning results on the warning host.

The positioning results of water supply and drainage pipe network A are shown in Fig. 7:

It can be seen from Fig. 7 that the fault location began to fluctuate at 0.45s. The online monitoring method proposed in this paper can predict the fault location at 0.45s. However, the response time of the traditional municipal water supply and drainage pipeline monitoring method based on data topology and the municipal water supply and drainage pipeline monitoring method based on traveling wave technology is too

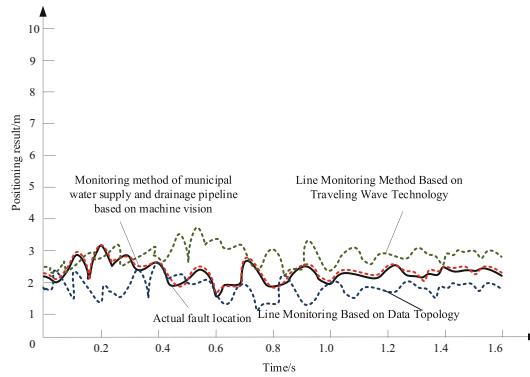

Fig. 7. Positioning Results of Water Supply and Drainage Pipe Network A

slow to predict the fault location change at 0.45s. The positioning error between the online monitoring method proposed in this paper and the actual fault location is less than 0.3m, while the positioning error between the municipal water supply and drainage pipeline monitoring method based on data topology and the actual fault location is more than 0.7m, while the positioning error of the municipal water supply and drainage pipeline monitoring method based on traveling wave technology is more than 1m, and the early-warning capability is the worst.

The positioning results of water supply and drainage pipe network B are shown in Fig. 8:

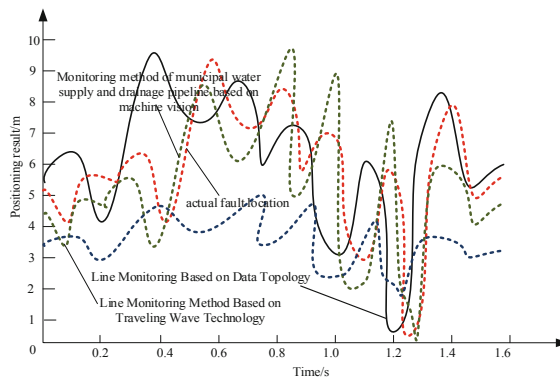

Fig. 8. Positioning Results of Water Supply and Drainage Pipe Network B

According to Fig. 8, the online monitoring method proposed in this paper always has a small difference from the actual fault location. In 1.1 s-1.6 s, the location of the fault is basically consistent with the actual fault location, and the location capability is extremely strong. However, the positioning error of the municipal water supply and drainage pipeline monitoring method based on traveling wave technology differs greatly from the actual position in 0.05 s, and the difference is about 0.5 m after 0.6 s. The

municipal water supply and drainage pipeline monitoring method based on data topology always differs from the actual location, which is difficult to meet the actual operation requirements.

To sum up, the positioning capability of the predetermined system proposed in this paper is better than that of the traditional early warning system. The positioning error for the line fault location is smaller, and the positioning capability with higher accuracy can meet the on-site requirements.

According to the above research data, carry out experimental research, adjust the municipal water supply and drainage pipeline data information, compare the environmental protection rate of the municipal water supply and drainage pipeline project applied in this technology with the environmental protection rate of the traditional municipal water supply and drainage pipeline project, and set the comparison results as shown in Table 2:

Table 2. Results of environmental protection rate of municipal water supply and drainage pipeline project under different methods

Study time/h	Environmental protection rate/%	
	Method in this paper	Traditional method
1	76%	52%
2	83%	64%
3	87%	71%
4	95%	77%
5	99%	84%

In Table 2, when the study time is 1h, the environmental protection rate of the project applied in this paper is 76%, and that of the traditional study is 52%. When the study time is 2h, the environmental protection rate of the project applied in this paper is 83%, and that of the traditional study is 64%. It can be seen that the application effect of this paper is better than that of traditional research. Because the application of this paper in the process of application constantly improves the degree of combination of technologies, and strengthens the construction management of municipal water supply and drainage pipelines to achieve reasonable application, thereby improving the application effect of the overall application, enhancing the degree of construction environmental protection, and achieving the purpose of application.

To sum up, the application effect of this paper is good, which can determine the application mode in municipal water supply and drainage pipelines, improve the effectiveness of the application, obtain better application data, and provide a solid data basis for subsequent research.

The comparison of feature value extraction results of the current frame is shown in Fig. 9 and Fig. 10.

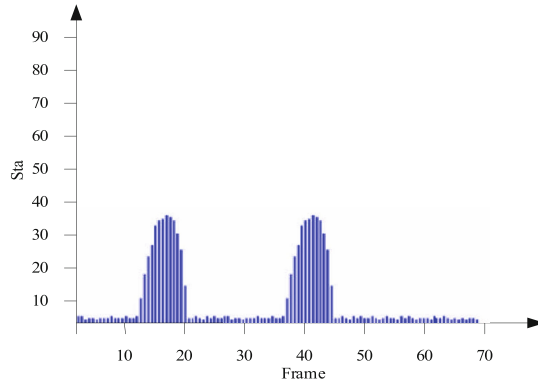

Fig. 9. Characteristic Value Extraction Results of Current Frame of Traditional Technology

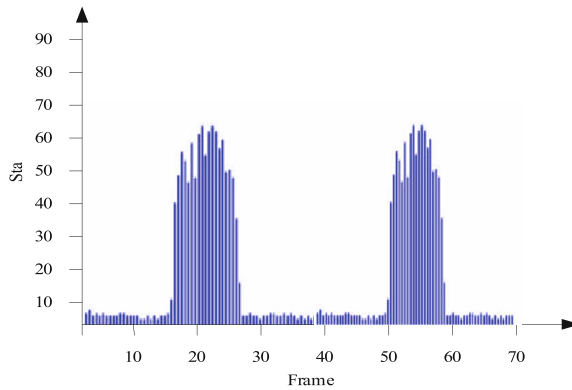

Fig. 10. Eigenvalue extraction results of current frame of this technology

By comparing Fig. 9 and Fig. 10, it can be seen that the current frame image obtained by this technology and the general outline of the water flow state are more obvious, and the difference between two adjacent frames can more clearly reflect the movement track of the water flow state. Although the traditional detection technology can detect the moving water flow state information, the expression results are not accurate enough, and the extracted feature values are not prominent enough.

The results of the water flow state positioning experiment are shown in Fig. 11.

According to the analysis of Fig. 11, with the increase of the number of water flow monitoring points, the positioning results and positioning results of this method and traditional methods are gradually increasing. When there are 10 water flow monitoring points, the positioning result of the traditional method is 95.07%, the positioning result of this method is 95.12%; When there are 30 water flow monitoring points, the positioning result of the traditional method is 95.24%, the positioning result of this method is 95.39%; When there are 50 water flow monitoring points, the positioning result of the traditional method is 97.74%, the positioning result of this method is 98.7%; When there are 70 water flow monitoring points, the positioning result of the traditional method is 98%, the

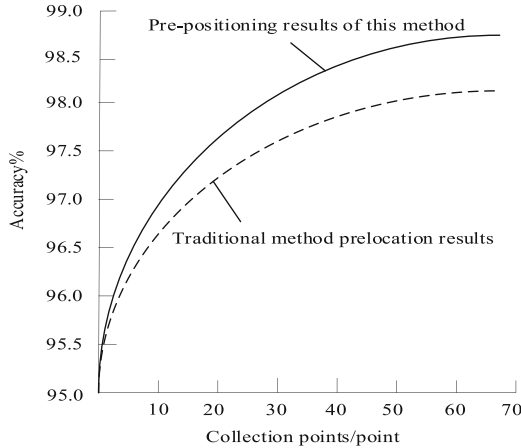

Fig. 11. Results of Water Flow Monitoring Point Positioning Experiment

positioning result of this method is 98.3%. According to the above experimental results, in the same time, the detection technology in this paper is more accurate in the front water flow state detected by the municipal water supply and drainage pipeline, and the extracted water flow state characteristics are more consistent with the actual information of the water flow state, which has a better effect in practical application.

7 Conclusion

The online monitoring method of municipal water supply and drainage pipelines plays a key role in the maintenance and operation of drainage pipelines. This paper designs five subsystems, including environmental monitoring subsystem, video monitoring subsystem, intelligent access control system, and builds a comprehensive information management platform for municipal water supply and drainage pipelines. Through this system, the safe and stable operation of municipal water supply and drainage pipelines can be achieved. The following conclusions are obtained through research:

- (1) The online monitoring method proposed in this paper can predict the fault location in 0.45 s, and the error of the actual fault location is less than 0.3 m, and the early warning ability is good;
- (2) The online monitoring method proposed in this paper always has a small difference from the actual fault location. In 1.1 s-1.6 s, the location of the fault is basically consistent with the actual fault location, and the location ability is very strong;
- (3) With the increase of research time, the environmental protection rate of the project applied in this paper is also increasing;
- (4) The current frame image obtained by this technology and the approximate outline of the flow state are more obvious. The difference between the two adjacent frames can more clearly reflect the movement trajectory of the flow state. The extracted flow state features are more consistent with the actual information of the flow state.

References

1. Yang, Y., Chen, Y., Tang, Z.: Analysis of the safety factors of municipal road undercrossing existing bridge based on fuzzy analytic hierarchy process methods. *Transp. Res. Rec.* **2675**(12), 915–928 (2021)
2. Talaat, M., Arafa, I., Metwally, H.: Advanced automation system for charging electric vehicles based on machine vision and finite element method. *IET Electr. Power Appl.* **14**(13), 2616–2623 (2020)
3. Zhang, Z., Bai, S., Xu, G.S., et al.: Research on the knitting needle detection system of a hosiery machine based on machine vision. *Text. Res. J.* **90**(15–16), 1730–1740 (2020)
4. Ramos, R., Douglas, D., Almeida, V.D., et al.: A video processing and machine vision-based automatic analyzer to determine sequentially total suspended and settleable solids in wastewater. *Anal. Chim. Acta* **1206**, 1–10 (2022)
5. Zza, B., Yang, L.B., Qi, H.B., et al.: Multi-information online detection of coal quality based on machine vision. *Powder Technol.* **374**, 250–262 (2020)
6. Valkova, T., Parravicini, V., Saracevic, E., et al.: A method to estimate the direct nitrous oxide emissions of municipal wastewater treatment plants based on the degree of nitrogen removal. *J. Environ. Manage.* **279**, 111563 (2020)
7. Qin, A., Guo, L., You, Z., et al.: Research on automatic monitoring method of face milling cutter wear based on dynamic image sequence. *The Int. J. Advanced Manufacturing Technol.* **110**(11–12), 1–12 (2020)
8. Berkmortel, N., Curtis, M., Johnson, C., et al.: Development of a mechatronic system for plant recognition and intra-row weeding with machine vision. *J. Agric. Sci.* **13**(3), 1–8 (2021)
9. Wei, W., Yin, J., Zhang, J., et al.: Wear and breakage detection of integral spiral end milling cutters based on machine vision. *Materials* **14**(19), 5690 (2021)
10. Baoshui, Z., Hailong, H., Hao, T.: Method for tamper detecting of copied images of small targets based on machine vision. *Computer Simulation* **38**(8), 227–304 (2021)