



# High-Frequency Non-intrusive Load Monitoring System Based on KNN and QDA Ensemble Learning Algorithm

Wang Zihao and Zhou Zou<sup>(✉)</sup>

School of Information and Communication, Guilin University of Electronic Technology,  
Guilin 541004, China  
zhouzou@guet.edu.cn

**Abstract.** In recent years Non-Intrusive Load Monitoring (NILM) technology has developed rapidly, with applications covering power management, smart homes, fault detection, equipment condition monitoring and other areas. In commercial building power inspection scenarios, traditional inspection methods often suffer from low efficiency, high costs, missed inspections and false inspections. At present, the use of NILM technology can identify the working status of each power equipment, significantly reducing the probability of missed and false detection. However, there is still the problem of not being able to balance classification efficiency and classification accuracy. In this study, a high frequency fast non-intrusive load monitoring system is designed. The use of high-frequency data sets significantly reduces the data acquisition time. To further reduce the time cost, an ensemble learning algorithm based on K-Nearest Neighbor (KNN) and Quadratic Discriminant Analysis (QDA) is proposed. The algorithm not only achieves an F1-score of 90%, but also has an average training time of 0.207 s. In comparison with six baseline algorithms such as stacked ensemble learning (SEL) and radial basis function neural networks (RBFNN), the proposed algorithm not only maintains a high F1-score, but also significantly reduces the average training time. In practical scenarios, the model can be deployed faster and maintain high recognition accuracy.

**Keywords:** Ensemble Learning · NILM · High-Frequency Dataset · Electrical Inspection

## 1 Introduction

In commercial building electrical inspections, there are often problems such as low inspection efficiency, high costs, missed inspections and false inspections. NILM technology can continuously monitor the status of electrical equipment and quickly locate problem appliances, significantly improving inspection efficiency and reducing inspection costs. The development of artificial intelligence provides more possibilities for the application of NILM technology. For example, the data collected by NILM technology

can be analyzed and processed by artificial intelligence algorithms to better identify individual electrical appliances and their working status, and to analyze electrical behavior. However, there is still the problem of not being able to balance classification efficiency with classification accuracy.

With the development of deep learning, [1, 2] introduced deep ensemble learning and deep reinforcement learning into power system protection. This method achieves some results, but its low sampling efficiency and large sample requirements reduce its usefulness.

For this reason, the researcher focused on using NILM techniques to implement commercial building power patrol. [3] proposed a new NILM method for identifying distributed energy resources appliance features collected from the low-voltage side of distribution transformers and analyzed its classification performance using three machine learning algorithms: KNN, random forest (RF) and multilayer perceptron (MP). The test results show good results on low frequency datasets, but do not show results on high frequency datasets. A novel DiffNILM model was proposed in [4], but the test results only showed good results on a few key metrics on low-frequency datasets, and the model was too large and took too long to train. The study actually found that using low-frequency datasets reduced the cost but did not address the problem of balancing recognition efficiency and recognition accuracy.

As a result, researchers have begun to experiment with high frequency datasets and have characterized them in the frequency domain. A comparison of NILM methods featuring harmonics was conducted by [5]. Using high frequency datasets, machine algorithms such as decision trees (DT), KNN, neural network, ensemble learning and support vector machines, were tested for load classification, with ensemble learning based on boosted trees achieving high accuracy but sacrificing excessive efficiency with long training times. In practice it was shown that using the frequency domain as a feature would improve accuracy but significantly increase the training time.

The study was conducted in the time domain as a feature. [6] proposed a stacked ensemble learning (SEL) model based on light gradient boosting machine (LGBM), KNN, RF, SVM, and logistic regression (LR), which achieved a high F1-score on high-frequency datasets, but with a long average training time. [7] built a hardware and software system for load classification using the NILM technique. In tests on high-frequency datasets, the random forest algorithm achieved a high F1-score, but with a long training time. It still did not have a good balance between recognition efficiency and recognition accuracy.

[8] attempted to use deep learning for data analysis and proposed a radial basis function neural networks (RBFNN) designed based on a multi-objective genetic algorithm, which achieves lower network complexity and cost but has lower accuracy. Starting from traditional mathematical methods, [9] proposed an event-driven factorial hidden Markov model, which reduced the computational complexity to a certain extent, but had a large prediction bias on high-frequency datasets. [10] proposed a new method based on Gaussian latent Dirichlet allocation to extract the global component of the generalized energy signal, but the model is prone to overfitting.

Analysis of the literature reveals that the NILM method is currently used mainstream in commercial building power inspections. And it mostly adopts time domain features

of high frequency datasets, which can improve the classification accuracy to a certain extent, but still has some limitations in the classification efficiency.

## 2 Research Framework

The current NILM technology still has the problem of not being able to combine classification efficiency with classification accuracy. For this reason, this paper proposes a high frequency fast non-intrusive load monitoring system. The use of high-frequency data sets significantly reduces the data acquisition time. Based on this, an ensemble learning algorithm based on KNN and QDA is proposed to further reduce the time cost. The data is fed into two classifiers and the results of the two classifiers are adjudicated at the adjudicator for output. The algorithm significantly improves the training efficiency while maintaining a high classification accuracy. A new optimised solution is proposed for the difficult problem in commercial building electrical inspections. The system research framework is illustrated in Fig. 1 below.

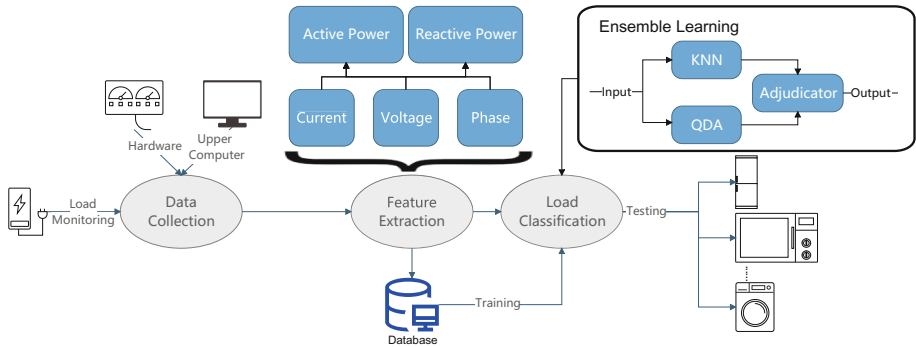
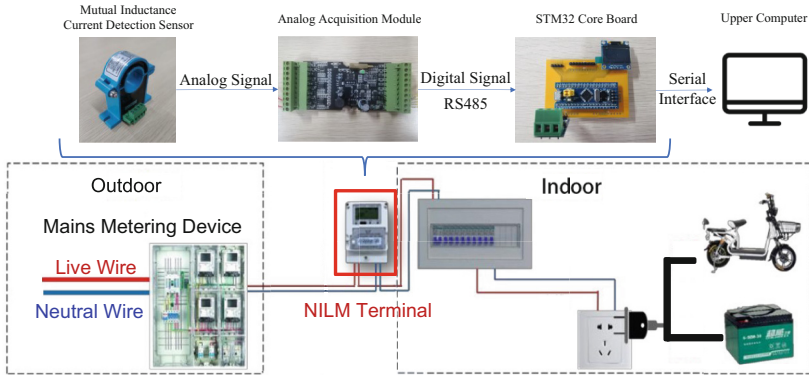

**Fig. 1.** NILM system research framework

The NILM process can be divided into three stages. In the first data acquisition stage, the system hardware enables 10 kHz high frequency load feature sampling, and the sampled data is transferred to the upper computer via the serial interface after a series of processing. In the second feature extraction stage, active and reactive power are used as two-dimensional data features. This better reflects the working state and energy consumption of the appliances, simplifies the input dimension of the machine learning algorithm and improves the efficiency and accuracy of load identification. In the third load classification stage, an ensemble learning algorithm based on KNN and QDA is used to achieve fast training and high accuracy prediction of the load classification model.

## 3 Data Collection

In this study, the data acquisition phase of the NILM algorithm was carried out via the hardware section in Fig. 2 and the upper computer.



**Fig. 2.** High frequency non-invasive load identification system

From Fig. 2, the hardware part consists of mutual inductance current detection sensor module, analogue acquisition module, STM32 core board and the upper computer.

The mutual current detection sensor module, using an Asmik open-close Hall AC current sensor, model MIK-HRI-100A, with a sampling frequency of 10 kHz, is responsible for detecting AC current data and converting it into a 4-20 mA analogue current signal output. The physical diagram is shown in Fig. 3 below.

The analogue acquisition module, which is responsible for receiving the analogue signals transmitted by the mutual current detection sensor module and converting the 0-100 V and 4-20 mA analogue signals into digital signals. It communicates with centralised control equipment such as industrial control machines and PLCs via RS485. It supports the Modbus protocol and can be networked with other Modbus devices for data sharing and remote monitoring. The physical diagram is shown in Fig. 4 below.

The STM32 core board, using the F103C8T6 chip, receives voltage and current data transmitted from the analogue acquisition module via the RS485 line and communicates with the upper computer via the serial interface, displaying the collected data on the upper computer to facilitate data analysis and processing by the user. The physical diagram is shown in Fig. 5 below. the upper computer uses QT to write the data processing software. The data transmitted from the STM32 core board is received via the serial port, displayed and automatically saved as a CSV file.



**Fig. 3.** Mutual inductance current detection sensor



**Fig. 4.** Analog acquisition module



**Fig. 5.** STM32 core board

The data acquisition system described above enables sampling of high frequency load characteristics at 10 kHz. The data collected is individually sampled for individual appliance operation, and after collecting multiple appliances separately, the high frequency sampling data set is constructed.

## 4 Feature Extraction

This study uses active and reactive power as data features to construct a high frequency data set. After the data collection above, voltage rms  $U$ , voltage phase  $\theta_U$ , current rms  $I$ , current phase  $\theta_I$  data can be obtained. Data pre-processing is carried out to remove duplicate values and fill in missing values with nearby data averages. Based on basic physics, define the voltage and current phase differences  $\Delta\theta$ , and

$$\Delta\theta = \theta_U - \theta_I. \quad (1)$$

Active power  $P$  is the average of the integrals of the instantaneous power emitted or consumed by the load during one cycle in an AC circuit. For sinusoidal alternating current, the integration operation yields that

$$P = UI \cos(\Delta\theta). \quad (2)$$

Reactive power  $Q$  means that in an AC circuit with reactance, the electric or magnetic field absorbs energy from the power supply for part of a cycle and releases it for another part of the cycle, with the average power being zero throughout the cycle, but energy is constantly exchanged between the power supply and the reactance element. The maximum value of the exchange rate is the reactive power, the

$$Q = UI \sin(\Delta\theta). \quad (3)$$

With the above formula, the collected data can be transformed into active and reactive power. In this paper, data is collected for several common household appliances, namely washing machines, rice cookers and water purifiers. The collected data is sampled for individual appliances working individually. The data are collected separately for several appliances, and all the collected data are constructed into a high frequency data set characterised by active and reactive power, with a sampling frequency of 10 kHz, and with active power as the horizontal coordinate and reactive power as the vertical coordinate, the high frequency data set is drawn in Fig. 6

Figure 6 above shows the basic distribution of load feature data for washing machines, rice cookers, water purifiers and other appliances in the high frequency data set. Active and reactive power are used as data features in this study because they can better reflect the operating state and energy consumption of the appliances, while features such as current, voltage and harmonics may be affected by noise or interference. Its can also simplify the input dimension of the machine learning algorithm, facilitate mathematical operations and statistical analysis, and improve the efficiency and accuracy of load identification.<sup>[11]</sup>

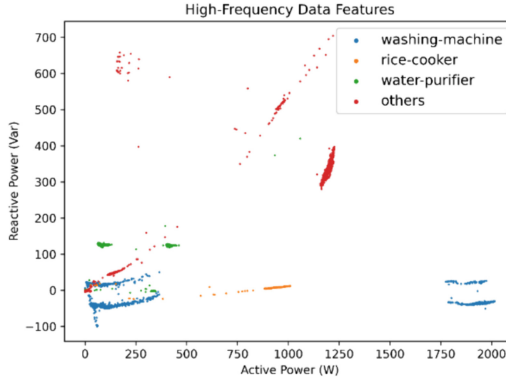

Fig. 6. High frequency data features

### 5 Load Classification Algorithm

In this study, an efficient ensemble learning algorithm based on KNN and QDA is proposed using a high-frequency dataset. The data sampling time and model training time are significantly reduced with a high accuracy of load classification.

The KNN algorithm is an instance-based learning method, and its main idea is: with the data and labels in the training set known, input test data, compare the features of the test data with each other with the corresponding features in the training set, and find the top K data in the training set that are most similar to it, then the category corresponding to that test data is the one with the most occurrences among the K data. Such an idea ensures that the KNN algorithm has the advantage of fast training.

The QDA algorithm has some similarities with the linear discriminant analysis (LDA) algorithm, a discriminant analysis method in classification algorithms. LDA is used to reduce high-dimensional data to one or two dimensions by projecting the samples and then classifying them.

If the vector  $\vec{x}$  and the vector  $\vec{\omega}$  are known, the inner product can be expressed as

$$\vec{x} \cdot \vec{\omega} = |\vec{x}| |\vec{\omega}| \cos \theta. \tag{4}$$

When the modulus of  $\vec{\omega}$  is of length 1, the inner product of the two vectors becomes the projection of  $\vec{x}$  onto  $\vec{\omega}$ , i.e.

$$\vec{x} \cdot \vec{\omega} = |\vec{x}| |\vec{\omega}| \cos \theta = |\vec{x}| \cos \theta \tag{5}$$

Since it is necessary to consider how to make the projection points of the different classes of samples as far apart as possible, the distance between the projections of the mean vectors  $\mu_i, i \in \{0, 1\}$ . of the two classes on a straight line is used to measure the interclass distance, i.e.

$$(\omega^T \mu_o - \omega^T \mu_1)^2 = \omega^T (\mu_o - \mu_1) (\mu_o - \mu_1)^T \omega. \tag{6}$$

Simplify the formula so that

$$S_b = (\mu_0 - \mu_1) (\mu_0 - \mu_1)^T \tag{7}$$

then Eq. (6) is rewritten as

$$\omega^T \mu_o - \omega^T \mu_1 = \omega^T S_b \omega. \quad (8)$$

Similarly, a metric is proposed to measure the proximity of projection points of similar samples. Since the larger the variance the more dispersed the data, the idea of variance is used to measure the degree of dispersion between the same set of data. Based on this, the variance of category  $X_o$  and category  $X_1$  can be calculated separately. The variance in the following equation is not the true standard variance and is not divided by the sample size.

$$\begin{aligned} \text{var}(X_o) &= \sum_{x \in X_o} (\omega^T x - \omega^T \mu_o)^2 \\ \text{var}(X_1) &= \sum_{x \in X_1} (\omega^T x - \omega^T \mu_1)^2. \end{aligned} \quad (9)$$

The sum of the variances of the two categories is.

$$\text{var}(X_o) + \text{var}(X_1) = \omega^T \left( \sum_{x \in X_o} (x - \mu_o)(x - \mu_o)^T + \sum_{x \in X_1} (x - \mu_1)(x - \mu_1)^T \right) \omega. \quad (10)$$

Simplify the equation so that

$$S\omega = \sum_{x \in X_o} (x - \mu_o)(x - \mu_o)^T + \sum_{x \in X_1} (x - \mu_1)(x - \mu_1)^T. \quad (11)$$

then the variance between the two categories can be rewritten as

$$\text{var}(X_o) + \text{var}(X_1) = \omega^T S_o \omega. \quad (12)$$

According to the objective of LDA, it is necessary to make the samples as close as possible to each other, i.e., to make  $\omega^T S_w \omega$  as small as possible. The different samples are as far away from each other as possible, i.e., let  $\omega^T S_b \omega$  be as large as possible. The objective function J can be obtained by combining

$$J = \frac{\omega^T S_b \omega}{\omega^T S_o \omega}. \quad (13)$$

The larger the value of, the more consistent it is with the objectives of the LDA.

QDA is a supervised learning algorithm. While LDA assumes the same covariance matrix for different categories, QDA builds on LDA by assuming different covariance matrices for different categories. LDA can only learn linear bounds, whereas QDA can learn quadratic bounds, allowing for non-linear separation of data and therefore greater flexibility. In addition, QDA has no hyperparameters, has closed-form solutions and is easy to compute. Therefore, QDA has better classification results.

The ensemble learning algorithm based on KNN and QDA is built on the principle of hard voting, i.e., the final result is decided based on the majority of the minority. The pseudo code is as follows.

---

Algorithm 1 Ensemble learning algorithm based on KNN and QDA

---

Input: All data in the test set ( $P, Q, realclass$ )

Output: F1-score

```

1: Begin
2: For 1 to n; //Input all test set samples one by one.
3:   Enter a set of data( $P_n, Q_n, realclass_n$ );
4:    $class_{n0} \leftarrow 0$ ;  $class_{n1} \leftarrow 0$ ;
5:   KNN classification  $\rightarrow P_{n0}^{KNN}, P_{n1}^{KNN}$ ; //Probability of Class 0 and Class 1.
6:   If  $P_{n0}^{KNN} > P_{n1}^{KNN}$   $class_{n0} + = 1$ ;
7:   Else  $class_{n1} + = 1$ ;
8:   QDA classification  $\rightarrow P_{n0}^{QDA}, P_{n1}^{QDA}$ ; // Probability of Class 0 and Class 1.
9:   End if
10:  If  $P_{n0}^{QDA} > P_{n1}^{QDA}$   $class_{n0} + = 1$ ;
11:  Else  $class_{n1} + = 1$ ;

---

12:  End if
13:  If  $class_{n0} > class_{n1}$   $class_n \leftarrow 0$ ; // Classified as Class 0.
14:  Else if  $class_{n1} < class_{n2}$   $class_n \leftarrow 1$ ; // Classified as Class 1.
15:    Else if  $P_{n1} > P_{n2}$   $class_n \leftarrow 0$ ; // Classified as Class 0.
16:    Else if  $P_{n1} \leq P_{n2}$   $class_n \leftarrow 1$ ; // Classified as Class 1.
17:  End if
18:  If  $class_n = realclass_n$  //Compared with the real classification.
19:   $T + = 1$ ; //This sample is classified correctly;
20:  Else
21:   $F + = 1$ ; //This sample is misclassified;
22:  End if
23: End for
24: Calculate TP, FN, FP, TN, Accuracy, Precision, Recall and F1-score;
25: End

```

---

Hard voting is simpler and faster compared to soft voting, and can reduce overfitting. Such aggregated voting classifiers tend to achieve higher accuracy than individual classifiers. both KNN and QDA are among the weak learners, and by integrating multiple weak learners together, the final voting classifier obtained can be a strong learner. The ensemble learning classifier constructed has both low time complexity, non-linear classification effects, significantly reduced model training time and guaranteed load classification accuracy.<sup>[12, 13]</sup>

## 6 Simulation Experiments and Data Analysis

The data of four appliances in the high frequency dataset were labelled with corresponding labels, namely washing machine, rice cooker, water purifier and other appliances, in preparation for supervised learning. Eighty percent of the data is considered as the training dataset and 20 percent as the test dataset.

The KNN has a number of neighbours of 5, with equidistant weights and distance  $\rho$  using Euclidean distance, i.e.

$$\rho = \sqrt{(x_2 - x_1)^2 + (y_1 - y_2)^2}. \quad (14)$$

DT measure is the Gini coefficient with a maximum depth of 5 and a maximum number of leaf nodes of 100. RF with a maximum depth of 50 and a number of trees of 100, limiting the number of features considered when branching to 1. MP has three hidden layers, each with 32 neurons, a RELU function for the activation function, a constant learning rate and an optimiser using Adam.

The above algorithm is evaluated for accuracy and a binary confusion matrix is introduced. The confusion matrix consists of true positives (TP), true negatives (TN), false positives (FP) and false negatives (FN). The accuracy performance metric is assessed by the following equation,

$$Accuracy = \frac{TP + TN}{TP + FP + TN + FN}. \quad (15)$$

$$Precision = \frac{TP}{TP + FP}. \quad (16)$$

$$Recall = \frac{TP}{TP + FN}. \quad (17)$$

$$F1 - score = \frac{2 \times Precision \times Recall}{Precision + Recall}. \quad (18)$$

In this study, the F1-score metric was used to measure the accuracy of the algorithms. To assess the efficiency of each algorithm, the training time for each appliance of each model is counted and the average training time for each algorithm is calculated.

In this paper, a high frequency dataset of appliance loads is constructed with time domain active and reactive power as features. An efficient ensemble learning algorithm based on KNN and QDA is proposed for the classification of appliance load feature data and compared with machine learning algorithms KNN, DT, RF, MP, SEL and RFBNN. The prediction results are shown in Table 1 below.

Each appliance in each algorithm imports 200,000 samples for training, with training time and average training time in seconds. Observing Table 1 above, it can be seen that the proposed ensemble learning algorithm based on KNN and QDA achieves an average accuracy of 90% and an average training time of 0.207 s. Considering the average training time, the proposed ensemble learning algorithm is slightly slower than the KNN and RF algorithms, but the difference is not more than one order of magnitude, while the accuracy rate gains significant improvement. Although the training speed of

**Table 1.** Comparison of machine learning algorithms

Algorithm	Load	F1-Score	Training Time	Average F1-Score	Average Training Time
KNN	Washing-Machine	0.8573	0.174	0.82	0.176
	Rice-Cooker	0.7646	0.176		
	Water-Purifier	0.8514	0.178		
Decision Tree	Washing-Machine	0.8624	0.086	0.83	0.078
	Rice-Cooker	0.7648	0.092		
	Water-Purifier	0.8514	0.056		
Random Forest	Washing-Machine	0.8574	5.094	0.82	4.487
	Rice-Cooker	0.7645	4.660		
	Water-Purifier	0.8467	3.708		
Multilayer Perceptron	Washing-Machine	0.8571	11.318	0.80	14.12
	Rice-Cooker	0.7649	21.490		
	Water-Purifier	0.7787	9.554		
SEL	Washing-Machine	0.8006	453.092	0.62	434.66
	Rice-Cooker	0.4069	213.578		
	Water-Purifier	0.6447	637.309		
RBFNN	Washing-Machine	0.8070	49.935	0.65	52.38
	Rice-Cooker	0.7800	60.090		
	Water-Purifier	0.3550	47.106		
<b>Propose</b>	Washing-Machine	0.9743	0.208	<b>0.90</b>	<b>0.207</b>
	Rice-Cooker	0.8625	0.204		
	Water-Purifier	0.8515	0.210		

the DT is faster, it is affected by the dimensionality of the input data, and if the input data dimensionality increases further, the speed of the DT algorithm will be significantly reduced. The proposed ensemble learning algorithm is significantly faster than the RF, MP, SEL and RBFNN algorithms, and retains its accuracy advantage. Thus, the proposed ensemble learning algorithm based on KNN and QDA not only maintains a higher accuracy rate but also significantly reduces the average training time compared to the other six baseline algorithms. It remedies the problem that the NILM technique cannot balance classification efficiency and classification accuracy.

## 7 Conclusion

In commercial building power inspection scenarios, traditional power inspection often suffers from low inspection efficiency, high costs, missed inspections and false inspections. At present, NILM technology can identify the working status of each electrical

equipment and significantly reduce the probability of missed and false inspections. However, there is still the problem of not being able to balance classification efficiency and classification accuracy. In this study, a high frequency fast non-intrusive load monitoring system is designed. The hardware enables high frequency feature acquisition and significantly reduces the data acquisition time. To further reduce the time cost, an ensemble learning algorithm based on KNN and QDA is proposed. Not only does the proposed algorithm achieve an F1-Score of 90%, the average training time for 200,000 samples is only 0.207 s. When compared with six baseline algorithms, it not only maintains a high classification accuracy but also significantly reduces the average training time. It compensates for the inability of the NILM technique to balance classification efficiency and classification accuracy.

Using the designed high frequency fast non-intrusive load monitoring system, the identification of individual electrical appliances and their operating status is achieved by analyzing the load data of each appliance. By continuously monitoring the status of electrical equipment and quickly locating problematic appliances, a better understanding of the electricity consumption of the whole building can be achieved, reducing the probability of missed and erroneous inspections and improving inspection efficiency [14].

## References

1. Su, H., Lai, C.: Dynamic-deep-ensemble-learning scheme for probabilistic voltage stability margin estimation to enhance resilient power grid monitoring. In: *IEEE Transact Ind. Elect* 1–10 (2023).
2. El-Toukhy, A.T., Badr, M.M., Mahmoud, M.M.E.A., et al.: Electricity theft detection using deep reinforcement learning in smart power grids. *IEEE Access* **11**, 59558–59574 (2023)
3. Jaramillo, A.F.M., Lopez-Lorente, J., Laverty, D.M., et al.: Distributed energy resources electric profile identification in low voltage networks using supervised machine learning techniques. *IEEE Access* **11**, 19469–19486 (2023)
4. Sun, R.C., Dong, K., Zhao, J.F.: DiffNILM: A novel framework for non-intrusive load monitoring based on the conditional diffusion model. *Sensors* **23**(7), 2912–2920 (2023)
5. Al-Khadher, O., Mukhtaruddin A., Hashim, FR., et al.: Comparison of non-intrusive load monitoring supervised methods using harmonics as feature. In: *Proceedings of the International Conference on Electrical, Computer and Energy Technologies*, pp. 1–6 (2022).
6. Li, Y.Z., Wang, H.X., Yang, Z.H., et al.: Stacking ensemble learning-based load identification considering feature fusion by cyber-physical approach. *IEEE Sens. J.* **23**(6), 5997–6007 (2023)
7. Gurbuz, FB., Bayindir, R., and Vadi, S.: Comprehensive non-intrusive load monitoring process: device event detection, device feature extraction and device identification using KNN, random forest and decision tree. In: *Proceedings of the 10th International Conference on Renewable Energy Research and Application (ICRERA)*, pp. 447–452 (2021).
8. Laouali, I., Gomes, I., Ruano, M.D.G., et al.: Energy disaggregation using multi-objective genetic algorithm designed neural networks. *Energies* **15**(23), 2912–2920 (2022)
9. Yan, L., Tian, W., Han, J.Y., et al.: Event-driven two-stage solution to non-intrusive load monitoring. *Appl. Energy* (2022). <https://doi.org/10.1016/j.apenergy.2022.118627>
10. Mohamad, S., Bouchachia, A.: Online Gaussian LDA for unsupervised pattern mining from utility usage data. In: *Proceedings of the 19th IEEE International Conference on Machine Learning and Applications (ICMLA)*, pp. 41–48 (2020).

11. Wang, L., Mao, S., Wilamowski, B.M., et al.: Pre-trained models for non-intrusive appliance load monitoring. *IEEE Trans. Green Commun. Netw.* **6**(1), 56–68 (2022)
12. Nie, Z.J., Yang, Y.B., Xu, Q.S.: An ensemble-policy non-intrusive load monitoring technique based entirely on deep feature-guided attention mechanism. *Energy. Build.* (2022). <https://doi.org/10.1016/j.enbuild.2022.112356>
13. Chang, X.M., Li, W., Xia, C.Q., et al.: Transferable tree-based ensemble model for non-intrusive load monitoring. *IEEE. Transact. Sustain. Comput.* **7**(4), 970–981 (2023)
14. Hu, M.Z., Tao, S.Y., Fan, H.T., et al.: Non-intrusive load monitoring for residential appliances with ultra-sparse sample and real-time computation. *Sensors* **21**, 16 (2021)