



# Design of Telemedicine and Health Care System Based on Embedded Technology

Shufeng Zhuo<sup>1</sup>, Yi Hu<sup>2</sup>, Xinyao Liu<sup>3</sup>, and Zixiu Zou<sup>4,5</sup> (✉)

<sup>1</sup> The Internet of Things and Artificial Intelligence College, Fujian Polytechnic of Information Technology, Fuzhou 350003, China

<sup>2</sup> Henan Information Engineering School, Zhengzhou 450000, China

<sup>3</sup> Imperial Vision Technology Company Limited, Fuzhou 350001, China

<sup>4</sup> Fuzhou Institute of Technology, Fuzhou 350506, China

55607@qq.com

<sup>5</sup> SEGI University, 47810 Petaling Jaya, Selangor, Malaysia

**Abstract.** In order to improve the monitoring accuracy of physiological parameters and the effect of telemedicine, a new telemedicine and health care system based on embedded technology was designed. Use the embedded server to realize the information interaction between the client and the Web server. Send data to the server through the monitoring network terminal, and use the data acquisition module to obtain two parts of the data of the blood pressure module and the blood oxygen module. Monitor physiological signals with embedded monitors. Use embedded technology to search for telemedicine information, and combine encryption algorithms to encrypt the information. Calculate the distance between the monitoring signal to be authenticated sent by the embedded server and the storage database to ensure the safe transmission of the signal and avoid external interference, thus completing the design of the remote medical care system. It can be seen from the experimental results that the blood pressure fluctuation range monitored by the system is 100mmHg-160mmHg, the maximum error between the blood oxygen measurement value and the actual data is only 1%, and the pulse rate data is consistent with the actual data, indicating that the monitoring results using this system are accurate, the practical application effect is good.

**Keywords:** Embedded Technology · Telemedicine · Health Care System · Monitoring Network End · Server · Encryption Algorithm

## 1 Introduction

With the improvement of people's living standards, people pay more and more attention to the health of themselves and their families. Coupled with the popularity of PC and the improvement of Internet speed and bandwidth, people are more longing for and need a practical home telemedicine and health care system to facilitate access to doctor diagnosis services. In China, the development of telemedicine is still in its infancy. It

mainly targets a small number of patients with difficult diseases. Due to the high medical price and less civil use, the popularity of telemedicine system is low and the market promotion is difficult, which limits the rapid development of telemedicine technology and its industry to a certain extent. Telemedicine mainly provides people with medical information and services through the use of telecommunication, computer, multimedia and other technologies, that is, the basic physiological data information of human body needed for medical treatment is transmitted in different places [1]. The transmission of this medical and physiological information can be realized by using various existing communication technologies such as telephone line, ISDN, frame relay, ATM and satellite. Current telemedicine systems mainly use two types of technologies, one is to store data and then transmit it to transmit physiological data from one end to the other, which are non-real-time applications, such as electrocardiograms, CT scans and Transmission of images such as X-rays. Another more and more widely used is the two-way interactive, face-to-face visualization technology, that is, real-time mutual communication, consultation and consultation through PCs, cameras, and audio equipment terminals.

According to the logical relationship between the constructed telemedicine and healthcare system and various architecture levels of different platforms, combined with the Internet of Things technology to analyze the “sensing and knowing” characteristics of the telemedicine and healthcare system, so as to realize the real-time monitoring of the telemedicine and healthcare system; The proposed method based on SpringMvc the telemedicine health care system of the architecture model uses the SpringMvc architecture model to build software programs, combines user needs with qualitative problems in the medical system, and establishes a complete telemedicine health care system. Traditional medical technology is easily limited by time and space, often has very large limitations, and cannot provide guaranteed medical services for a wide range of people. Generally speaking, to realize a stable and reliable telemedicine system, we must solve two important problems: one is to have a stable, reliable and flexible front-end data acquisition equipment; The second is how to realize the interaction between server and client. In view of the above problems, the design of telemedicine and health care system based on embedded technology is proposed. Through the integration of user-side detection instruments, the signals of different detection instruments are coordinated and processed, and the detection data is transmitted through the computer serial interface. At the same time, it is displayed in the user terminal and saved in the network system database. Through programming, the examination data stored in the database of patients can be compared and classified, so as to form a permanent electronic medical record, which can more clearly analyze the pathological conditions of patients and determine the treatment plan. The system also provides emergency treatment, information center and real-time communication system to meet the needs of patients’ health care information and real-time dialogue with doctors.

Based on the above analysis, this paper designs a telemedicine system based on embedded technology. The main structure of this paper is as follows:

- (1) Analyze the embedded application of telemedicine system, and determine the overall structure of the medical care system.
- (2) The hardware structure of the healthcare system is designed, mainly including embedded server, monitoring network, data acquisition, and embedded monitor.

It mainly uses embedded server to realize information interaction between client and Web server. The monitoring network terminal sends data to the server, and the data acquisition module is used to obtain the data of blood pressure module and blood oxygen module.

- (3) Embedded technology is used to search telemedicine information, and encryption algorithm is used to encrypt the information. The distance between the monitoring signal to be authenticated sent by the embedded server and the storage database is calculated to ensure the safe transmission of the signal and avoid external interference, thus completing the design of the telemedicine system.
- (4) The fluctuation range of blood pressure monitored by the system in this paper is to verify the error between the blood oxygen measurement value and the actual data, and the gap between the pulse rate data and the actual data, so as to verify the accuracy of the system monitoring results designed in this paper.
- (5) Summarize the full text and draw a conclusion.

## 2 Embedded Applications of Telehealth Care Systems

Telemedicine is a medical model that uses modern telecommunication and multimedia technology to realize a variety of medical functions such as disease diagnosis, treatment and health care in different places. Telemedicine system is usually composed of three-level structure, namely client, application server and database server [2]. As a kind of telemedicine system, home health care system will collect the physiological parameters and video, audio, video and other data of the monitored person, and then transmit them to the server monitoring center in real time through the network for dynamic tracking of pathological development, so as to ensure timely diagnosis and treatment.

In recent years, with the rapid development of computer network communication technology and the continuous increase of wired network bandwidth, the content of telemedicine has been further enriched, and its connotation and practical significance have been increased. In the application of remote consultation, from the original transmission of pictures and words in advance before consultation, it can now transmit patient information in real time and realize “face-to-face” HD video dialogue [3]. In order to strengthen the modern information management of hospitals and improve work efficiency, a family medical care system based on embedded technology and a three-tier architecture of “family service network doctor” with family as the core is studied and implemented. The terminal is connected to the Internet through Ethernet, and uses TCP/IP protocol for data transmission to realize the collection, transmission and telemedicine of physiological parameter signals. The server side provides corresponding health data and services for different end users [4]. The working process collects various physiological parameters of the elderly through digital instruments such as blood pressure meter, heart rate meter, blood glucose meter, etc., and sends it to the embedded medical care terminal system through the RS232 serial port or USB port, and then the terminal system packages the data and transmits it through the network. It is transmitted to the server side, and the server side will get in touch with the hospital and the attending physician in time after processing the data [5]. The client and the server can be connected to a camera and a microphone, and both sides can conduct video telemedicine.

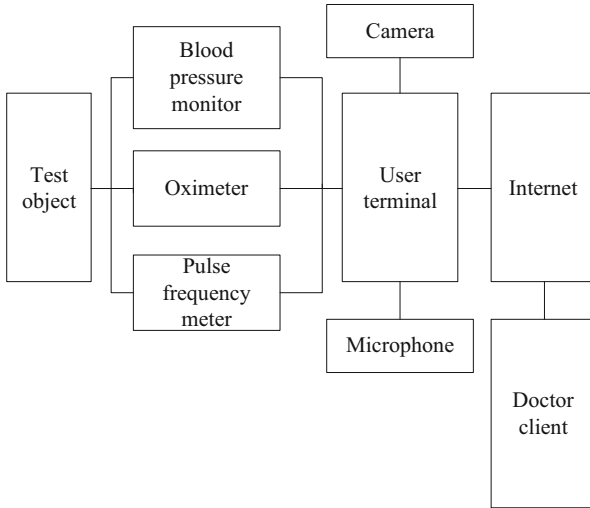

**Fig. 1.** Overall structure of the healthcare system

Figure 1 is a general structural diagram of the health care system.

The significance of embedded health care system is to break through regional boundaries, so that the elderly can enjoy high-level medical services at home, so as to allocate medical resources more reasonably. The system introduces high-definition image monitoring technology. While providing remote medical health detection data services (realizing the function of doctors' remote "cutting"), it adds technical support for front-end patient audio and video monitoring, which makes the basis of doctors' diagnosis more sufficient, the interaction between doctors and patients more direct and convenient, closer to the medical environment of local diagnosis, and realizes the function of doctors' remote "looking, smelling and asking". Secondly, in the past, telemedicine systems generally used PC as the front-end acquisition device, and used C/S service architecture to realize the doctor client. The data processed by the client software needs the help of the intermediate transfer server [6]. This not only makes the front-end system less mobile, but also the back-end doctor terminal relies too much on the service mode and performance of the intermediate server, resulting in poor system compatibility. The system adopts an embedded Web server as the transmission core of telemedicine data, and the front-end hardware adopts a multimedia SoC solution. Thirdly, the disadvantage of the software terminal is that if the doctor wants to browse the real-time medical information of the patient, he must install the software separately. For different telemedicine front-end acquisition systems, the data protocol is not standardized, so that the compatibility of the software cannot be guaranteed, which will bring a lot of inconvenience to the end user. With the support of embedded web server, this system uses web browsers as client terminals to improve the compatibility and adaptability of clients, so that doctors can diagnose patients in real time on PCs, mobile phones and even TVs.

### 3 System Hardware Structure Design

The system design adopts the client/server/application software/database structure, and the Internet connects the client and server. The client is mainly composed of audio and video system, physiological sensor, signal conditioning circuit, data acquisition card, virtual instrument application software and self diagnosis information database. The signal conditioning circuit is to amplify and filter the physiological electrical signal obtained by the sensor to achieve the appropriate electrical signal.

#### 3.1 Embedded Server Side

The server is mainly composed of the website of online hospital, online doctor and user/doctor information database. Among them, online doctors need to be equipped with application software and audio and video system. The main function of the server website is to provide Internet access services, user authentication management, open interactive health care and medical environment, and the generation of dynamic web pages; Firstly, the information database is mainly used for the code authentication management of users and network doctors, the generation of dynamic web pages, and other services provided in the website; Another main function is to store, open and process the data files of doctors' acceptance and diagnosis; The application software used by online doctors is the same as that used by customers [7, 8]. Users and network doctors in health care and medical centers have their own fixed codes and passwords. After logging in to the website server, the user can actively choose a doctor to consult and see a doctor by checking the resume of the doctor on duty [9].

The embedded server module is an ARM embedded structure running in the SoC. It is based on the Linux real-time operating system and a web server. The web browser function is implemented at the front end. The client can realize the connection with the web server as long as the browser downloads and browses the web page [10]. In addition, the embedded web server is also responsible for the IP protocol transmission of medical health and physiological data, audio, and video monitoring data. At the same time, the server can also respond to the setting instructions of the web client terminal and transfer them into corresponding serial port or FPGA instructions. Set data acquisition module, audio and video encoding hardware equipment.

#### 3.2 Monitoring Network Terminal

Telemedicine monitoring network can monitor patients remotely through different communication media, which is generally composed of front-end monitor, communication media and monitoring center station. Front end monitors are usually placed in family or community clinics. The monitoring center station can be located in community clinics or large hospitals, while telephone lines, power lines, ISDN (Integrated Services Digital Network), satellites, Internet and some private networks can be used as the communication media of the network. A telemedicine monitoring system composed of multiple medical monitors based on the embedded microprocessor module RCM3000 and the monitoring center station through the Internet [11].

In the network design, a client/server structure is adopted. The embedded monitor used by each family is the client, and the monitoring center station with three slave servers is the server. The embedded monitor can measure and display Sao<sub>2</sub> (blood oxygen saturation), HR (heart rate), ECG (electrocardiographic waveform), T (body temperature) and NIBP (non-invasive blood pressure) and other physiological parameters, and when the client and the server require connection after the application is allowed, it can continuously send data to the server through the Internet. At the same time, the emergency call signal of the patient being monitored can also be sent to the server. According to the different identifiers of the data received by the server, the data is processed by the Sao<sub>2</sub> slave server, the NIBP slave server and the ECG slave server, and the server can also send relevant commands to the client. The server will receive the monitoring data of multiple clients at the same time and save the data records. Doctors can select certain patients on the screen for real-time observation or view historical records for analysis and diagnosis.

### 3.3 Data Acquisition Terminal

The data acquisition module includes a blood pressure module and a blood oxygen module. Both modules have corresponding measurement circuits, and the measurement circuit includes a power supply circuit, a signal processing circuit, an analog-to-digital conversion circuit, an ARM control circuit, and a protection circuit. Each data acquisition module only needs to connect the corresponding external electrodes and sensors to complete the acquisition of physiological parameters under the control command of the ARMS processor.

#### **Blood Pressure Collection Module**

Blood pressure is a very important physiological parameter of the human body. The prevalence of hypertension is high in our population, especially in the elderly. Generally, what we are familiar with is the high and low pressure value, which refers to the systolic and diastolic blood pressure in medicine. The systole and diastole of the heart in a cycle will form two beats in blood pressure, so we can test these two values. The normal range of blood pressure values is: high pressure 90-130mmHg, low pressure 60-90mmHg. Blood pressure measurement adopts non-invasive vibration measurement method, which can measure systolic blood pressure, diastolic blood pressure and mean blood pressure. The noninvasive vibration measurement method is similar to the Coriolis sound method. During the measurement, the arterial blood flow is blocked through the cuff, and the pressure sensor is used to detect the shock wave of the gas in the cuff during the gradual deflation of the cuff. The slow deflation of the cuff causes the gradual change of the cuff volume, and then changes the air pressure inside the cuff. Through the pressure sensor, the signal quantity with the air pressure value of an approximate slope can be obtained. The real-time cuff pressure can be obtained after filtering, amplification, analog-to-digital conversion and other processing.

#### **Blood Oxygen Collection Module**

Blood oxygen refers to blood oxygen saturation, which is the ratio of hemoglobin that has

been combined with oxygen in the blood to the total hemoglobin, and the unit is percentage. The premise of blood oxygen measurement is that hemoglobin and oxyhemoglobin in human blood have different absorption coefficients for light of different wavelengths. Blood oxygen represents the oxygen content in human blood, and is defined as the concentration of oxyhemoglobin in tissues to total hemoglobin (including hemoglobin and oxyhemoglobin). At present, there are few measurement methods of blood oxygen saturation, which mainly distinguish the different component concentrations and blood oxygen saturation in the blood pressure in the finger by the conduction strength of the blood in the finger to the light. Therefore, the measurement method is the fingertip photoelectric sensor measurement method. The sensor is made into a fingertip and put on the finger. 660nm red light and 940nm near-infrared light are injected into the finger blood container. The transmitted light has different intensity due to different refractive index, so as to measure the amount of hemoglobin in blood and blood oxygen saturation, which provides a non-invasive blood oxygen measurement method for clinic. During blood oxygen measurement, two different photodiodes on the blood oxygen probe emit two kinds of light with different wavelengths at the same time, and the light passes through human fingers and is detected by the photoelectric detector. When the artery beats, the light intensity measured by the photoelectric detector is small, while during the interval between two pulses of the artery, the light intensity measured by the photoelectric detector is large. The difference between the two light intensity measurements is the value of the light intensity absorbed by the pulsatile arterial blood. It can be seen that the signal of blood oxygen measurement also contains pulse information, and the pulse parameters of human body can be obtained by blood oxygen measurement.

### 3.4 Embedded Monitor

The embedded monitor is composed of the Ethernet microprocessor module of Z-WORLD Company in the United States and three physiological parameter detection modules, keyboard and its trigger circuit, liquid crystal display and module switch, etc., as shown in Fig. 2.

The RCM3000 module includes the microprocessor Rabbit3000, 512K Flash for storing programs, 512K SRAM for storing data, 54 parallel input and output ports and 6 serial ports. In addition, it has a Base-T LAN or internet interface, and provides the source code of TCP/IP protocol stack without edition fee.

The ECG module can detect parameters such as full-lead ECG signal, respiration wave, heart rate, respiration rate and body temperature; It has four-level ECG signal gain, four-level respiratory wave program-controlled gain, and three-level filtering; PC2 and PC3) are connected to it. The NIBP module can measure the blood pressure of adults or children; it has manual or automatic measurement function; it is connected to it through the serial port D (PC0 and PC1) of the RCM3000. Sao2 module can measure blood oxygen saturation, plethysmogram, intensity, pulse rate and other parameters; can change patient mode and sensitivity level, can perform low perfusion measurement, and can resist motion interference; through serial port B (PC4 and PC5) of RCM3000 connected to it. The three switches connected to PD0-PD2 determine whether the above three modules work.

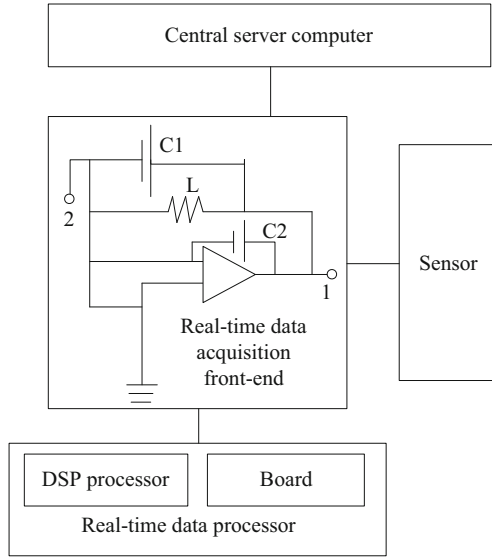

Fig. 2. Schematic diagram of the structure of the embedded monitor

## 4 Software Part Design

The hardware platform constitutes the overall framework and trunk of the telemedicine system. On the basis of the hardware platform, we also need to develop the application software through the software platform, so that the hardware platform can run. Hardware platform and software platform work together to form a complete telemedicine system. The monitoring terminal is an important part of the telemedicine system, which realizes the physiological data acquisition function of terminal patients. At the same time, it can realize the data communication with the upper computer monitoring terminal through the data transmission module, and transmit the measured physiological parameters to the doctors or experts in the monitoring center for diagnosis. The main function of embedded operating system is to be responsible for the allocation of software and hardware resources, task scheduling and the control and coordination of various concurrent activities of the whole system. The main components are composed of underlying driver software, system kernel, driver interface, communication protocol and image interface. The application software is at the top of the embedded system, and it is oriented to users to complete specific functions and requirements.

### 4.1 Telemedicine Information Search Based on Embedded Technology

The telemedicine information search engine based on embedded technology mainly connects various systems in a point-to-point way. The purpose of embedded technology search is to prevent developers from using HTTP, HTML and JavaScript, but it can be used if necessary. Users can customize web applications through HTML, style sheets, and templates. Using the embedded technology search structure to achieve a variety of

data integration, the key is to integrate the middleware application interface, and use point-to-point interaction and information-based middleware interaction to ensure the consistency of data sources, and thus perform data encryption search.

The symmetric encryption algorithm is used to encrypt the data, and the data attribute is AND type access structure tree. The structure tree is transformed into the main disjunctive access structure tree through the disjunctive normal form solution method. The symmetric key is encrypted through the access structure tree. Assuming that the sub access structure belongs to different attribute institutions, the ciphertext corresponding to the sub search structure can be expressed as:

$$k_x = (D_x, c_0, \{c'_i\}_{i=1,2,\dots,i}) \quad (1)$$

In formula (1),  $x$  represents the data collected by the sensor;  $D_x$  represents the access structure;  $c_0$  represents the ciphertext component;  $c'_i$  represents the main disjunctive access structure tree ciphertext component. With the support of this ciphertext, the data encryption access process is designed as follows: For each attribute except the last attribute in the sub-search structure tree, a random number is selected for each attribute, and the value corresponding to the attribute is obtained. The formula is:

$$\zeta_n = m - \sum_{n=1}^i \zeta_i \quad (2)$$

In formula (2),  $m$  represents the total number;  $\zeta_i$  stands for random number. Upload the ciphertext corresponding to all sub search structure trees to the cloud storage server. To judge whether the initial uploaded data meets the optimal upload value, based on the distance between each cluster center, the formula is:

$$d(l_1, l_2) = \sqrt{\sum_{m=1}^n (l_{1,m} - l_{2,m})^2} \quad (3)$$

In formula (3),  $l_1$  and  $l_2$  are the inter-class distances of the actual clustering centers;  $n$  is the clustering item. A threshold  $\beta$  is set. When  $d \leq \beta$ , the initial upload data meets the optimal upload value, otherwise, it does not. The clustering effect is adjusted in real time to improve the rationality of classification and provide data support for data encryption processing, thus completing data encryption search.

## 4.2 Physiological Signal Monitoring

The Web application established by the embedded technology search component is registered on the server. Through the registration of the embedded technology search component, the whole medical service for patients, including flow, flow direction and processing process, can be completed. Using this engine, physiological signals can be searched.

### Blood Pressure Monitoring

Blood pressure monitoring is to monitor the blood flow of a certain cross-section in the

blood vessel, that is, to monitor the volume velocity, that is, the ratio of the pressure at both ends of the blood vessel to the friction resistance between the blood flow and the blood vessel wall [12]. Friction resistance depends on blood viscosity and vessel radius, which can be described as:

$$\alpha = \frac{\rho \cdot d}{\pi r^2} \quad (4)$$

In formula (4),  $r$  is the radius of the blood vessel;  $\rho$  is the viscosity of the blood;  $d$  is the length of the blood vessel. The monitoring of blood pressure is the monitoring of human vascular function. In clinical practice, the blood pressure of patients can be known by monitoring frictional resistance.

### Pulse Oximetry Monitoring

Oxyhemoglobin is formed by the combination of hemoglobin and oxygen, and these proteins flow through the blood throughout the body and release oxygen throughout the body to maintain normal cellular metabolism. Pulse oximetry monitoring is based on the principle of different light absorption rates of proteins in blood vessels to monitor, which is determined by the ratio of transmitted light to incident light. Based on this, the absorbance of a substance can be expressed as:

$$\delta = \ln \frac{1}{\lambda \rho' H} \quad (5)$$

In formula (5),  $\lambda$  represents the absorption coefficient;  $\rho'$  refers to the concentration of light absorbing substance;  $H$  is the thickness of the substance. In the infrared region, there is little difference between the absorbance coefficients of hemoglobin and oxygen; In the red light area, the absorption coefficient of hemoglobin is larger, and the absorption coefficient of oxygen is basically not [13].

### 4.3 Monitoring Signal Transmission Based on Multi-threading

In the process of physiological monitoring signal transmission, initiating the conversion and reading the converted result is an asynchronous process. After the program starts the conversion of the physiological monitoring signal, it has been querying the status of the converted flag bit. Once the conversion is completed, it will read the result, otherwise it will be in a waiting state. This processing method is obviously problematic, because when an error occurs in the conversion process of the physiological monitoring signal and the process cannot be carried out smoothly, the system will be deadlocked by waiting. This situation in the physiological monitoring signal test system will cause the system to respond slowly and reduce its efficiency. In order to solve the above problems, a multi-threading mechanism can be introduced into the program. Physiological monitoring signals are centrally monitored through multi-threading to create interrupts and handle two sub-threads, as shown in Fig. 3.

Once a thread is created, it will run independently of the thread that created it. All threads in a process share the virtual address space of the process, so that all global

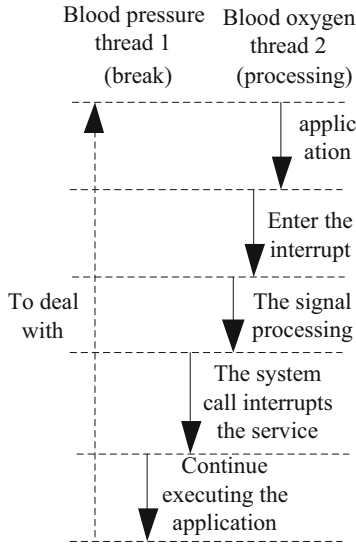

Fig. 3. Physiological monitoring signal centralized monitoring thread

variables of the process can be monitored [14]. The process requires signal encryption, and the formula can be expressed as:

$$c' = E(\psi(a) + \psi(b) - \psi(e)) \tag{6}$$

In formula (6),  $\psi(a)$ ,  $\psi(b)$ ,  $\psi(e)$  represents the processing result, encryption result and random information respectively. Calculate the distance between the monitoring signal to be authenticated sent by the embedded server and the storage database, the formula is:

$$H(u, o) = \sum u[B] \oplus o[B] \tag{7}$$

In formula (7), both  $u[B]$  and  $o[B]$  indicate that the fuzzy monitoring signal to be authenticated corresponds to the symbol of the stored database;  $B$  means code;  $\oplus$  stands for exclusive or operation. The smaller the Hamming distance is, the stronger the anti-interference ability of the code group is. When the embedded server uses the private key to decrypt, the Hamming distance is compared with the preset threshold. If the Hamming distance is greater than the set threshold, it indicates that the security of the monitoring signal cannot be effectively protected; If the Hamming distance is less than the set threshold, then the safety of the monitoring signal is effectively protected. Based on the strong security of multi-threaded processing technology, all signals can be safely transmitted, avoiding external interference, and providing technical guarantee for multi-party encryption of monitoring signal transmission [15]. Using this mechanism, the main thread can monitor the sub threads through the global flag, which can effectively overcome the stagnation and untimely response in the transmission of physiological monitoring signals, and greatly improve the efficiency of the system.

## 5 Experiments

### 5.1 Construction of Virtual Experimental Environment

Constrained by the limited resources of the embedded platform, the first step in the development of embedded software is to establish a cross-compilation environment on the PC host, that is, the code written on the host is generated after cross-compilation and can be applied to the target platform. Binary executable program. The operating system of the PC host is RedHat Linux9.0, and the specific implementation method is to use the virtual machine VMware Workstation software platform to completely install the RedHat Linux9.0 operating system. The ARMS development board of TQ2440 is selected to transplant the Linux2.6 system as the operating system of the embedded software platform. As an open source operating system, Linux is completely free, safe and reliable, supports multi-user multi-tasking and runs independently at the same time, and has sufficient follow-up support. In addition, the Linux system supports a wide range of file systems and drivers, has a good graphical interface, and supports QT testing. To successfully transplant the Linux operating system on the TQ2440 development board, you need to burn the Linux kernel and file system separately. The kernel ensures the realization of functions such as management, communication, and network support for each application on the development board. The file system is the basis of all data in the entire system, and all file information of the system is contained in the file system. In this topic, the supporting resources of the TQ2440 development board include the successfully compiled kernel and file system images, which can be programmed directly on the development board. The process of programming uses the download mode of u-boot, and connects the development board with the HyperTerminal on the PC to realize the mutual data transfer. The specific steps are as follows:

Step 1: Connect the development board to the PC, and turn on the super terminal of the PC, and set the port to 100000 bits/second. 8 data bits, 1 stop bit, no parity and data flow control.

Step 2: Long press the space bar on the keyboard, and power on the development board to enter the USB Download mode.

Step 3: Enter in the super terminal, find the kernel image file zImage.bin in the specified path of the development board resource package and transfer it, and select the default factory-programmed kernel image file. After the transfer is completed, uboot will perform the programming of the kernel file by itself.

Step 4: After the kernel is burnt, enter and choose to burn the Linux file system in the HyperTerminal, and find the corresponding file system root.bin in the specified path for transmission. In this design, the default factory-programmed file system is selected. After the file is transferred, uboot will automatically complete the burning of the file system. It can be seen from the programming information that during the programming process of the file system, there are bad blocks in the NAND Flash, and during the programming process, uboot automatically skips them, and the bad blocks will not cause the normal use of the development board. Unnecessary influence. After completing the programming of the Linux kernel and file system in turn, the QTopia platform with a friendly user interface can be established on the development board to complete the

real-time display of physiological parameters such as blood pressure, blood pressure, ECG, body temperature, and respiration.

## 5.2 Experimental Setup

The medical information search engine based on IntraWeb is used to obtain medical information, and data encryption access is carried out through symmetric encryption algorithm. Therefore, the experimental device selected is the medical information integration device, as shown in Fig. 4.

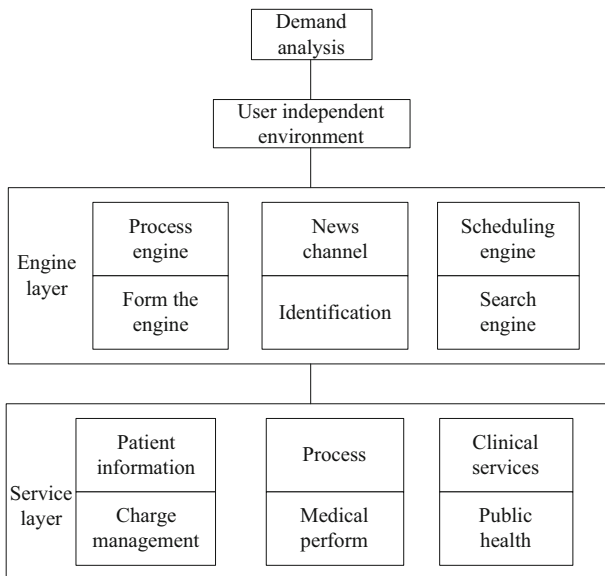

**Fig. 4.** Regional medical information integration model

According to the selected regional medical information integration device, this process needs the support of information sharing. The simulation analysis method is used to verify the process model, and the rationality analysis and optimization of the medical business process are carried out before the implementation of the project.

## 5.3 Analysis of Experimental Data

During system debugging, the IP address of the monitoring terminal is uniformly set to 192.168.10.20. After the connection between the monitoring terminal and the upper computer monitoring software is completed, the three physiological parameters of blood pressure, blood oxygen and pulse rate are collected to debug the collection and transmission functions of each module software. The LCD screen of the monitoring terminal and the upper computer software have the function of displaying physiological parameters. The complete overview of the display interface is shown in Fig. 5 respectively.

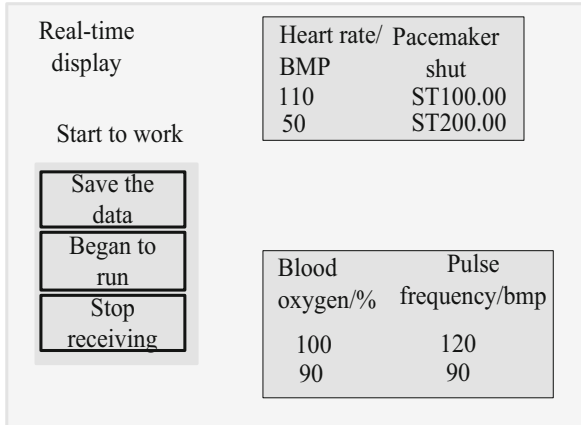

Fig. 5. Monitoring terminal data display interface

The right side of the interface diagram is the value display area of physiological parameters, which can display the real-time display values of physiological parameters; The left side is the waveform display area of physiological parameters, which can display the real-time waveform of measured physiological parameters.

**Blood Pressure Data**

In the debugging of the blood pressure module, in order to test the accuracy of the blood pressure measurement software, seven different time points were selected at 16:00 and 22:00 on the same day, and the same measurement object was measured seven times. The measurement results are as follows: The fluctuation range of human diastolic blood pressure measured 7 times is 100 mmHg–160 mmHg. During measurement, set the upper and lower limits of diastolic blood pressure to 170 mmHg and 90 mmHg respectively. When the value of diastolic blood pressure is higher than 170 mmHg or lower than 90 mmHg, it means that the measured value is abnormal, and the measurement module will issue an abnormal alarm.

**Blood Oxygen Data**

The blood oxygen value of human body is calculated according to the different absorption rate of red light under the pulsation of human artery. Therefore, the information collected by the blood oxygen module used in this design also includes the pulse information of human body, that is, the pulse frequency of artery (pulse rate, unit: bpm). In order to accurately reflect the soft measurement performance of blood oxygen measurement, seven different measurement objects are selected to measure blood oxygen at the same time, numbered 1, 2, 3, 4, 5, 6 and 7 respectively, and all seven measurement objects are in a calm state. The measurement results showed that the measured blood oxygen values of the seven subjects were 88%, 91%, 92%, 90%, 89%, 90% and 95% respectively, and the pulse rate values were 60 bpm, 80 bpm, 90 bpm, 70 bpm, 62 bpm, 64 bpm and 70 bpm respectively. Set the normal range of blood oxygen to 90%-100%, and the normal range of pulse rate to 50bpm-120bpm. When the measured value exceeds this range, the system will send an alarm message.

## 5.4 Experimental Results and Analysis

In order to verify the rationality of the design of the telemedicine health care system based on embedded technology, it is compared with the monitoring data of the system based on the Internet of Things technology and the system based on the SpringMvc architecture pattern.

### Blood Pressure Data Analysis

The blood pressure data monitoring results of the three systems are shown in Fig. 6.

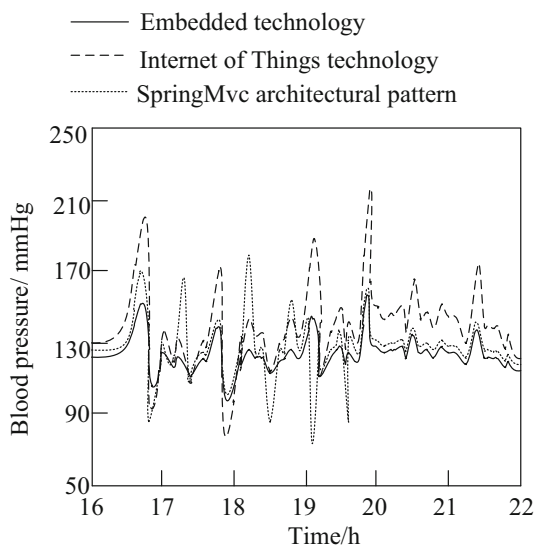

**Fig. 6.** Monitoring results of blood pressure data from three systems

It can be seen from Fig. 6 that the fluctuation range of human diastolic blood pressure in the system based on IoT technology is 75 mmHg–220 mmHg; The fluctuation range of diastolic blood pressure in the system based on SpringMvc architecture mode is 65 mmHg–190 mmHg; The fluctuation range of diastolic blood pressure in the system based on embedded technology it is 100 mmHg–160 mmHg, and the data obtained by using this system is consistent with the actual data. It can be seen that the blood pressure data monitoring results of the system based on embedded technology are accurate.

### Blood Oxygen Data Analysis

The blood oxygen data monitoring results of the three systems are shown in Fig. 7.

It can be seen from Fig. 7 that the blood oxygen measurement values of the system based on the Internet of Things technology are 85%, 83%, 89%, 85%, 87%, 84% and 93%, respectively, and there is a maximum error of 8% with the actual data; The measured values of blood oxygen in the system based on the SpringMvc architecture mode are 86%, 88%, 99%, 95%, 91%, 93% and 95% respectively, and there is a maximum error of

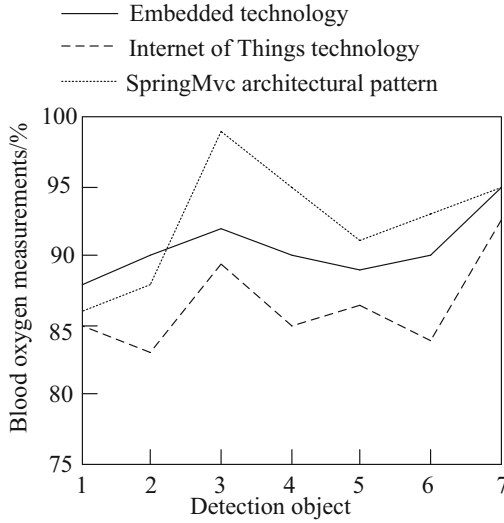

Fig. 7. Monitoring results of blood oxygen data in three systems

7% with the actual data; The system blood oxygen measurement values are 88%, 90%, 92%, 90%, 89%, 90% and 95% respectively, and there is only a maximum error of 1% with the actual data. It can be seen that the monitoring results of blood oxygen data of the system based on embedded technology are accurate.

The pulse rate data monitoring results of the three systems are shown in Fig. 8.

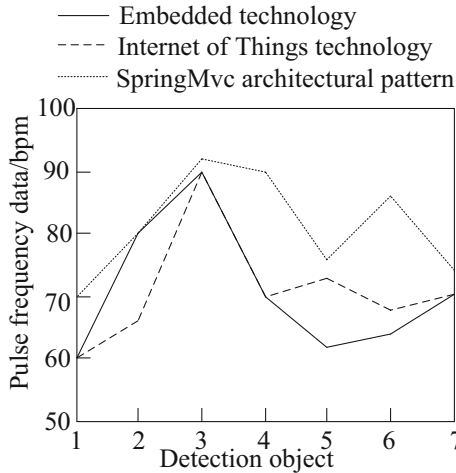

Fig. 8. Monitoring results of pulse rate data for three systems

Figure 8 shows that the system pulse rate data based on IoT technology are 60 bpm, 66 bpm, 90 bpm, 70 bpm, 62 bpm, 64 bpm and 70 bpm respectively, and there is a

maximum error of 8% with the actual data; using the system pulse rate data based on the SpringMvc architecture mode 70 bpm, 80 bpm, 92 bpm, 90 bpm, 76 bpm, 96 bpm, and 74 bpm, respectively, with a maximum error of 7% from the actual data; the system pulse rate data based on embedded technology are 60 bpm, 80 bpm, 90 bpm, 70 bpm, 62 bpm, 64 bpm, respectively and 70 bpm, the data obtained by using this system is consistent with the actual data, it can be seen that the monitoring results of pulse rate data based on embedded technology are accurate.

## 6 Conclusion

- (1) The designed telemedicine and health care system based on embedded technology can easily and accurately collect and process the basic physiological information of the human body, provide the online doctors with physiological data information, realize the interaction between users and doctors, make people conveniently and quickly get their own health information, facilitate health care prevention and early treatment, and to a certain extent, realize the self diagnosis information for reference.
- (2) The idea of using embedded technology to develop software makes the system easy to maintain and upgrade, reduces the development cycle of products, reduces the development cost of the system, and improves the cost performance of the system, so that the telemedicine service can go to the market, enter the home, serve more people, and provide an effective design scheme for the design of the home telemedicine system.
- (3) However, in the process of experimental verification, the response time of the system was not verified, and the response time of the system is closely related to user satisfaction. The verification of the system is not comprehensive, and there are certain limitations. Therefore, the next step needs to verify the response time of the system, to further optimize the comprehensive performance of the system in this respect, and promote the wide application of the system in practice.

## References

1. Keke, G., Yang, Z., Xu, D.: Design of remote home medical system based on springmvc architecture mode. *Packa. Eng.* **41**(04), 160–165+176 (2020)
2. Qu, J., Li, Y.: An authentication protocol for telecare medicine information system. *J. Wuhan Univ. Nat. Sci. Ed.* **66**(02), 117–125 (2020)
3. García-Villena, J., Torres, J.E., Aguilar, C., et al.: 3D-printed portable robotic mobile microscope for remote diagnosis of global health diseases. *Electronics* **10**(19), 2408–2420 (2021)
4. Huang, H.W., Hsu, W.Y., Lee, C.H., et al.: Development of a light-weight deep learning model for cloud applications and remote diagnosis of skin cancers. *J. Dermatol.* **48**(3), 310–316 (2021)
5. Ac, A., MI, B., Sm, A.: Applying telemedicine for stroke remote diagnosis: the telestroke system. *Procedia Comput. Sci.* **198**(1), 164–170 (2022)
6. Qin, L., Zhang, R.: Mobile medical system design based on behavior design. *Pack. Eng.* **42**(22), 191–203 (2021)

7. Tong, W., Hou, Z., Zeng, S., et al.: Design of positioning and remote control system based on NB-IoT. *Inst. Techn. Sensor* (10), 94–97+119 (2021)
8. Wang, D., Li, C., Sun, J., et al.: Discussion on the clinical value of ultrasonic artificial intelligence diagnosis system combined with telemedicine. *Chin. J. Ultrasound Med.* **37**(07), 765–766 (2021)
9. Chen, X., Yue, W.: Exploration on mobile terminal guidance service design in smart healthcare system. *Pack. Eng.* **41**(12), 143–149 (2020)
10. Li, T., Yan, F., Yu, Z., et al.: The design and application of remote monitor data acquisition system based on ARM. *Electric Drive* **50**(07), 103–107 (2020)
11. Liu, Z., Liu, J.: Accurate test simulation of operation stability and performance of wireless medical monitoring system. *Comput. Simul.* **36**(4), 375–378 (2019)
12. Wei, W., Xin, Z., Wang, S., Zhang, Y.: Covid-19 diagnosis by WE-SAJ, systems science & control. *Engineering* **10**(1), 325–335 (2022). <https://doi.org/10.1080/21642583.2022.2045645>
13. Huang, C., Wang, W., Zhang, X., Wang, S.-H., Zhang, Y.-D.: Tuberculosis diagnosis using deep transferred EfficientNet. *IEEE/ACM Trans. Comput. Biol. Bioinf.* (2022). <https://doi.org/10.1109/TCBB.2022.3199572>
14. Lin, H.C., Chou, F.Y., Hong, Y.X., et al.: Fast elevator vibration signal cloud collection system using data compression and encryption algorithms. *Sens. Mater. Int. J. Sensor Technol.* **34**(Pt.4), 2311–2324 (2022)
15. Li, J.: Research on safe transmission of broadband fm laser signal based on particle swarm optimization algorithm. *Laser J.* **42**(7), 118–121 (2021)