



Speed Control of BLDC Motor Using Bi-directional Converter

B. Raja Gopal Reddy¹, N. Karupiah¹, Patil Mounica¹(✉), Jaydeep Kumar²,
and Keval Jitendrabhai Dasadiya²

¹ Vardhaman College of Engineering, Hyderabad, India
{b.rajagopalreddy,mounica.p}@vardhaman.org

² RK University, Rajkot, India
Jaydeep.parmar@rku.a.c.in

Abstract. The environmental pollution is enlarging due to the existence of a greater number of gasoline vehicle. Electric vehicles are highly important to reduce pollution, and they are the best option when compared to conventional automobiles. Since they offer higher power densities, superior speed-torque characteristics, maximum efficiency, wide speed ranges, and require less maintenance, brushless DC motors are a viable option for electric cars. This paper uses a bidirectional DC-DC converter to regulate the speed of the BLDC motor. Bidirectional DC-DC converters are frequently used for battery charging and discharge. The buck boost mode of bidirectional converter is an option. The battery's energy reserves give the Brushless DC motor its full power, whilst the same bidirectional buck as well as boost converter returns energy to the source during regenerative braking.

Keywords: BLDC Motor · Buck-Boost converter · PID controller

1 Introduction

Electric vehicles (EV), commercial use, manufacturing turbines, and especially aerospace industries are a few common uses for brushless DC (BLDC) motors [1]. Because of their quick response times, high power factors, silent operation, compact size, reliability, high efficiency, and cheap maintenance costs, brushless DC motors are used extensively. Since they are electronically commutated, BLDC motors do not require brushes for commutation. This motor generates a quasi-rectangular square waves with a trapezoidal back EMF. A permanent-magnetic synchronous motor with a trapezoidal emf waveform is frequently referred to as a "BLDC motor." As its name suggests, BLDC motors do not employ brushes for transmission; instead, they use electronics [2–4].

BLDC motors have such a variety of benefits over brushed DC motors. Because of electromechanical commutator is just no longer required, they require less maintenance, and they are perfect for applications requiring a high torque-to-weight proportion because to their high power density. Compared to the induction machines, they also have less

inertia, allowing for a quicker dynamic response to reference commands. They are also more efficient due to an electromagnets, which virtually completely eliminate rotor losses [5–8].

The buck boost converter supplied with PI controller is another name for the bidirectional dc-dc converter. The bidirectional DC-DC converter offers two operational modes: Boost (increasing voltage from a low level to a higher level) and Buck (decreases the voltage from high level to low level) [9–13].

2 Bidirectional DC-DC Converter

The Bidirectional DC-DC Converter module illustrates a converter that is powered by a controller and signal generator to increases or decreases the DC voltage is applied from one converter side to the other. For instance, bidirectional converters can be used in electric automobiles to transition among energy storage and consumption (Fig. 1).

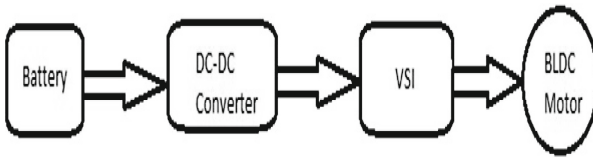

Fig. 1. Overall Block Diagram

The use of MOSFETs or IGBTs to change the current’s state rather than all diodes is the key difference between a bidirectional DC - DC converter and also unidirectional DC - DC converter. The bi-directional DC DC converter may still function as a Buck converter by lowering the voltage from a higher level to a lower level as well as a Boost converter by raising the voltage from a lower level to a higher level, depending on the amount of current and voltage being generated along with the location of the energy storage items (Fig. 2).

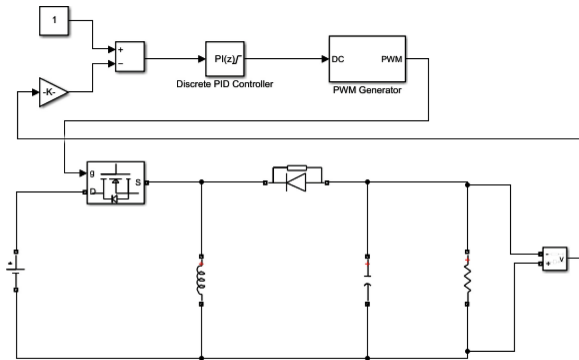

Fig. 2. Bidirectional DC-DC Converter

An example of a DC-DC converter is a “buck-boost converter”, which has an output voltage magnitude that can be either more than or lower than the input voltage magnitude. It is utilized by “step up” incoming DC voltage, just like an AC transformer would.

3 Brushless DC Motor

An electronically commutated motor, often known as a brushless DC electric motor, is a synchronous motor that uses a direct current (DC) power supply. The motor windings, which are effectively made to rotate in space by switching DC currents to them, produce magnetic fields that the permanent magnet rotor follows. The controller alters the DC current pulses’ phase and amplitude to control the motor’s speed and torque. With this control system, the mechanical commutator present in many common electric motors can be swapped out. These motors can provide a lot of power over a wide range of speeds extremely effectively. Brushless motors utilise a fixed armature with permanent magnets, which takes care of the problem of feeding the armature with current. Transportation based on electronics gives a wide range of options and adaptability (Fig. 3).

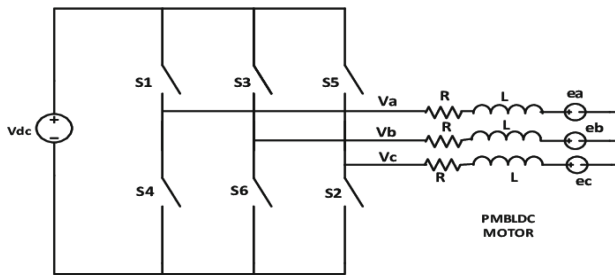

Fig. 3. Circuit of Brushless DC Motor

The use of brushless DC (BLDC) motors is widespread in a variety of industries, including automotive, computing, industrial, and aerospace. Compared to brushed DC motors, BLDC motors provide a number of benefits. They are ideal for applications needing very high torque-to-weight ratio because to their high power density also low maintenance requirements due to the absence of a mechanical commutator. They have less inertia than induction machines, which enables a quicker dynamic reaction to reference commands. Additionally, they have nearly no rotor loss because of the permanent magnets’ increased efficiency.

3.1 Mathematical Model of Brushless DC Motor

The electrical as well as mechanical mathematical equations of the BLDC motor are:

$$V_p = Ri_p + L \frac{di_p}{dt} + e_p \quad (1)$$

$$V_q = Ri_q + L \frac{di_q}{dt} + e_q \quad (2)$$

$$V_r = Ri_r + L \frac{di_r}{dt} + e_r \quad (3)$$

where,

V_p, V_q, V_r = Terminal phase voltage

R = Armature resistance

I_p, I_q, I_r = Phase Currents

L = Phase Inductance

e_p, e_q, e_r = Phase Back EMF

We can plot this induced emf as a parameter of rotor position for a three-phase BLDC motor, and it is obvious that there is a 120° change in the phase angle of the in-phase back EMF

$$e_p = k_w \omega f (\theta_e) \quad (4)$$

$$e_q = k_w \omega f \left(\theta_e - \frac{2\pi}{3} \right) \quad (5)$$

$$e_r = k_w \omega f \left(\theta_e + \frac{2\pi}{3} \right) \quad (6)$$

where,

K_w = induced emf

θ_e = Torque angle

ω = Speed of the Rotor

The total of the torque outputs from each phase can be used to represent the overall torque. The following equation shows the overall torque output:

$$T_e = \frac{e_{pi_p} + e_{qi_q} + e_{ri_r}}{\omega} \quad (7)$$

4 Four Quadrant Operation

The motor has the ability to break and move forward as well as backward. Since a DC motor may run in both directions of revolution and generate both motoring and braking, it is known as having four quadrant action (Fig. 4).

The machine transforms electrical power into mechanical power to sustain motion when it is in driving mode, acting as a motor. When the machine is braking, it functions as a generator, converting mechanical energy into electrical energy and creating an opposing force to motion. The motor has the ability to operate in both driving and braking actions, or perhaps both forward again and backward motion.

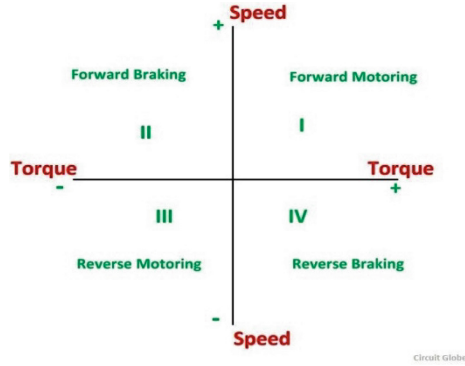

Fig. 4. Four Quadrant

5 Circuit Description and Simulation Results

Figure 5 shows the functional circuit of speed control of BLDC electric motor with the help of PID controller. The Simulink model is composed of an inner loop for current control as well as an outer speed feedback control. PI controller is used to implement the current control loop. PID controllers are used in the outer speed feedback loop.

Figure 5 shows speed control of Brushless DC electric motor, there are three main circuits named BLDC motor model block, Bidirectional DC-DC converter circuit which uses PI controller and Speed control circuit which uses PID controller.

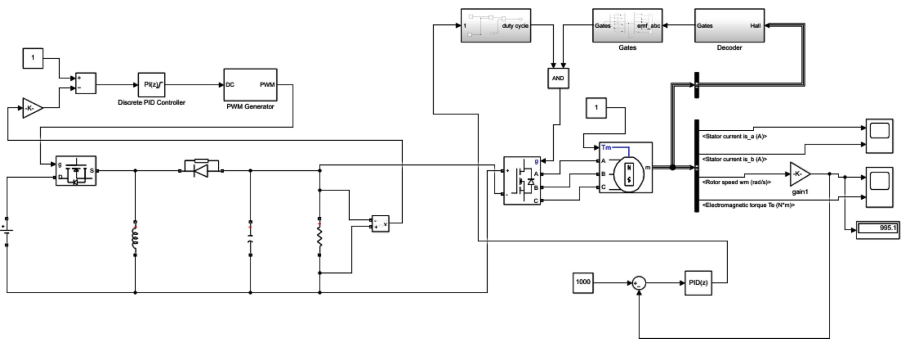

Fig. 5. Simulation figure of the proposed speed control of Brushless DC motor with the help use of Bidirectional converter

Figure 6 uses a PI controller to demonstrate the rotor speed and electromagnetic torque outputs of the Brushless DC motor.

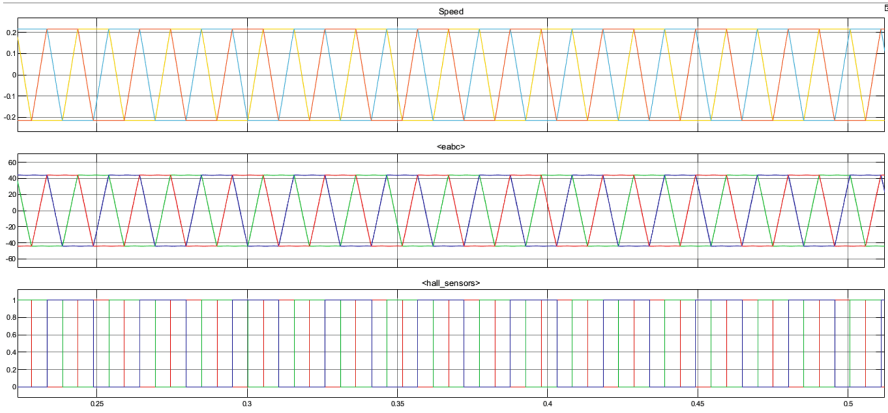

Fig. 6. Rotor speed and Torque

Figure 7 shows overall field winding current of a brushless DC motor.

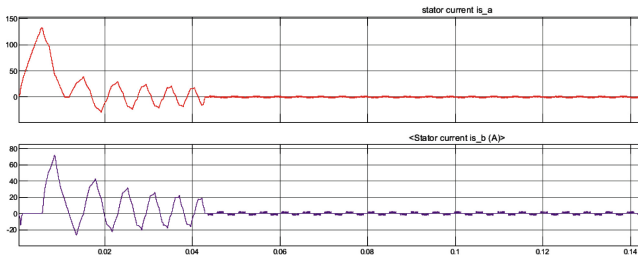

Fig. 7. Stator Currents

Figure 8 gives the speed of brushless DC motor which is 2000 rpm and matches with the actual rating of the motor.

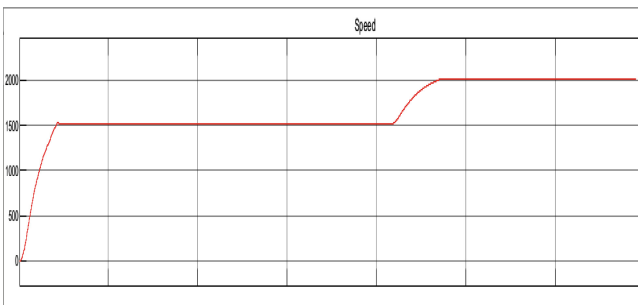

Fig. 8. Speed of Brushless DC motor

6 Conclusion

In this project, the functionality of the BLDC motor's controller is verified under various load conditions using simulation and a PI controller. Here, the motor speed is managed by the controlled voltage of a bidirectional dc-dc converter. Multiple trigger gate signals are produced under various circumstances. The dynamic characteristics, such like speeds, voltage, and also electromagnetic Torque, can be examined with the help of MATLAB/SIMULINK software. Simulation findings show enhanced performance whenever the suggested control is applied under various operating situations.

References

1. Ravivarman, S., Natarajan, K., Raja Gopal, R.B.: Non-isolated Modified Quadratic Boost Converter with Midpoint Output for Solar Photovoltaic Applications. *E3S Web Conf.* **87**, 01025 (2019)
2. Suganthi, P., Nagapavithra, S., Umamaheswari, S.: Modeling and Simulation of Closed Loop Speed Control for BLDC Motor. *Proc. IEEE Conference on Emerging Devices and Smart Systems [4]* Ramachandran R, Ganeshaperumal D, Subathra B "Closed-loop Control of BLDC Motor in Electric Vehicle Applications"
3. Ismail, M., Majumdar, S., Albadri, S.S., Jayaram, K.: Simulation and analysis of closed loop speed control of brushless DC motor. *International Journal of Advanced Information Science and Technology (IJAIST)* (2014)
4. Mukherjee, P., Sengupta, M.: Closed loop speed control of a laboratory fabricated Brush-less DC Motor drive prototype using position sensor. *2017 National Power Electronics Conference (NPEC)*
5. College of Engineering Pune. India (2017)
6. Rajesh, G., Balaji, C.: Speed Control of BLDC Motor Using PID Controller. *International Journal of Advanced Research in Electrical, Electronics and Instrumentation Engineering (An ISO 3297: Certified Organization)* (2007)
7. Neethu, U., Jisha, V.R.: Speed control of brushless DC motor: a comparative study. *2012 IEEE International Conference on Power Electronics, Drives and Energy Systems* (2012)
8. Ananthababu, B., Ganesh, C., Pavithra, C.V.: Fuzzy based speed control of BLDC motor with bidirectional DC-DC converter. *2016 Online International Conference on Green Engineering and Technologies*
9. Lin, C.-H., Liu, H.-W., Wang, C.-M.: Design and implementation of a bi-directional power converter for electric bike with charging feature. *Industrial Electronics and Applications (ICIEA), 2010 the 5th IEEE Conference on.* IEEE (2010)
10. Kumar, R., Singh, B.: Buck-boost converter fed BLDC motor drive for solar PV array based water pumping. *IEEE International Conference on Power Electronics, Drives and Energy Systems (PEDES)*, pp. 1–6 (2014)
11. Li, Y., Ang, K.h., Chong, G.C.G.C.Y.: PID control system analysis and design. *IEEE Control Systems Magazine* **26**(1), 32–41 (2006)
12. Lee, W., Kim, J.H., Choi, W., Sarlioglu, B.: Torque ripple minimization control technique of high-speed single phase brushless DC motor for electric turbocharger. *IEEE Transactions on Vehicular Technology* **67**(11), 10 357–10 365 (2018)
13. Low, T., Chen, S., Gao, X.: Robust torque optimization for BLDC spindle motors. *IEEE Transactions on Industrial Electronics* **48**(3), 656–663 (2001)