



# High Reliability Design of Student Status Information Acquisition System in Ideological and Political Classroom Under Multi-target Tracking

Gui-xiu Xie<sup>1</sup> (✉) and Tao Lei<sup>2</sup>

<sup>1</sup> Guangdong Polytechnic College, Zhaoqing 526100, China  
xx210428@163.com

<sup>2</sup> Physical and Electronic Engineering School, South China Normal University,  
Guangzhou 510006, China

**Abstract.** Aiming at the low reliability of the traditional ideological and political classroom student status information acquisition system, a high-reliability design of the ideological and political classroom student status information acquisition system under multi-target tracking is proposed. Under multi-objective tracking, the hardware design of the system is completed by designing the student status information storage module in the ideological and political classroom, designing the student status information analysis processor in the ideological and political classroom, and designing the student status information query module in the ideological and political classroom. By extracting the ontology of student status information in ideological and political classrooms and designing a program for obtaining student status information in ideological and political classrooms, the software design of the system has been completed and the acquisition of student status information in ideological and political classrooms has been achieved. The experimental results show that the ideological and political classroom student status information acquisition system under multi-target tracking has higher reliability in terms of accuracy, usefulness and recall.

**Keywords:** Multi-target tracking · Ideological and political class · Student status · Access to information · High reliability

## 1 Introduction

In recent years, with the development of education in colleges and universities, it is urgent to introduce advanced management technology of student status information, improve the level of education, improve the efficiency of obtaining student status information, so as to consolidate the comprehensive competitiveness of university education. In the daily operation of colleges and universities, the acquisition of student status information is a crucial task, and it is also a direct reflection of the level of Ideological and

political classroom management, which determines the quality and social image of Ideological and political classroom education in Colleges and universities. Therefore, how to actively introduce appropriate information technology and build a university student status information management platform is a key issue related to the development of university education [2].

In the United States, Europe and other developed countries and regions, many universities with technical strength have participated in the development of student status information collection system of Ideological and political classroom, especially in some developed countries in North America and Japan. Software development agencies cooperate to develop a practical system suitable for college students' management needs [3]. Literature [4] predicts students' performance through online learning behavior analysis. In terms of the development mode of the student status information collection system in the ideological and political classroom, most of the systems have developed from the original student status information collection system in the ideological and political classroom based on C/S mode to the current student status information collection system in the ideological and political classroom based on B/S mode, It realizes the integrated storage and distribution of data information, and the operability and concept of the system are gradually improving, which can greatly improve the efficiency and accuracy of the acquisition of student status information in the ideological and political classroom. It can realize data interconnection and information sharing with other systems. Literature [5] uses decision tree analysis to predict students' performance in higher education institutions. At present, in order to continuously improve the level and efficiency of student management, many foreign universities have joined some ERP design concepts to develop more systematic products. It can be seen that in many years of technology development and application practice, many foreign countries have accumulated rich experience in the development of the student status information collection system in the ideological and political classroom, and are still in the process of continuous improvement. It should be pointed out that the management mode of many foreign universities is different from that of China. Therefore, although the design concept and method can be used for reference in our country, it should be completely transformed into a system adapted to the students' environment in our country, rather than directly used [6].

The application of information technology in the acquisition of student status information in the ideological and political classroom of colleges and universities began in the late 1980s. Some qualified universities gradually apply the computer management mode to the acquisition of student status information in the ideological and political classroom [7, 8]. Many colleges and universities have begun to realize the efficiency and convenience brought by the management system based on information technology. Therefore, they began to deploy a more powerful and better performance student status information collection system [9] combined with their own internal network. Chinese universities can also be divided into different types. Different types of colleges and universities have their own characteristics and needs of obtaining student status information, so there is no general system to meet the needs for obtaining student status information of all colleges and universities [10–12].

Therefore, this paper proposes a high reliability design of the student status information acquisition system in the ideological and political classroom under multi-target

tracking. By using multi-target tracking algorithm, the state information of students in Ideological and political class is obtained, and its reliability is analyzed. Experiments show that the system can further improve the level of information management in colleges and universities, improve the status of teaching management. This is of great significance for strengthening the management of college students and providing a more stable and safe campus environment.

## 2 The Hardware Design of the Student Status Information Acquisition System in Ideological and Political Classroom

Under multi-target tracking, cloud computing is introduced to design the hardware of the student status information acquisition system. Cloud computing is a brand-new network service method that improves the traditional desktop-centric task processing method and transforms it into a network-core task processing, the use of Internet technology to achieve rapid information transmission [13]. The design purpose of the cloud computing-based ideological and political classroom student status information acquisition system is to realize the voluntary expansion of the system, unified management and efficient

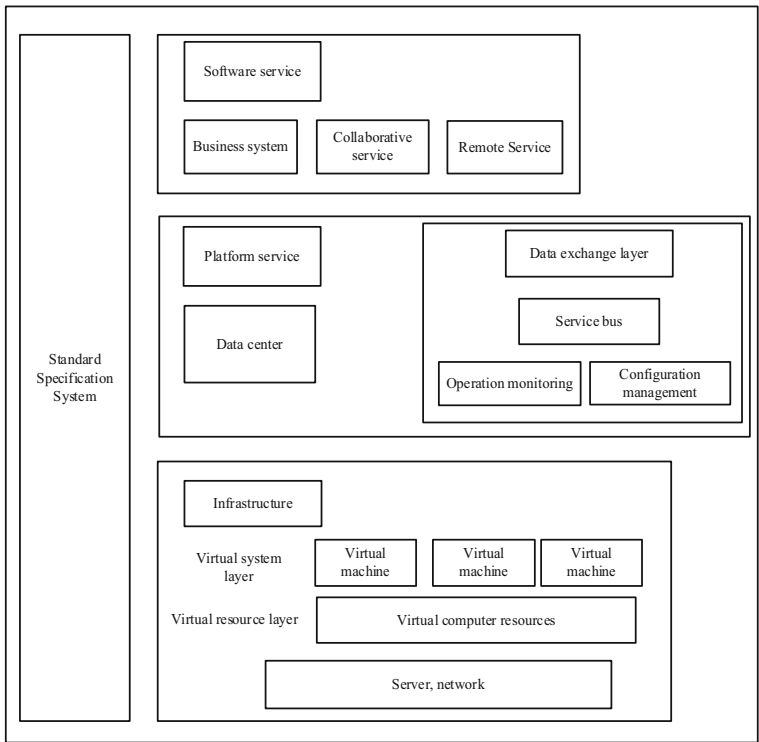
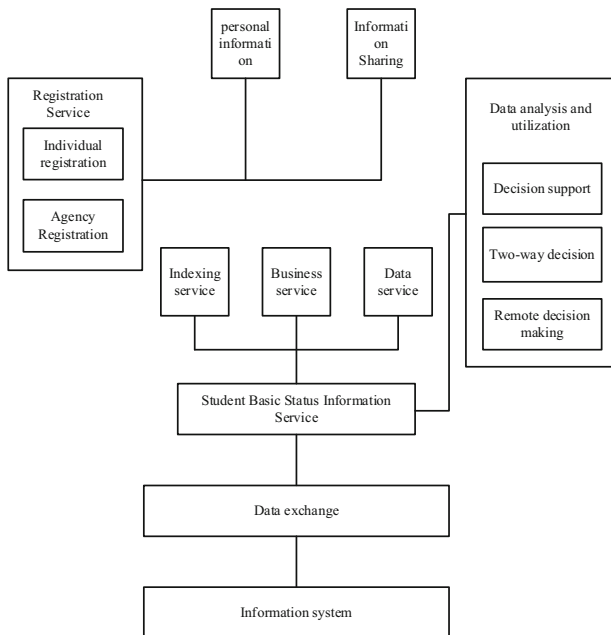

**Fig. 1.** Architecture diagram of student status information acquisition system in ideological and political classroom

query of large amounts of data [14]. The system is designed according to big data goals and business requirements, and the specific architecture is shown in Fig. 1.

It can be seen from Fig. 1: According to system requirements, the student status information acquisition system for ideological and political classrooms must be designed in a cloud computing environment. Business management expansion and horizontal expansion of system storage capacity can be carried out. Therefore, the ideological and political classroom student status information acquisition system designed with the concept of cloud computing has the advantage of large capacity, which can accommodate a large amount of ideological and political classroom student status information [15].

According to the overall system architecture, the system hardware structure is designed, as shown in Fig. 2.



**Fig. 2.** The hardware structure diagram of the student status information acquisition system in the ideological and political classroom

It can be seen from Fig. 2 that the overall architecture of the student status information acquisition system in the ideological and political classroom is composed of the institutional layer and the platform layer. Among them: the institutional layer includes the information system, which is the main source of student status information in the ideological and political classroom. The platform layer is a data exchange platform with functions such as basic information services, registration services, information sharing services, and data analysis.

### 2.1 Ideological and Political Classroom Student Status Information Storage Module Design

Traditional ideological and political classroom student status information storage adopts a centralized serial storage method. The state information of students in ideological and political classrooms stored in this way is limited, and it is difficult to store the state information of students in ideological and political classrooms [16]. The multi-target database is the sum of the dynamic information related to the application on the physical storage medium of the system, and usually exists on the medium in a fixed structure.

For the storage of student status information in ideological and political classrooms under multi-target tracking, the cloud computing environment should be the center, and different devices should be connected to jointly complete the query of student status information in ideological and political classrooms. This process requires the establishment of a data center to store massive amounts of information in the server. This provides convenience for the analysis and processing of student status information in ideological and political classrooms. The structure design of student status information memory in ideological and political classrooms is shown in Fig. 3.

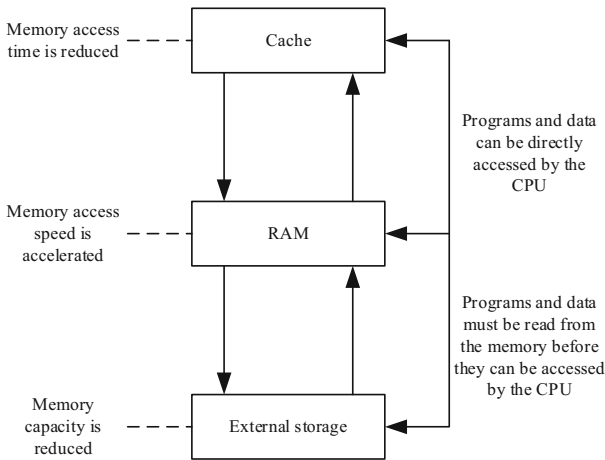
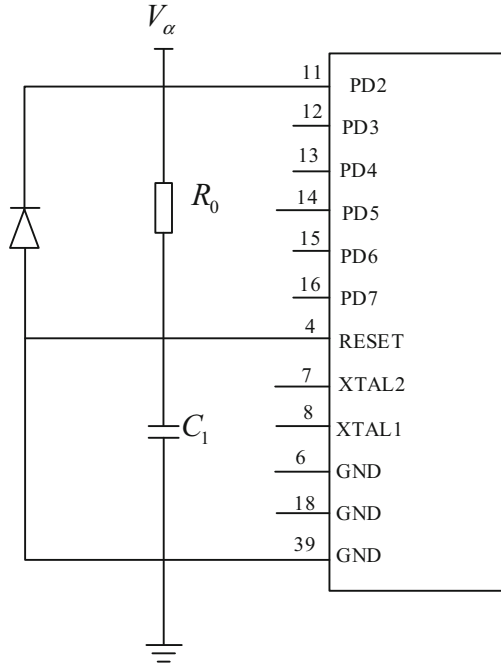

**Fig. 3.** Ideological and political classroom student status information memory structure diagram

It can be seen from Fig. 3: If there is a large amount of ideological and political classroom student status information, the information storage time will be greatly increased. Then it is necessary to increase the storage speed of student status information in ideological and political classrooms to ensure that the storage of dynamic information can save time. At this time, the stored state information of students in the ideological and political classroom can be directly accessed by the CPU. If the memory speeds up the storage of student status information in ideological and political classrooms, the internal fast conversion function needs to be used to convert the information into a memory form. At this time, the stored state information of students in the ideological and political classroom can be accessed by the CPU. If the mass information storage memory becomes smaller,

the information storage speed needs to be increased. The corresponding program is used to convert the data into the form of memory, and the data is accessed by the CPU through the cache [17].

The memory circuit diagram is shown as in Fig. 4.

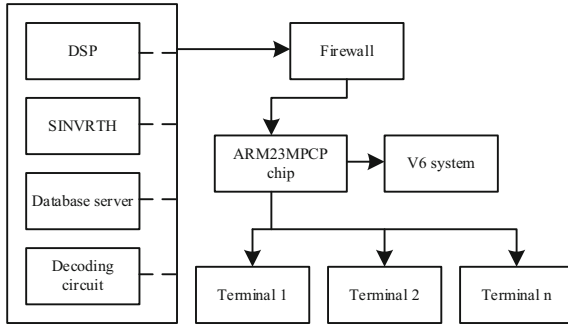

**Fig. 4.** Ideological and political classroom student status information memory circuit diagram

## 2.2 Ideological and Political Classroom Student Status Information Analysis Processor Design

This paper uses the ARM23MPCPR chip as the processor core. This chip is a new generation of V6 system processor chips based on the traditional ARM12. Different applications require different requirements. The processor can provide up to 6 combinations, and its performance can reach more than three times that of traditional processors. The processor structure is shown in Fig. 5.

It can be seen from Fig. 5 that the given processor is a relatively standard multi-core processor. The processor is composed of 4 independent cores of the traditional ARM12, which can improve performance without changing the frequency, except for this advantage. In addition, the other various application indicators of this processor are very good, suitable for most of the electronic system requirements on the market now, while still operating normally, there is still room to provide multiple multimedia functions [18]. In various application environments, this processor can show high performance and

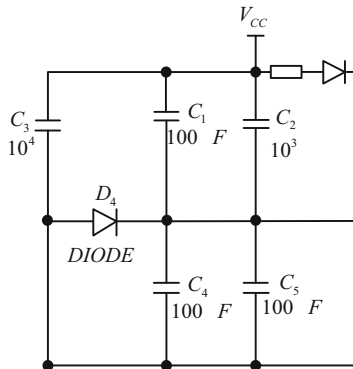

**Fig. 5.** The structure of the processor for analyzing the status of students in the ideological and political classroom

absolute advantages. The ARM23MPCPR chip can provide a multi-channel structure and support a hybrid system. This design greatly improves the flexibility, adaptability, and throughput of the processor. And computing power to meet various needs.

In terms of application, most manufacturers use traditional DSP and decoding circuits to implement encoding and decoding, and mainly use a single-core processor to complete the operation in the process. Although this method can decode efficiently, it has a large energy consumption problem. The architecture of this processor is a single-core architecture, which is similar to a single-core processor, but it is far superior to a single-core processor in terms of performance, including energy consumption and resource storage [19]. This processor incorporates the advantages of the Corntp-65 processor, uses the latest ARM architecture and V8 system, and integrates 4 72-bit storage units and processing units. It has very smooth acceleration performance and great flexibility.

The processor circuit diagram is shown as in Fig. 6.



**Fig. 6.** The circuit diagram of the processor for analyzing the status of students in ideological and political classroom

### 2.3 Ideological and Political Classroom Student Status Information Query Module Design

According to the above-mentioned information analysis and processing results, the ideological and political classroom student status information query module is designed, as shown in Fig. 7.

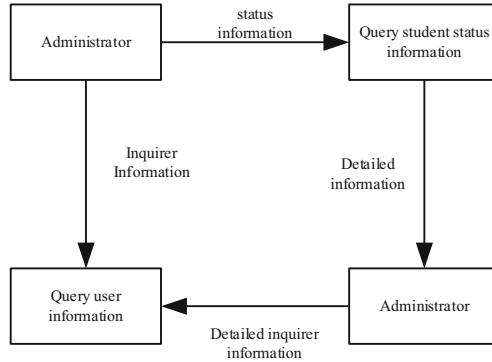

Fig. 7. Query module of student status information in ideological and political classroom

It can be seen from Fig. 7 that when the administrator wants to query the status information of the students in the ideological and political classroom, he needs to know the administrator's identity information first. In this process, the administrator's identity is verified, and it is determined whether it is a reader or an administrator. If it is an identity visitor, the identity information of the visitor needs to be known to facilitate the inquiry of the status information of the students in the ideological and political classroom.

The memory structure of student status information in the ideological and political classroom designed with multi-target tracking can save time. The internal fast conversion function is used to convert the student status information in the ideological and political classroom into a memory form, which is directly accessed by the CPU. The analysis and processing module analyzes certain historical records existing on the system and restores dormant files. According to the analysis and processing results of the student status information in the ideological and political classroom, the student status information query module in the ideological and political classroom is designed to ensure the safety of the system design.

## 3 Software Design of Student Status Information Acquisition System in Ideological and Political Classroom

### 3.1 Extraction of Student Status Information Ontology in Ideological and Political Classroom

In the process of designing the student status information acquisition system in the ideological and political classroom under multi-target tracking, the multi-target tracking

data is analyzed and processed first. The TF-IDF index of student status information in the ideological and political classroom is calculated based on the multi-target tracking data. The distribution model of student status information in the ideological and political classroom is established. On this basis, the ideological and political classroom student status information vector is calculated to extract the student status information ontology in the ideological and political classroom. The specific process is as follows:

Assume that  $K$  represents the subject collection of student status information in the ideological and political classroom searched by the user.  $M$  represents multi-target tracking data collection.  $N$  represents the number of ideological and political classroom student status information used in the multi-target tracking data.  $\alpha$ ,  $\beta$  represents a priori parameter. First, analyze and process the multi-target tracking data, filter the status information of students in ideological and political classrooms under multi-target tracking [20], and use Eq. (1) to calculate the TF-IDF index of student status information in ideological and political classrooms under multi-target tracking.

$$\text{TF}_{i,j} - \text{IDF}_i = \frac{f_{i,j}}{j} \times \log_2 \frac{N}{n_i} \quad (1)$$

$$\sum_{k=1} f_{k,j}$$

where: TF represents the frequency of student status information in ideological and political classrooms under multi-target tracking data. IDF represents the inverse document frequency of student status information in ideological and political classrooms under multi-target tracking data.  $n_i$  represents the state information of students in the ideological and political classroom under the multi-target tracking data  $i$  the behavior set that has occurred.  $j$  represents a certain status information record under the multi-target tracking data.  $f_{i,j}$  represents the number of times that the student status information  $i$  in the ideological and political classroom under the multi-target tracking data appears in  $j$ .  $f_{k,j}$  represents the number of times that the topic  $k$  searched under the multi-target tracking data appears in  $j$ . From the Dirichlet distribution with the prior parameter  $\alpha$ , extract the distribution model of student status information in the ideological and political classroom corresponding to each document  $M$  under the multi-target tracking data, and express it by formula (2):

$$\theta_m \sim \text{Dir}(\alpha), \quad m \in [1, M] \quad (2)$$

In formula (2):  $\theta_m$  represents the distribution model of student state information in the ideological and political classroom under the multi-target tracking data;  $\text{Dir}(\alpha)$  represents the Dirichlet distribution with the prior parameter  $\alpha$  under the multi-target tracking data. Assuming that  $n_m$  represents the number of information that appears in the user's  $m$  state, use Eq. (3) to calculate the probability of generating ideological and political classroom student state information in the user's entire state library:

$$p(z|\alpha) = \prod_{m=1}^M p(z_m|\alpha) = \prod_{m=1}^M \frac{\Delta(n_m + \alpha)}{\Delta(\alpha)} \quad (3)$$

In formula (3):  $\Delta$  represents the Laplacian operator;  $p(z_m|\alpha)$  represents the probability of generating state information for students in the ideological and political classroom

in the  $m$  state of the user. The distribution model corresponding to the student state information  $K$  of each ideological and political classroom under the multi-target tracking data is extracted from the Dirichlet distribution with the prior parameter  $\beta$ , and the calculation is carried out using Eq. (4):

$$\phi_k \sim \text{Dir}(\beta), \quad k \in [1, K] \tag{4}$$

In formula (4):  $\phi_k$  represents the distribution model of student state information in ideological and political classrooms under multi-target tracking data.  $\text{Dir}(\beta)$  represents the Dirichlet distribution with the prior parameter  $\beta$  under the multi-target tracking data. Use formula (5) to calculate the probability of generating state information for all ideological and political classroom students under multi-target tracking data:

$$p(w|z, \beta) = p(w'|z', \beta) = \prod_{k=1}^K p(w_{(k)}|z_{(k)}, \beta) \tag{5}$$

In formula (5):  $p(w'|z', \beta)$  represents the generation probability of student status information in ideological and political classrooms with a priori parameter of  $\beta$  under multi-target tracking data, and  $p(w_{(k)}|z_{(k)}, \beta)$  represents the generation probability of student status information  $k$  in ideological and political classrooms under multi-target tracking data analysis. (3) Formula (5) is analyzed to obtain the joint distribution of the state information of all ideological and political classroom students under the multi-target tracking data, which can be expressed by formula (6):

$$p(w, z|\alpha, \beta) = p(w|z, \beta)p(z|\alpha) \tag{6}$$

Assuming that  $Z_{m,n}$  represents the hidden content of student state information in the ideological and political classroom under the multi-target tracking data, combined with the distribution model of the student state information in the ideological and political classroom under the multi-target tracking data, the  $n$  ideological and political classroom corresponding to the multi-target tracking data  $m$  is calculated student status information is calculated using the following formula:

$$Z_{m,n} \sim \text{Mult}(\theta), \quad m \in [1, M], n \in [1, N_m] \tag{7}$$

$$W_{m,n} \sim \text{Mult}(Z_{m,n}) \tag{8}$$

In formula (8):  $W_{m,n}$  represents the amount of student status information acquired in the ideological and political classroom under the multi-target tracking data.  $\text{Mult}(Z_{m,n})$  represents the spatial threshold of the Multinomial conjugate distribution of the student state information distribution model in the ideological and political classroom under the user behavior data.  $\text{Mult}(Z_{m,n})$  represents the spatial threshold of the Multinomial conjugate distribution with an implicit content of  $Z_{m,n}$ . Combining the Gibbs sampling method to solve the hidden content  $Z$  of the student state information in the ideological and political classroom under the multi-target tracking data, extract the student state information samples in the ideological and political classroom, and calculate the weight under the multi-target tracking data.

### 3.2 Program Design for Acquiring Status Information of Students in Ideological and Political Classroom

After constructing the hardware system used in this paper, the software environment is set up. The basic operating system of the software processor is the Linux system. Using u-boot configuration, the software system can perceive the status information of students in the ideological and political classroom in real time. The interface shows the collected status information characteristics of the students in the ideological and political classroom.

The set software flow chart is shown in Fig. 8.

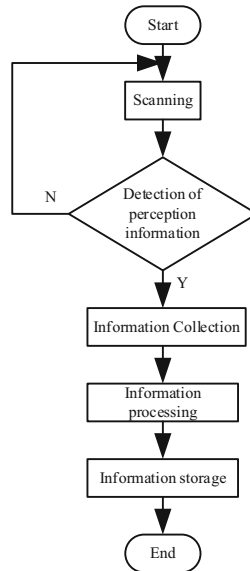

**Fig. 8.** Ideological and political classroom student status information acquisition program

It can be seen from Fig. 8 that the system software process designed in this paper is divided into three steps.

Step 1: Collect student status information in ideological and political classrooms. A variety of sensors are used to collect student status information in ideological and political classrooms, including learning information, behavior information, and action information. The information retrieved in the human-computer interaction interface is interacted with each other to achieve the purpose of auxiliary processing. Corresponding decision rules should be set during the collection process, and learning information, behavior information, and action information should be collected in a periodic manner. Multiple sensors are used to analyze whether the collected information meets the acquisition conditions. If the acquisition conditions are met, the acquisition service must be started, and if the acquisition conditions are not met, information collection cannot be performed. The collection period of behavior information is 5 s, and the collector has its

own buffer. The number of acquisition frames is diverse, and the data can be processed and stored.

Step 2: The collected information is processed. The collected ideological and political classroom student status information is processed. The effect of student status information in the ideological and political classroom has a direct impact on the effect of the system. When students are in different positions, their status is also different. Therefore, it can be judged whether the student is in the best condition by seeing the student's behavior.

Step 3: The results of student status information in the ideological and political classroom are stored. After the collected information is obtained, the collected information is stored in the memory. Useful information is selected for display. The storage system and the alarm system should be closely connected. Once the student's learning status is perceived to be poor, an alarm should be sounded immediately to remind students to take effective measures to improve their learning status.

In summary, a detailed design of the student status information acquisition system in the ideological and political classroom is carried out.

## 4 Experimental Comparative Analysis

### 4.1 The Purpose of the Experiment

In order to test the actual effect of the ideological and political classroom student status information acquisition system under this multi-target tracking, the method in this paper is compared with the traditional ideological and political classroom student status information acquisition system and the experimental results are analyzed.

### 4.2 Experimental Parameter Settings

The experimental parameters are set as shown in Table 1.

**Table 1.** Experimental parameters

Item	Parameter
Configuration software	U-boot
Operating Voltage/V	350
Operating current/A	200
System structure	Application layer, service layer, sensor layer
System functions	Data collection, data processing, information storage
Operating system	Linux 系统
Operating frequency/Hz	500
CPU memory/GB	12
Collection methods	Real-time collection

### 4.3 Results and Analysis

The traditional ideological and political classroom student status information acquisition system and the ideological and political classroom student status information acquisition system under multi-target tracking are used to carry out the design experiments of the student status information acquisition system in the ideological and political classroom. The two different acquisition systems are used to compare the accuracy of student status information acquisition in ideological and political classrooms, and the average absolute error MAE (%) is used as the accuracy comparison result to measure the student status information acquisition systems in different ideological and political classrooms, and the calculation is carried out using Eq. (9):

$$MAE = \frac{\sum_{i=1}^G |p_i - q_i|}{G} \tag{9}$$

In formula (9):  $p_i$  represents the system’s predicted scoring value for the obtained state information of the  $i$  ideological and political classroom student.  $q_i$  represents the actual scoring value of the obtained student status information of the  $i$  ideological and political classroom by the user.  $G$  represents the number of data in the ideological and political classroom student status information acquisition data set under multi-target tracking. The average absolute error of the acquisition of student status information in two different systems of ideological and political classrooms is compared, and the results are shown in Fig. 9.

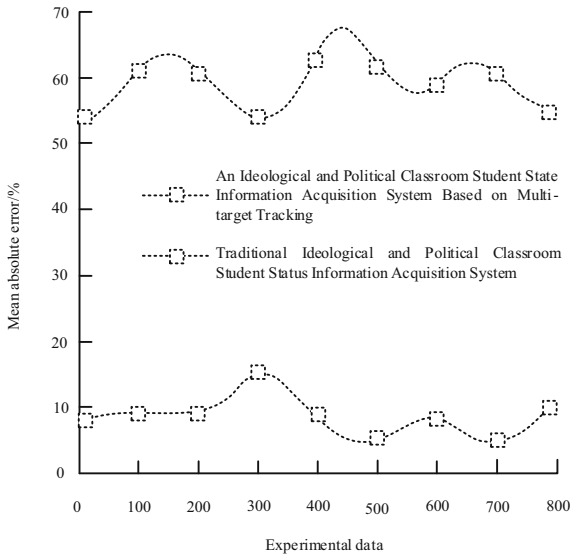

Fig. 9. Comparison results of average absolute error

Analysis of Fig. 9 shows that the average absolute error of using the ideological and political classroom student status information acquisition system under multi-target tracking to obtain the ideological and political classroom student status information is lower than that of the traditional ideological and political classroom student status information acquisition system. This is mainly because in the ideological and political classroom student status information acquisition system design process using the ideological and political classroom student status information acquisition system under multi-target tracking, the student status information in the ideological and political classroom is first analyzed and processed. The TF-IDF index of student status information in the ideological and political classroom under multi-target tracking is calculated. The Dirichlet distribution of the prior parameters is combined to establish the state information distribution model of ideological and political classroom students under multi-target tracking. Under multi-target tracking, the weight output of the student status information acquisition index in the ideological and political classroom is obtained. It makes the ideological and political classroom student status information acquisition system under multi-target tracking have a higher design accuracy for the ideological and political classroom student status information acquisition system under multi-target tracking.

The traditional ideological and political classroom student status information acquisition system and the ideological and political classroom student status information acquisition system under multi-target tracking are used to carry out the design experiments of the student status information acquisition system in the ideological and political classroom. The usefulness (%) and recall rate (%) of the two different systems for acquiring student status information in ideological and political classrooms were compared. Recall rate refers to the percentage of the total when users believe that the information obtained is useless. Usefulness refers to the degree of active availability of information acquisition. The comparison result is used to measure the comprehensive effectiveness of the information acquisition system design under the multi-target tracking of different systems. The comparison results are shown in Table 2 and Table 3.

**Table 2.** Comparison of usefulness of information acquisition systems under different systems (%)

Number of experiments/time	An ideological and political classroom student state information acquisition system based on multi-target tracking	Traditional ideological and political classroom student status information acquisition system
5	93.7	67.8
10	95.4	67.1
15	95.1	66.7
20	92.8	68.5
25	93.5	65.6
30	94.9	65.9

**Table 3.** Comparison of recall rates of information acquisition systems under different systems (%)

Number of experiments/time	An ideological and political classroom student state information acquisition system based on multi-target tracking	Traditional ideological and political classroom student status information acquisition system
5	7.1	22.6
10	6.8	20.7
15	7.0	19.6
20	6.6	19.9
25	6.9	21.5
30	7.3	20.9

Through the analysis of Table 2 and Table 3, it can be seen that the comprehensive performance of using the ideological and political classroom student status information acquisition system under multi-target tracking to obtain the student status information in the ideological and political classroom under multi-target tracking is higher than that of the traditional ideological and political classroom student status. Information acquisition system. This is mainly because in the process of acquiring information by using the ideological and political classroom student status information acquisition system under multi-target tracking, Internet users are abstracted as structured data information ontology. The  $n$ th state corresponding to the  $m$ th behavior of the user is calculated. The information ontology under the random behavior data of Internet users is extracted. On this basis, the user obtains the weight output of the information acquisition index by calculating the correlation between the query and the result record status information. The comprehensive performance of the student status information acquisition system in the ideological and political classroom under multi-target tracking is better.

## 5 Conclusion

This paper proposes a high-reliability design for the acquisition system of student status in ideological and political classrooms under multi-target tracking. Under multi-target tracking, the hardware and software of the student status information acquisition system in the ideological and political classroom are designed to achieve the acquisition of student status information in the ideological and political classroom. The results show that the information acquisition system designed in this paper has relatively high reliability, but in practical applications, the scalability of the system needs to be further studied.

## References

1. Liu, S., Liu, G., Zhou, H.: A robust parallel object tracking method for illumination variations. *Mob. Netw. Appl.* **24**(1), 5–17 (2018). <https://doi.org/10.1007/s11036-018-1134-8>

2. Xu, R., et al.: Towards emotion-sensitive learning cognitive state analysis of big data in education: deep learning-based facial expression analysis using ordinal information. *Computing* **102**(10), 765–780 (2019)
3. Farhan, M., et al.: IoT-based students interaction framework using attention-scoring assessment in eLearning. *Futur. Gener. Comput. Syst.* **79**, 909–919 (2018)
4. Zhang, W., et al.: Student performance prediction via online learning behavior analytics. In: 2017 International Symposium on Educational Technology (ISET), pp. 153–157. IEEE 2017
5. Hamoud, A., Hashim, A.S., Awadh, W.A.: Predicting student performance in higher education institutions using decision tree analysis. *Int. J. Intera. Multi. Artifi. Intellige.* **5**, 26–31 (2018)
6. Liu, S., Pan, Z., Cheng, X.: A novel fast fractal image compression method based on distance clustering in high dimensional sphere surface. *Fractals* **25**(4), 1740004 (2017)
7. Kuanglu, Y., et al.: Fast information acquisition using spectra subtraction for Brillouin distributed fiber sensors. *Optics express* **27**(7), 9696 (2019)
8. Sun, S., et al.: A distributed incremental information acquisition model for large-scale text data. *Clust. Comput.* **22**(1), 2383–2394 (2019)
9. Liu, S., et al.: Parallel Fractal Compression Method for Big Video Data. *Complexity* 2016976 (2018)
10. Sang, H., Zhou, Y., Zhou, G.: Interacting multiple models integrated tracking splitting target tracking method. *Command Control & Simulation* **42**(2), 38–45 (2020)
11. Yang, H., et al.: Object tracking algorithm based on discriminative correlation filter and depth information. *J. Chinese Comp. Sys.* **41**(4), 736–740 (2020)
12. Ma, J., et al.: Target tracking method based on fusion of human structural features and kernelized correlation filter algorithm. *J. Comp. Appl.* (S01), 56–60 (2020)
13. Ming, Z., et al.: A performance based method for information acquisition in engineering design under multi-parameter uncertainty. *Information Sciences* (2020)
14. Li, H., et al.: Design and optimization of a hybrid sensor network for traffic information acquisition. *IEEE Sensors Journal* **20**(4), 2132–2144 (2020)
15. Chen, X., Li, J., Sui, Y.: A new stitching method for dark-field surface defects inspection based on simplified target-tracking and path correction. *Sensors* **20**(2), 448 (2020)
16. Lia, J., Wang, Z., Xu, M.: DeepMTT: a deep learning maneuvering target-tracking algorithm based on bidirectional LSTM network. *Information Fusion* **53**, 289–304 (2020)
17. Xu, X., et al.: Research on key technologies of smart campus teaching platform based on 5G network. *IEEE Access* **7**, 20664–20675 (2019)
18. Sharma, P., et al.: Decentralized gaussian filters for cooperative self-localization and multi-target tracking. *IEEE Trans. Signal Processing*, 67 (2019)
19. Wei, X., Jing, L.: Data transmission and real-time information acquisition based on fine-grained algorithm and wireless network. *Peer-to-Peer Netw. Appl.* **13**(2), 1–11 (2019)
20. Ullah, I., et al.: Multisensor-based target-tracking algorithm with out-of-sequence-measurements in cluttered environments. *Sensors* **18**(11) (2018)