



# Design of Agricultural Network Information Resource Sharing System Based on Internet of Things

Kun Wang<sup>(✉)</sup>

Jiangsu Agriculture and Animal Husbandry Vocational College,  
Taizhou 225300, China  
wangkun010@tom.com

**Abstract.** Under the environment of Internet of things, agricultural network information service is open and resource sharing. In order to improve the intelligence of agricultural network information service under the environment of Internet of things, an agricultural network information resource sharing system based on Internet of things is constructed. The overall design description and function modularization analysis of agricultural network information resource sharing system are carried out. The system design includes agricultural network information service resource retrieval module, agricultural network information resource integration processing module, bus control module, resource information fusion module, program loading and compilation module and human-computer interaction module. The bottom module of agricultural network information resource sharing system is designed by using B/S architecture protocol and bus server system, the retrieval of massive agricultural network information service resources is designed based on Internet of things technology, the information dispatching network center of agricultural network information service resources is established under the environment of Internet of things technology, and the Internet of things networking design of agricultural network information resource sharing system is carried out by using network networking methods such as ZigBee and GPRS. The process management and file configuration are carried out under MVB bus control protocol, and the software development and design of agricultural network information resource sharing system are realized under embedded ARM environment. The test results show that the information resource sharing system of agricultural network based on Internet of things technology has good human-computer interaction and resource scheduling, and the execution time cost is small and the reliability is high.

**Keywords:** Internet of things · Agricultural network · Information resources · Sharing system

## 1 Introduction

With the continuous progress of science and technology, Internet of things technology is widely used in the sharing of modern agricultural network information resources, especially in the field of agricultural network information service, complex network

technology and wireless sensor network technology, the construction of agricultural network information resource sharing system, the use of network control method to realize the agricultural network information service under the Internet of things technology, and the use of new media to promote the improvement of agricultural network information service. So as to provide a better platform for the development of agricultural network information service in China [1]. Under the condition of Internet of things technology, the agricultural network information service platform is constructed, the agricultural network information service resource information is integrated, the agricultural network information agricultural network information resource information sharing level is improved, the communication among various regions is promoted, the agricultural network information service is upgraded in the process of globalization, and the design method of agricultural network information platform under the new media is studied. It is of great significance to improve the intelligent level and automatic control level of agricultural network information service [2].

The design of intelligent independent agricultural network information resource sharing system is based on the network design and software design of the platform, and the transmission and sharing of agricultural network information resources through network and modern media. By using wireless communication technology, Internet technology and Internet of things technology, the network control and resource optimization transmission of agricultural network information service can be realized. The design model of agricultural network information resource sharing system mainly adopts ITU-T H.323 and IETF SIP network signaling control scheme and (Real Time Control Protocol, RTCP), a real-time transmission control protocol for service quality monitoring, to realize the design of agricultural network information service [3], and obtains better platform automatic control efficiency.

In reference [4], an application program development model of agricultural network information resource sharing system based on Linux kernel control is proposed. The platform is developed and designed by using signaling technology, media coding technology and media real-time transmission technology. The information fusion transmission is carried out through ZigBee and wireless communication technology in the network layer, and the output control of agricultural network information service information data is carried out by using VXI bus technology. However, the real-time output performance of media information in this system is not good. In reference [5], a design model of agricultural network information resource sharing system based on VME bus architecture is proposed. The output control of agricultural network information service resource is realized by using the communication bus between special modules, and the original agricultural network information service information is sampled by sensor equipment, RFID label equipment and video equipment, so as to improve the intelligent control ability of agricultural network information service. However, the feedback output error of the system designed by this method is large. In reference [6], an agricultural network information resource sharing system based on TCP/IP is proposed. The non-contact RFID technology is used to activate the electronic label, which realizes the feedback control of the agricultural network information resource sharing system and improves the stability of the platform. The system is prone

to errors in process management and file configuration. In reference [7], a design model of agricultural network information resource sharing system based on Internet technology is proposed. The network transmission protocol under the mode of Internet of things is constructed by TCP/IP server or UPD server, and the agricultural network information resource sharing system is designed by using wireless sensor design. The independent control performance of the platform is not good [7].

In view of the above problems, this paper proposes an agricultural network information resource sharing system based on Internet of things. Firstly, the overall framework design and function modular analysis of the platform are carried out, the information processing core control module is then constructed, and the information fusion and integrated dispatching design of the agricultural network information service resources is carried out, the network networking design of the mass agricultural network information service resource retrieval design and the platform is carried out under the Internet of things environment, the software development design of the agricultural network information resource sharing system is realized under the MVB (multivibrator) bus control protocol and the embedded environment, and finally, the simulation experiment analysis is carried out. The advantages of the method in improving the control performance and information transmission capability of the platform are shown.

## **2 Overall Design and Development Environment Description of the Platform**

### **2.1 General Design Framework of Internet of Things System and Agricultural Network Information Resource Sharing System**

In order to realize the design of agricultural network information resource sharing system and the optimal scheduling of agricultural network information service resource information, the overall design framework of the platform is analyzed at first. VXI bus technology is used to collect the information resources of agricultural network information service, and the software of agricultural network information resource sharing system is developed and designed under the embedded kernel. The platform uses LabWindows/CVI to open up the code resources. The agricultural network information resource sharing system is mainly divided into agricultural network information service resource retrieval module, agricultural network information resource integration processing module, bus control module, resource information fusion module, program loading and compilation module and human-computer interaction module [8]. The information perception module is constructed to realize the information collection of agricultural network information service resources, the collected agricultural network information service resource information is processed adaptively, and the underlying database is constructed to realize the storage of agricultural network information service resources. In the local memory module, the program loading and compiling software is used to compile and read and write the control instructions of the new media agricultural network information resource sharing system. The embedded

controller PXI-8155 is used to construct the network communication protocol, and the online automatic monitoring and network transmission design of the agricultural network information resource sharing system is carried out under the condition of Internet of things technology [9]. Build ZigBee terminal node, build the Internet of things architecture of agricultural network information resource sharing system. The video equipment is used to monitor the teacher and the indoor environment of the agricultural network information in real time. The user can access the server through the PC machine or mobile phone, and the data fusion and data processing analysis of the collected agricultural network information service platform can be carried out in the central information processing unit. The remote transmission protocol is constructed in the local database to realize the output control and storage of the information sharing system of the new media agricultural network information resources. ZigBee data collection node is designed as the bottom node of the Internet of things, which is uploaded to the remote data center server through GRPS [10], and the sensor node is constructed to realize the original data collection, local information processing and remote data transmission and control of the agricultural network information service. The network structure model of the designed agricultural network information resource sharing system is shown in Fig. 1.

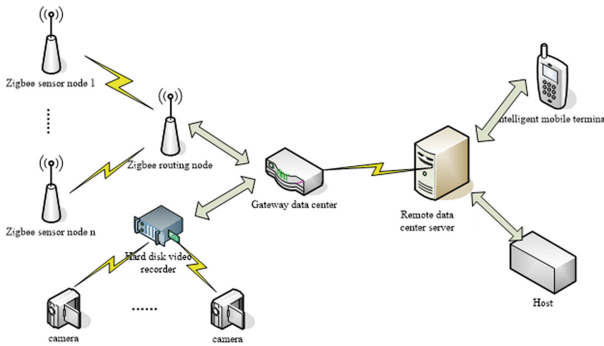

**Fig. 1.** Internet of things architecture of agricultural network information resource sharing system

According to the architecture of Internet of things shown in Fig. 1, the information dispatching network center of agricultural network information service resources is established under the environment of Internet of things technology, and the network design and system development of agricultural network information service platform are carried out by using network networking technologies such as ZigBee and GPRS. The ZigBee sensor node and hard disk video data are uploaded to the network data center and to the intelligent mobile terminal through the remote data center server. The overall structure of agricultural network information resource sharing system designed in this paper is shown in Fig. 2.

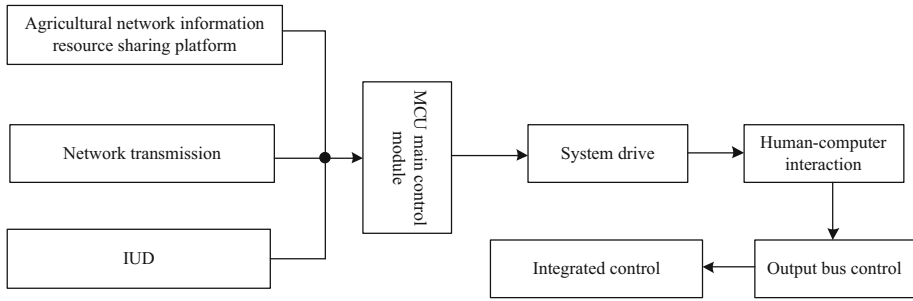
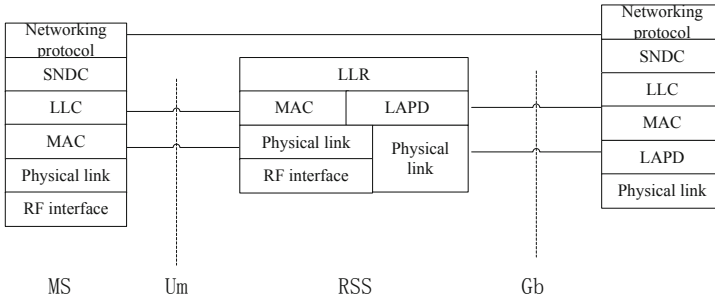

**Fig. 2.** Overall structural framework of the system

According to the overall architecture shown in Fig. 2, the bus control of agricultural network information resource sharing system is automatically monitored by VIX bus. The sensor group used in the platform adopts ZigBee protocol for ad hoc network and wireless data transmission, and makes full use of open source Linux operating platform to design the internal cache control and human-computer interaction of agricultural network information resource sharing system [11].

## 2.2 Function Module Analysis and Development Environment Description of the System

On the basis of the overall framework design of the system, the function modular design of the system is carried out, a MySQL construction agricultural network information service management database is constructed, the network design of the agricultural network information resource sharing system is carried out under the B/S structure system, the agricultural network information resource sharing system is divided into an agricultural network information service resource agricultural network information resource integration processing module [12], a control module, an interface module, a program loading and compiling module, a bus module and the like, the program loading and compiling control of the agricultural network information resource sharing system is carried out by using the Native app local application program and the Web app web page application program, the MySQL is used as a database, and the collected agricultural network information service resource information is analyzed and the resource scheduling processing under the embedded system bus. In this paper, an information management system of agricultural network information is constructed, and an open network system model is adopted, and the network networking design and database design of the agricultural network information resource sharing system are carried out. The overall structure design of the agricultural network information resource sharing system designed in this paper is the B/S architecture design, that is the client/server structure [14]. The control protocol of the agricultural network information resource sharing system is constructed by using the GPRS protocol model shown in Fig. 3.



**Fig. 3.** GPRS protocol model

According to the Internet of Things GPRS protocol model shown in Fig. 3, the GPRS protocol model is divided into a radio frequency interface part, a GPRS air interface layer, a medium access control layer, a program loading and compiling layer, an MCU layer and a physical link layer:

- (1) The radio frequency interface part adopts the Um interface to realize the man-machine interaction design of the physical layer access and the radio frequency interface of the agricultural network information resource sharing system, and the physical link layer realizes the physical access and sensor information acquisition of various AD sampling interfaces. A distributed networking architecture is adopted to construct various logical channels of the air interface of the agricultural network information service system under the internet of things.
- (2) The MAC bit medium access control layer. The MAC layer adopts a bus control design, carries out process management and bus scheduling under the MVB bus control protocol, Such that the channels can be shared by different mobile stations.
- (3) The LLC layer is a logical link control layer, adopts a wireless link protocol of HDLC, and when the running NextTask () enters an infinite loop task, a multi-thread agricultural network information resource sharing system task scheduling method is adopted, and the LLC address and the frame field are designed, and the on-line interface design and program loading and compiling of the agricultural network information service system are completed.
- (4) SNDC is called a subnet-dependent binding layer. SNDC adopts an on-line response channel mode to carry out the bus scheduling and the base database design of the agricultural network information service system, and the main function of the invention is to complete the grouping and packing of the data, and to determine the TCP/IP address and the encryption mode.
- (5) The protocol SIP of the network layer has a distributed multicast function. SIP also provides good quality of service support, and the network layer protocol uses TCP/IP and X.25 protocols that are transparent to traditional GSM network devices such as BSS and NSS.

According to the analysis, the three-tier architecture of agricultural network information resource sharing system is shown in Fig. 4.

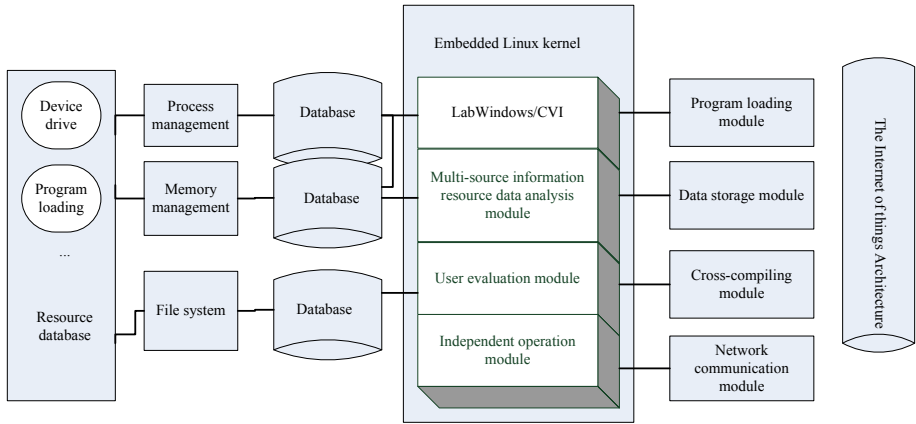

Fig. 4. Three-tier architecture of agricultural network information resource sharing system

### 3 Development and Design of System Software

#### 3.1 Algorithm Design of Agricultural Network Information Service Resource Retrieval

The bottom module of agricultural network information resource sharing system is designed by using B/S architecture protocol and bus server system, and the retrieval design of massive agricultural network information service resources is carried out based on Internet of things technology. In the above, the overall architecture design and functional index analysis of large-scale agricultural network information resource sharing system are carried out, and the fusion algorithm of agricultural network information service resources is designed. To realize the information resource sharing resource scheduling of new media agricultural network, this paper adopts a fuzzy linear fusion model of agricultural network information resource scheduling. Under the constraint of extreme learning, the fuzzy membership function of agricultural network information service resource fusion is constructed as follows:

$$P_F = \sum_{j=k}^N \sum_{u_i=j} \prod_{i=1}^N (P_{fi})^{u_i} (1 - P_{fi})^{1-u_i} \quad (1)$$

$$P_D = \sum_{j=k}^N \sum_{u_i=j} \prod_{i=1}^N (P_{di})^{u_i} (1 - P_{di})^{1-u_i} \quad (2)$$

Wherein,  $P_{fi}$  represents the fusion clustering center of big data distribution of agricultural network information service resources.  $P_{di}$  is the sampling frequency of

agricultural network information service, and the example set of data flow is described as follows:

$$\bar{x} = \frac{1}{N} \sum_{i=1}^N |x_i| \quad (3)$$

In the data fusion center of information management system, the data attribute set of agricultural network information service resources is constructed, and the root mean square error of data classification is obtained as follows:

$$\sigma^2 = \frac{1}{N} \sum_{i=1}^N |x_i - \bar{x}|^2 \quad (4)$$

In the attribute set distribution space of agricultural network information service resource data, linear regression analysis and correlation analysis are used to obtain the mining results of segmented fusion of agricultural network information service resources:

$$x'_i = \frac{x_i}{\|x_i\|} = \left( \frac{x_{i1}}{\|x_i\|}, \frac{x_{i2}}{\|x_i\|}, \dots, \frac{x_{iN}}{\|x_i\|} \right) \quad (5)$$

Wherein, the dynamic replica value  $x_N$ , of agricultural network information service resource data is used in the data clustering space, and the fuzzy C-means and support vector machine algorithm are used to cluster the agricultural network information service resource, and the output characteristic quantity after data clustering is obtained as:

$$X_p(u) = s_c(t) e^{j2\pi f_0 t} = \frac{1}{\sqrt{T}} \text{rect}\left(\frac{t}{T}\right) e^{j2\pi(f_0 t + Kt^2)/2} \quad (6)$$

Wherein,  $s_c(t)$  represents the scalar time series in the data set of agricultural network information resource sharing system,  $e^{j2\pi f_0 t}$  represents the feature matching set of information fusion, and  $f_0$  represents the reference frequency component, thus realizing the information fusion and integrated scheduling of agricultural network information service resources [15].

### 3.2 Modularization Design of Software Function

The above designed agricultural network information resource scheduling algorithm realizes the resource information fusion of the algorithm through the resource information fusion module. The SQLServer2012 database is designed in embedded Linux to store the agricultural network information service resource information, and the agricultural network information service resource collection and data loading subroutine is established by using TCP/IP (Transmission Control Protocol/Internet Protocol) transmission control protocol, and the PWM related buffer is set up. The data source is

written into the DataSet of agricultural network information resource sharing system, and the data source is bound according to the data in DataSet. The request\_irq () function is called to apply for character device driver, and the program loading and compiling and multi-mode control of agricultural network information service resources are realized in cloud computing and Internet of things environment. The trigger bus of agricultural network information resource sharing system is composed of 8 TTL trigger lines and 6 ECL trigger lines, and the minimum communication is carried out by VXI special string protocol. The external controller of agricultural network information resource sharing system is constructed. in the SCSI bus driver design of agricultural network information resource sharing system, the ability of real-time data recording is improved by connecting external PC and VXI bus through MXI-2 bus. The resource information fusion module is the key module to realize the core program processing of the agricultural network information service resource management system. The resource information fusion module adopts the embedded Web service design method, which can realize the collection and adaptive processing of the agricultural network information service resources, construct the ROMFS file system in the physical storage medium, and use ADO. NET to complete the query of the large-scale agricultural network information resource sharing system in the Web programming design. Update and database management, the physical layer and MAC layer of agricultural network information service system adopt IEEE802.15.4 protocol standard. The working rate of distribution node in the middle layer of network is between 20–250kbps. According to the data output from GPRS network, the data bit is sent and received to the RF byte component in the upper layer, which makes the GPRS system meet the required memory, energy consumption and speed. Under the B/S architecture protocol and the bus server system, the software development and design of the independent agricultural network information resource sharing system are carried out. The underlying module of agricultural network information resource sharing system is designed by embedded Boot loader driver module, the process management program is called, and the information collection is carried out through VME bus or local bus transmission technology, thus the software system of agricultural network information resource sharing system is constructed.

## 4 System Test and Performance Analysis

In order to test the application performance of the agricultural network information resource sharing system designed in this paper, carry on the software debugging and simulation experiment, the agricultural network information resource sharing system provides the user with a simple and unified system calling interface, realizes the information processing and the system integration design, uses the embedded Linux as the kernel to carry on the agricultural network information resource sharing system software development and design. Under X86 architecture, GNU development tool set is used to test the software of agricultural network information resource sharing system, ast\_sip\_realtime class is used to read data directly from database, Sip protocol stack is used to establish session protocol of agricultural network information service system, sip\_call interface is called to create INVITE message outgoing, and channel\_bridge

function is called to connect two channels, thus the test environment of agricultural network information resource sharing system is constructed. The data block size of data sampling for agricultural network information service resources is 200 m. The task set of agricultural network information service resources scheduling is divided into 10 queue. The parameters of agricultural network information service operation are set in Table 1.

**Table 1.** Job parameter settings

Number of jobs	Number of tasks	Proportion of agricultural network information service operations
20	1–5	55.7%
13	5–20	25%
10	21–40	10%
8	41–50	6%
6	51–100	2%

According to the above software test environment and parameter setting, the performance of the agricultural network information resource sharing system is tested, and the big data sampling sequence of the information transmission of the agricultural network information service system is obtained as shown in Fig. 5.

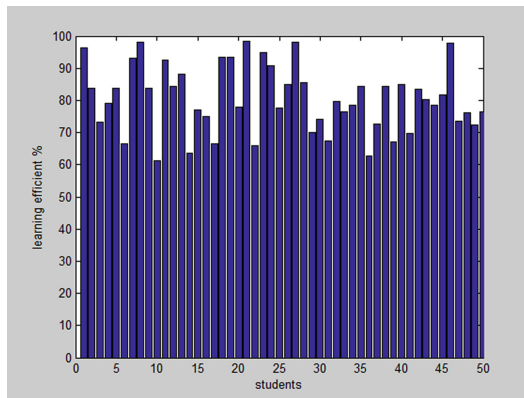

**Fig. 5.** Big data sampling sequence of information transmission in agricultural network information service system

The agricultural network information service system information shown in Fig. 5 is used as the sample to send the big data sampling sequence, and the network transmission performance of the agricultural network information resource sharing system is tested. Figure 6 shows the time cost of scheduling the agricultural network information service resources under different scale data sets.

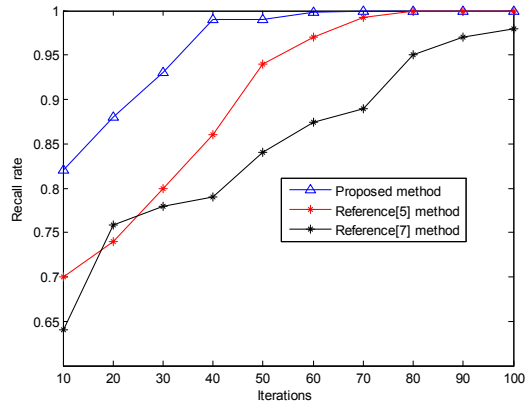

**Fig. 6.** Comparison of resource recall performance

The analysis of Fig. 6 shows that the recall performance of the new media agricultural network information resource scheduling designed by this method is better, which is 24.5% and 19.8% higher than that of the traditional method. In order to further verify the effectiveness of this system, the execution time cost of this system, document [5] system and document [7] system are compared, and the comparison results are shown in Fig. 7.

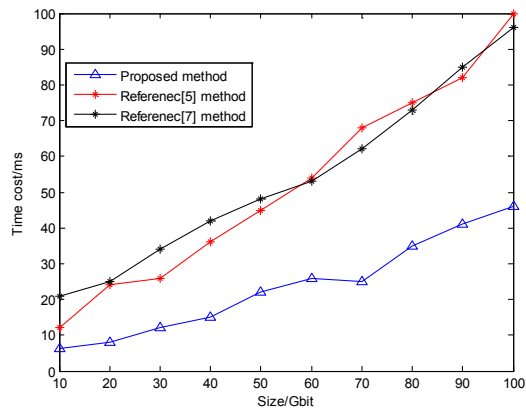

**Fig. 7.** Comparison of execution time overhead

The analysis of Fig. 7 shows that the execution time cost increases with the increase of the scale of agricultural network information resources sharing resource data. The overall time cost of this method is obviously lower than that of the traditional method, and the execution cost is shortened by 46.7% and 40.4%.

## 5 Conclusions

In this paper, the agricultural network information service system is constructed to integrate the agricultural network information service resource information and improve the sharing level of the agricultural network information resource information, and this paper proposes to construct the agricultural network information resource sharing system based on the Internet of things. The VXI bus technology is used to collect the information resources of agricultural network information service, and the software development and design of agricultural network information resource sharing system are carried out under the embedded kernel, and the network design and system development of agricultural network information service system are carried out by using ZigBee and GPRS and other network networking technologies. B/S framework protocol and bus server system are used to design the underlying module of agricultural network information resource sharing system, and the retrieval design of massive agricultural network information service resources based on Internet of things technology is carried out to realize the core algorithm design and software development of the system. It is found that the agricultural network information resource sharing system under the Internet of things technology designed in this paper has good resource recall performance, low execution time cost and good overall stability. However, this system does not consider the cost when sharing the agricultural network information resources. In the next study, we will take the cost as the research index to further study the agricultural network information resources sharing.

## References

1. Huang, H., Xiaotian, G.E., Chen, X.: Density clustering method based on complex learning classification system. *J. Comput. Appl.* **37**(11), 3207–3211 (2017)
2. Ji, Y., Li, Y., Shi, C.: Aspect rating prediction based on heterogeneous network and topic model. *J. Comput. Appl.* **37**(11), 3201–3206 (2017)
3. Xiao, K., Du, Z., Yang, L.: An embedded wireless sensor system for multi-service agricultural information acquisition. *Sens. Lett.* **15**(11), 907–914 (2017)
4. Blanco, A.C., Tamondong, A., Perez, A.M., et al.: Nationwide natural resource inventory of the Philippines using LiDAR: strategies, progress, and challenges. *ISPRS J. Photogram. Remote Sens.* **XL I**(B6), 105–109 (2018)
5. Slimeni, F., Scheers, B., Nir, V.L., et al.: Learning multi-channel power allocation against smart jammer in cognitive radio networks. In: *Proceedings of the 2016 International Conference on Military Communications and Information Systems*, Piscataway, NJ, pp. 1–7. IEEE (2016)
6. Eski, İ., Kuş, Z.A.: Control of unmanned agricultural vehicles using neural network-based control system. *Neural Comput. Appl.* **31**, 583–595 (2019). <https://doi.org/10.1007/s00521-017-3026-4>
7. Han, B., Li, Y.: Optimization method for reducing network loss of dc distribution system with distributed resource. *Photon. Netw. Commun.* **37**(2), 233–242 (2018). <https://doi.org/10.1007/s11107-018-0805-5>

8. Mougin, C., et al.: BRC4Env, a network of Biological Resource Centres for research in environmental and agricultural sciences. *Environ. Sci. Pollut. Res.* **25**(34), 33849–33857 (2018). <https://doi.org/10.1007/s11356-018-1973-7>
9. Shi, J., Feng, Z., Liu, J.: Design and experiment of high precision forest resource investigation system based on UAV remote sensing images. *Nongye Gongcheng Xuebao/Trans. Chin. Soc. Agric. Eng.* **33**(11), 82–90 (2017)
10. Xing, X., Shang, Y., Zhao, R., Li, Z.: Pheromone updating strategy of ant colony algorithm for multi-objective test case prioritization. *J. Comput. Appl.* **36**(9), 2497–2502 (2016)
11. Zhang, H., Shao, Z., Zhang, Z., et al.: Regulation system of CO<sub>2</sub> in facilities based on wireless sensor network. *Nongye Jixie Xuebao/Trans. Chin. Soc. Agric. Mach.* **48**(3), 325–331, 360 (2017)
12. Parsley, S.: Accessing good health information and resources. *Commun. Eye Health* **30**(97), 15–17 (2017)
13. Zhang, X.-B., Li, M., Wang, H., et al.: Location information acquisition and sharing application design in national census of Chinese medicine resources. *Zhongguo Zhong yao za zhi = Zhongguo zhongyao zazhi = China J. Chin. Materia Medica*, **42**(22), 4271–4276 (2017)
14. Wang, L.: Optimization process of compiling and researching archives in universities under the background of information sharing. *Int. Technol. Manag.* **6**, 36–38 (2017)
15. Wang, Y., Li, C., Cui, Y., et al.: Construction of PaaS platform based on Docker. *Comput. Syst. Appl.* **5**(3), 72–77 (2016)