





Prediction of Risks Assessment in the Workplace Using Online Monitoring

Lucia Knapčíková¹ (✉) , Annamária Behúnová² , Jozef Husár¹ ,
Rebeka Tauberová¹, and Matúš Martiček¹

¹ Faculty of Manufacturing Technologies With a Seat in Prešov, Department of Industrial Engineering and Informatics, The Technical University of Košice, Bayerova 1, 080 01 Prešov, Slovak Republic

{lucia.knappcikova, jozef.husar, rebeka.tauberova}@tuke.sk,
matus.marticek@student.tuke.sk

² Faculty of Mining, Ecology, Process Control and Geotechnologies, Institute of Earth Resources, Technical University of Košice, Košice, Slovak Republic
annamaria.behunova@tuke.sk

Abstract. The digitization of technological processes in enterprises is rapidly changing the world of work and requires new and up-to-date solutions in occupational health and safety (OSH). The European Agency for Safety and Health at Work (EU-OSHA) provide information to policymakers, researchers and workers about the possible effects of digitization on OSH, so that they can take timely and effective measures to ensure the safety and protection of workers. Occupational health and safety are often poorly managed in micro and small enterprises, and employees are exposed to a greater risk of workplace injuries and occupational diseases. The paper deals with online monitoring of risk assessment in the injection moulding workplace and is key to creating healthy workplaces. However, conducting a risk assessment can be quite challenging, especially for micro and small businesses that may lack the resources or expertise to do it effectively.

Keywords: Monitoring · Communication · Circular Economy · Sustainability

1 Introduction

Safety and health protection at work can be defined as the state of the workplace, which ensures that in compliance with rules such as technological procedures, safety regulations, etc., a situation will not arise that would endanger workers' health [1]. To create safe work, in which the protection of the worker's health is to be observed, it is required to develop and implement a system of measures such as legislative, economic, social, organizational, technical, health and educational. [2] Despite the implementation of all available measures to increase safety, health protection and conscientious compliance with the organization's occupational safety and health policy (OSH) by employees, it does not exclude the occurrence of an undesirable situation that leads to occupational accidents [1, 2]. If such an undesirable situation occurs, it is necessary to proceed according to the applicable legislation [3].

Hazard identification is the process of identifying whether a given hazard exists. This process also determines what the hazard can cause. The identified danger is then assessed, and one of the options is selected [3]:

- 1) interruption of the process due to a danger that is incompatible with the damage they can cause,
- 2) immediate adoption of corrective measures that eliminate or reduce threats arising from the hazard,
- 3) termination of the analysis due to negligible dangers,
- 4) continuation of risk identification.

The term threat means any activity that leads to the emergence of a dangerous situation. It represents a danger that causes negative phenomena such as injury or damage in a specific space and time in the machine-person-environment system [4].

The hazard identification stage is followed by the threat title and, at the same time, its analysis. This process represents the determination of threats that result from hazards and lead to an injury, damage or another negative phenomenon. Therefore, it is important to determine the course and method of potential negative risk in the machine-man-environment system. In this section, it is important to realize that one danger can cause more threats [2, 3].

Control measures for the identified threat [1, 2]:

- 1) Elimination - removal: introducing automated devices that reduce the manual work performed and eliminated threats.
- 2) Substitution - alternative: this measure is used if it is impossible to eliminate the threat. In such a case, possible options are sought to replace the materials, machines and equipment that are safer and eliminate the risk of injury or occupational disease.
- 3) Technical controls: they consist of the design of the workplace and the activities performed by the worker. An example can be technical noise control and the subsequent proposal of corrective measures such as anti-noise walls, covers and isolating employees from excessive noise.
- 4) Administrative regulation: represents measures, the content of which is the reworking of work procedures, introducing new strategies and determining the use of PPE.

1.1 The Risk Identification

It includes the process of identification, knowledge and assessment of existing, possible and emerging risks, which carry with them the probability of the occurrence of a negative phenomenon [1, 4].

The identification process must take risks into account, regardless of whether the given source of risk is under the organisation's control but also if the individual sources of risks and their causes are not obvious [5]. It must contain an assessment of the induced effects with consequences. It is important to consider the wide range of values, even if the individual sources of risks and their causes are not obvious [4]. It is also necessary to take into account what can happen and, at the same time, consider possible undesirable reasons and circumstances that indicate the consequences that could occur. All important causes and effects should be considered [5, 6] (Fig. 1).

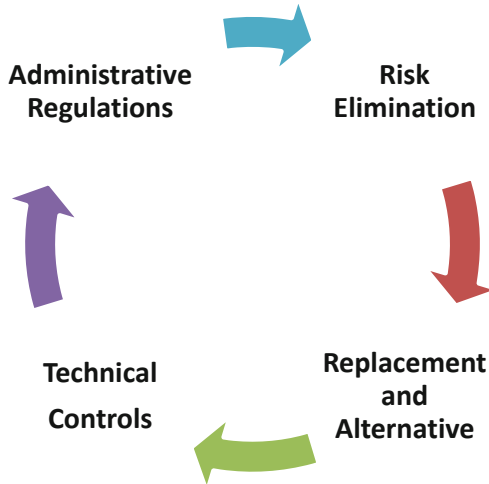

Fig. 1. The process of Online Monitoring [Authors own processing]

The process of identifying and assessing adverse events that lead to the creation and realization of risks, analysis of mechanisms leading to these situations, and assessment of the scope, size and probability of occurrence of any event that could harm the company “[6].

It consists of the following steps [4, 7]:

- determination of the assessed system,
- hazard identification,
- threat identification,
- determination of risks.

Monitoring is a tool to track almost everything - from the location of objects to the utilization of machines and the charging cycle of the battery of the transporting forklift - where such maintenance saves energy - to the list of people who are still on their way to work. Risk analysis is important in determining whether risks need to be addressed in a given chosen system and what method needs to be used to assess risk [6]. It provides information about individual sources of risk and also about positive or negative consequences and probabilities that may occur [7]. It has the task of identifying the factors that influence the values and, at the same time, their possibility. The risk is often expressed from a combination of consequences and probabilities [8]. In terms of the purpose of the analysis, available sources, information and data, the study can be qualitative, semi-quantitative or quantitative [7, 8].

2 Work Methodology

Digital technologies have brought new forms of employee management. Unlike previous forms of management that relied heavily on human supervision, AI workforce management relies on new management systems and tools that gather real-time data

on worker behaviour from various sources [6]. The goal is to inform management and support automated or semi-automated decisions based on algorithms or more advanced forms of artificial intelligence [5]. Research in this area identifies and discusses the possibilities that these new systems provide for management based on artificial intelligence because if they are created and implemented transparently, and employees are informed and consulted, they can support decisions to improve health and safety in the workplace [6, 7]. In addition, the research maps and discusses challenges in the legal, regulatory, and ethical fields, as well as issues related to privacy and risks and concerns in the area of health and safety, especially about psychosocial risk factors that these new forms of monitoring and management of workers also cause [8, 9] (Fig. 2)

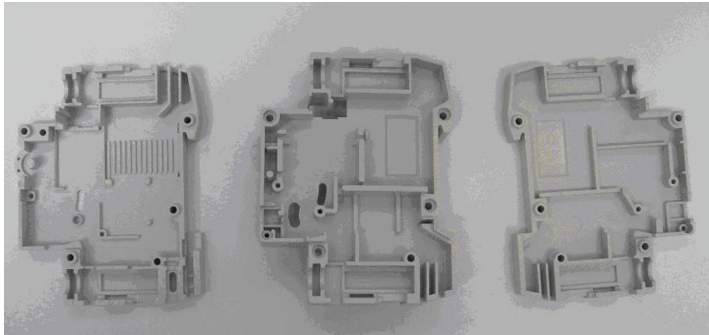

Fig. 2. The monitored samples of the final product [10].

Online monitoring and identification of risks at the injection moulding workplace was implemented in a company that focuses mainly on producing components for the electrical industry [10, 11]. The operation also uses other equipment designed for handling forms and moving material, such as a forklift and a gantry crane with a load capacity of up to 5000 kg [11]. A forklift is used for other injection moulding machines to change the mould. A very important task is also the drying of the material called granulate. The reservoirs of other injection moulding machines are filled manually, but before that, the granulate is dried in dryers that do not perform the function of automatic transfer of granulate to the reservoir [10]. It mainly concerns the production of mouldings of single and multi-pole circuit breakers, protectors, cam switches, and household electrical installation materials such as single and double 230V sockets, 400V sockets, switchboards, etc. [12] (Fig. 3).

3 Results and Discussion

The risk situations in the operation of injection moulding machines are the fall of the load and the slip - the fall of a person [10, 13]. They enter mainly using a forklift truck and filling dryers and hoppers of injection moulding machines [14]. These situations can seriously damage the health of workers (Fig. 4).

The following situation with a high level of risk is a slip - a person's fall, which most often occurs when filling the hoppers of dryers and injection moulding machines [15,



Fig. 3. The monitored products [10].

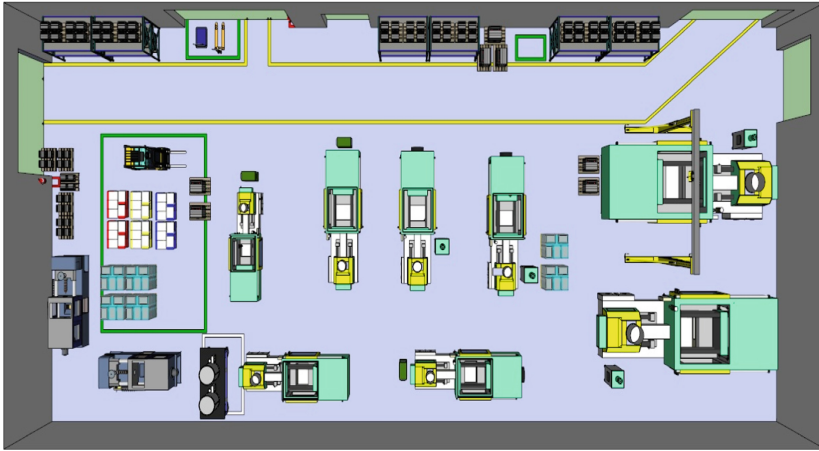

Fig. 4. Model of the current state of operation of injection moulding machines [10].

16]. To eliminate this risk, a model of preparation for filling these reservoirs with an active sensor using a bridge crane was created [17, 18] (Fig. 5).

Legend to Fig. 6

1. Preparation container
2. Eyelets for fastening the rope
3. A spring connected to a fixed part and a movable foot
4. The area of material (granules) coming out of the hopper
5. A foot of the proposed preparation

Legend to Fig. 7

1. Preparation for filling reservoirs
2. Middle piece for the upper part of the magazine
3. Reservoir

The mentioned preparation represents a simple mechanism. Its principle consists of filling the preparation with coarse material from a bag or dryer and subsequent transfer using a bridge crane above the level of the injection moulding tank [19, 20] (Fig. 8).

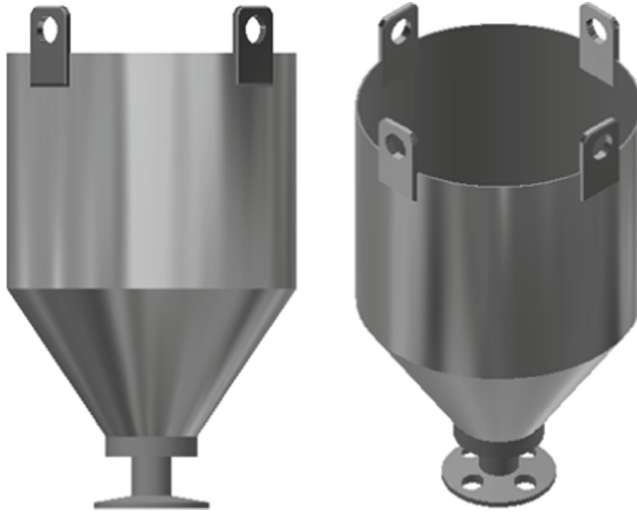

Fig. 5. Model of preparation for filling reservoirs [10].

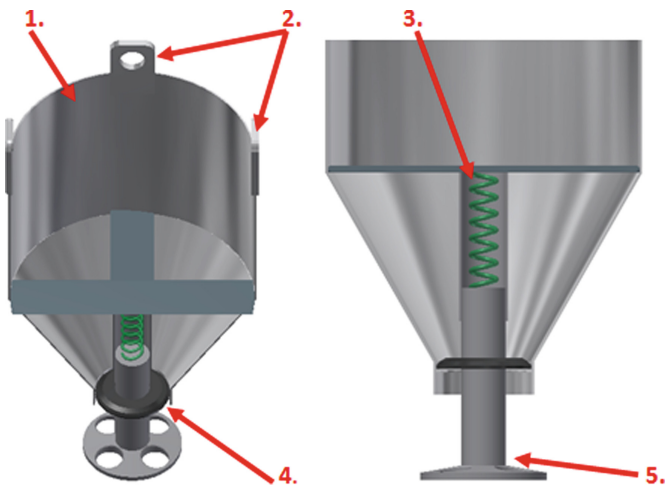

Fig. 6. The main parts of the preparation [10].

Legend to Fig. 9

1. The preparation is closed
2. The preparation is open

When lowering, the foot of the preparation rests on the intermediate piece of the upper part of the container, and the weight of the preparation and the filled granulate pushes the foot into the inner part, which partially opens the closing position [20, 21]. After opening, the granulate is poured directly into the hopper of the injection moulding machine. When raised again, the spring pushes the foot outwards, closing the closing

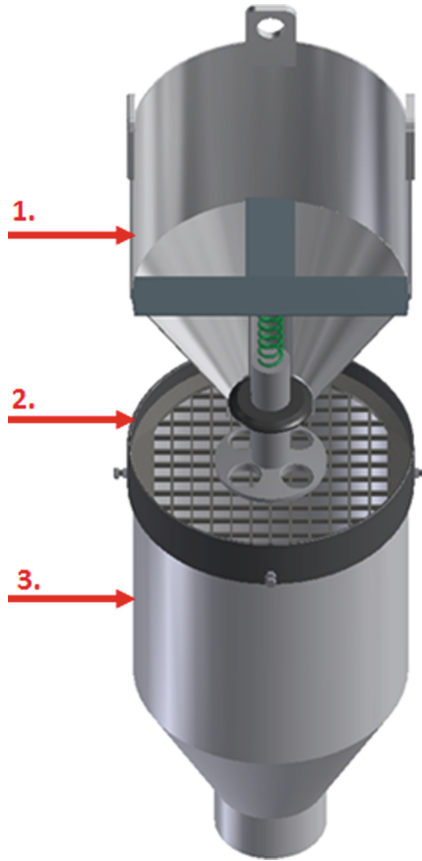

Fig. 7. Basic component mode [10].

part. Part of the data collection process is to document the state of production at individual workplaces as well as service processes [21]. Both employers and logistics contribute to this. As part of logistics, we take care of resources, where we deal with efficiency, health and safety, technology monitoring, material flow, and maintenance. The goods must be at the designated place and the product produced on time (Fig. 10).

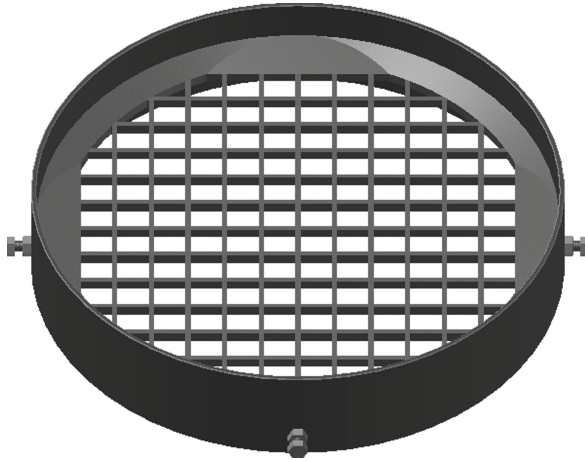

Fig. 8. The proposed spacer [10].

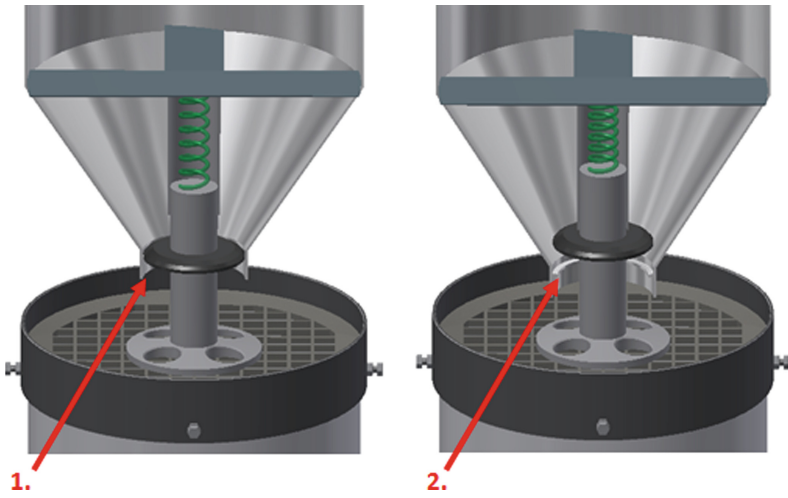

Fig. 9. The principle of the preparation [10].

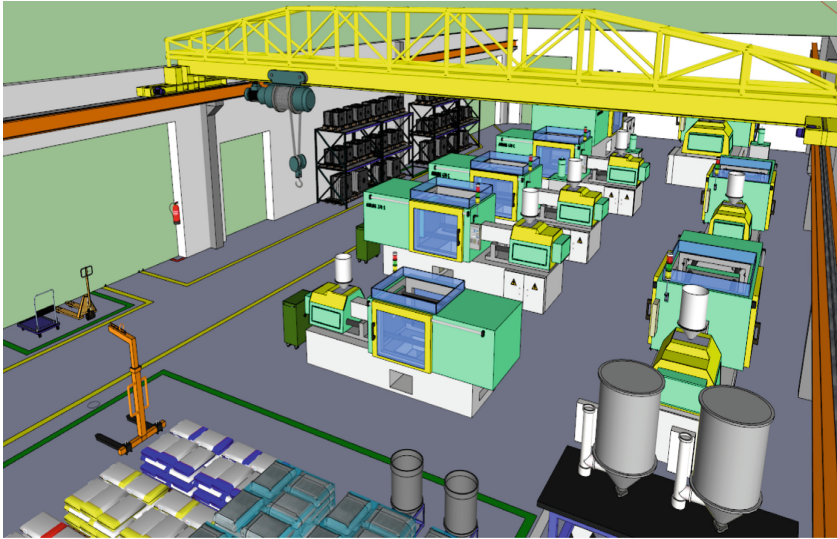

Fig. 10. The workstation view

4 Conclusion

The research aimed to predict, monitor and subsequently minimize risks when working in the injection moulding department based on theoretical principles from the safety and health protection field. Part of the main activities of every company should be creating safe work at the workplace, which should ensure the protection of the employees' health. An important condition is the identification of dangers, and threats, the definition of risk levels and subsequent solutions for risk elimination. To carry out the risk identification, it was important to characterize the production and the detailed activities of individual workers where there are potential dangers and threats. Operational safety is also one of the company's priorities. Increasing production, movement of equipment, employees, visitors brings various dangerous situations. Digital technologies also increase security of whole company. They know how to guard the authorized use of technology and the authorization of the operator; they prevent collision situations between vehicles and pedestrians. This will prevent damage, injuries and unnecessary costs associated with accidents and maintenance.

Acknowledgements. This work was supported by the projects VEGA 1/0268/22, KEGA 038TUKE-4/2022 granted by the Ministry of Education, Science, Research and Sport of the Slovak Republic.

References

1. Periša, M., Cvitić, I., Peraković, D., Husnjak, S.: Beacon technology for real-time informing the traffic network users about the environment. *Transport* **34**, 373–382 (2019). <https://doi.org/10.3846/transport.2019.10402>
2. Nagyova, A., Pacaiova, H., Markulik, S., et al.: Design of a Model for Risk Reduction in Project Management in Small and Medium-Sized Enterprises. *Symetry-Basel*, vol. 13 (5) (2021). <https://doi.org/10.3390/sym13050763>
3. Periša, M., Kuljanić, T.M., Cvitić, I., Kolarovszki, P.: Conceptual model for informing user with innovative smart wearable device in industry 4.0. *Wireless Netw.* **27**(3), 1615–1626 (2019). <https://doi.org/10.1007/s11276-019-02057-9>
4. Straka, M., Khouri, S., et al.: Utilization of computer simulation for waste separation design as a logistics system. *Int. J. Simul. Modelling* **17**(4), 83–596 (2018). [https://doi.org/10.2507/IJSIMM17\(4\)444](https://doi.org/10.2507/IJSIMM17(4)444)
5. Gou, Z., Yamaguchi, S., et al.: Analysis of various security issues and challenges in cloud computing environment: a survey. In: *Identity Theft: Breakthroughs in Research and Practice*, pp. 221–247. IGI global (2017)
6. Prandi, C., Nunes, N., Ribeiro, M., Nisi, V.: Enhancing sustainable mobility awareness by exploiting multi-sourced data: the case study of the Madeira Islands. *Sustainable Internet and ICT for Sustainability (SustainIT)*, Funchal, pp. 1–5 (2017)
7. Hugos, M.H., Hultzky, D.: *Business in the cloud: what every business needs to know about cloud computing*. John Wiley & Sons, p. 139 (2010)
8. Lee, C.K.M., Zhang, S.Z., Ng, K.K.H.: Development of an industrial Internet of things suite for smart factory towards re-industrialization. *Adv. Manuf.* **5**(4), 335–343 (2017). <https://doi.org/10.1007/s40436-017-0197-2>
9. Globa, L., Kurdecha, V., Ishchenko, I., Zakharchuk, A., Kunieva, N.: The intellectual IoT-system for monitoring the base station quality of service. In: *2018 IEEE International Black Sea Conference on Communications and Networking (BlackSeaCom)*, Batumi, pp. 1–5 (2018). <https://doi.org/10.1109/BlackSeaCom.2018.8433715>
10. Foriš, J.: Identification of risks at the workplace of injection pressers in the selected company. Technical University of Košice, Thesis (2017)
11. Catini, A., et al.: Development of a sensor node for remote monitoring of plants. *Sensors* **19**, 4865 (2019)
12. Giordano, M.R., et al.: From low-cost sensors to high-quality data: a summary of challenges and best practices for effectively calibrating low-cost particulate matter mass sensors. *J. Aerosol Sci.* **158**, 105833 (2021). <https://doi.org/10.1016/j.jaerosci.2021.105833>
13. Fözö, L., et al.: Simulation aspects of adaptive control design for small turbojet engines, in *Intelligent Engineering Systems*, (IEEE Industrial Electronics Society, Budapest (Mad'arsko), 2019), pp. 101–106. ISBN 978-1-7281-1212-
14. Chen, X.Y., Jin, Z.G.: Research on key technology and applications for internet of things. *Phys. Procedia* **33**, 561–566 (2012)
15. Vegsoova, O., Khouri, S., Straka, M., Rosova, A., Kacmary, P., Betus, M.: Using technical means and logistics principle applications to solve ecological water course accidents. *Pol. J. Environ. Stud.* **28**(5), 3875–3883 (2019)
16. Lamont, G.B., Slear, J.N., Melendez, K.: UAV swarm mission planning and routing using multi-objective evolutionary algorithms. Presented at the 2007 IEEE Symposium on Computational Intelligence in Multi-Criteria Decision-Making (2007)
17. de Melo, V.V., Banzhaf, W.: Drone Squadron Optimization: a novel self-adaptive algorithm for global numerical optimization. *Neural Comput. Appl.* **30**(10), 3117–3144 (2017). <https://doi.org/10.1007/s00521-017-2881-3>

18. Drozd, W., Leśniak, A.: Ecological wall systems as an element of sustainable development cost issues. *Sustainability* **10**(7), 2234 (2018)
19. Marto, A., Goncalves, A.: Mobile AR: User Evaluation in a Cultural Heritage Context. *Applied Sciences-Basel*, vol. 9 (24), 5454 (2019)
20. Mesároš, P., Mandičák, T.: Information systems for material flow management in construction processes. In: *IOP Conferences Series: Materials Science and Engineering*, pp. 1–5 (2015)
21. Trebuňa, P., et al.: 3D scanning as a modern technology for creating 3D models. *Acta Technológica* **6**(1), 21–24 (2020)