



A Percolation-Based DTNs Routing Using Fountain Coding

Ruxin Zhi^{1,2(✉)}, Bilei Zhou³, and Zhigang Tian⁴

¹ Key Laboratory of Information and Communication Systems, Ministry of Information Industry, Beijing Information Science and Technology University, Beijing 100101, China
zhiruxin@bistu.edu.cn

² Key Laboratory of Modern Measurement and Control Technology, Ministry of Education, Beijing Information Science and Technology University, Beijing 10010, China

³ Shanghai Institute of Satellite Engineering, Shanghai 200240, China

⁴ Tsinghua University, Beijing 100080, China
zgtian@tsinghua.edu.cn

Abstract. In Delay/Disruption Tolerant Networks (DTNs), an upper bound of the propagation delay and a persistent bi-direction link is not required. Thus, DTNs is considered as an effective extension to the existing network infrastructures and targeted to solve the problems that it is unable to communicate under extreme conditions. However, the long delay and frequent interruption of links in DTNs lead to routing strategy, a hot issue in DTNs research. From the perspective of efficient data transmission and information security, PFC-DRP, a DTNs routing protocol based on percolation and fountain coding is proposed. Since data theft and interception on a single path does not pose a serious threat to the leakage of complete data, the security of data transmission is guaranteed. At the same time, the proposed protocol effectively improves routing robustness. According to the simulation results, compared with other protocols, the proposed protocol achieves higher message delivery performance and reduces the overhead of delivery.

Keywords: Delay/Disruption Tolerant Networks (DTNs) · Routing · Percolation · Fountain Code

1 Introduction

Compared with traditional mobile wireless networks, the routing policy in DTNs faces the challenges of lack of global topology information, limited energy resources of nodes, limited storage space, and prominent security risks [1].

In DTNs, multipath is able to compensate for network performance defects due to long delays and intermittent connections. Multipath routing is dedicated to discovering more than one end-to-end transmission path, which has been studied in the Internet, MANETs, and WSNs [2, 3]. In wireless networks, such as MANETs, the discovery and maintenance of multi-hop paths requires more overhead, but also brings

many advantages, such as balanced link load, increased fault tolerance, increased bandwidth, and reduced end-to-end delay. In addition, in traditional Internets and MANETs, the transport layer-related security mechanisms are based on end-to-end connection acknowledgments.

In DTNs, the mechanism for discovering multiple routes at the same time in MANETs requires high network overhead, which is difficult to implement efficiently. Therefore, in order to balance network load and improve transmission efficiency and security, a routing protocol combining percolation transmission and coding techniques is presented [4]. Further, for the purpose of reducing the delivery cost, this paper converts the end-to-end mechanism into a single-hop acknowledgment mechanism. The rateless digital fountain code is used, which not only has a small coding overhead, but also effectively increases the channel capacity. According to the simulation comparison results, the proposed protocol is an efficient routing protocol.

The rest of this paper is organized as follows. Section 2 introduces the work related to multipath routing, fountain code and percolation. Section 3 presents a notion of the utility value of PFC-DRP and the routing mechanism. Section 4 constructs and simulates the model of the proposed protocol, and compares and analyzes the simulation results. Section 5 provides a brief summary of the research in this paper.

2 Routing in DTNs

The coding technique in DTNs routing compensates for network performance degradation caused by link failure and reduces the overall transmission overhead of the network [5]. There are two types of conventional codes, erasure code and network coding. The erasure code encodes the message at the source node, and increases the reliability by redundancy. The network coding allows the intermediate node to encode the message and encode different messages together. That improves the robustness of the network transmission and reduces the overhead ratio.

The digital fountain code is a type of erasure code. The source node performs fountain coding on the generated message, and encodes the k original packets into any number of encoded packets. The source node continuously transmits the data packets, and the receiving node successfully decodes through any $k(1 + \epsilon)$ coded packets (ϵ is the decoding efficiency), recovering information of all k original packets. The source node continuously generates coded packets, like a fountain erupting water droplets, so it is called “fountain code.” The source node stops transmitting the encoded packet after receiving the ACK message from the destination node, and then starts a new encoding and sending process. The digital fountain code not only has a low overhead and low complexity of coding and decoding, but also effectively increases the channel capacity and increases the robustness of the network. Even if several code blocks on a certain path cannot be transmitted because of link interruption, the decoding of the destination node will not be seriously impaired. As long as the destination node receives enough code blocks, it will decode correctly. In addition, the transmission of different coded packets on the multipath also ensures the security of data transmission. The interception and cracking of any single path data cannot reproduce the complete raw data [7].

3 The PFC-DRP Protocol

This paper proposes a DTNs Routing Protocol based on Percolation and Fountain Coding (PFC-DRP). The protocol combines the technology of multi-path routing penetration transmission and fountain coding, and is committed to achieving high security and balanced network load data transmission.

In this section, we first presents the relevant notions of percolation, then introduces the maintenance of local data and the computation of the utility value, and finally educes the routing mechanism and process of the proposed protocol.

3.1 Percolation

According to the small-world network phenomenon, any two people in the world can be connected by a limited number of hops (5 or 6). When there are enough nodes in the network, each node randomly associates with other nodes to form a small-world model. In such a network, data sent by any one node is able to be forwarded to the destination node with a high probability through the transit of several nodes. In order to achieve efficient forwarding, the choice of intermediate nodes is very critical. Certain social relationships between nodes can be used as a basis for selection.

For the PFC-DRP protocol, the following definitions are proposed:

Definition 1: In the network layer of DTNs, after fountain encoding, the source data packets are sent in parallel through different nodes or paths until they reach the destination node. This process is defined as percolation.

Definition 2: The end-to-end path through which the packet passes from the source node to the destination node is defined as the percolation path.

Definition 3: A fountain-encoded packet transmitted on the percolation path is defined as a percolation packet.

This paper proposes a data transmission technology based on percolation. When any node in the network sends data to a node, the data is segmented and handed over to one or more neighbour nodes that are most likely to transfer the data to the destination node. The same principle is applied to the intermediate node. The amount of data transmitted on the selected plurality of paths is different, related to the forwarding capability of the next hop node.

Since the intermittent connection state between nodes in DTNs cannot guarantee the existence of multipath every moment, the percolation transmission is actually a “quasi” concurrent multipath transmission process. Moreover, due to the sparseness of nodes in DTNs, the number of neighbor nodes cannot be ensured. Therefore, there may be multiple links or multiple node data aggregated to the same node and the continuous occurrence of single-path transmission in actual percolation transmission. Unlike traditional MANETs, which goes from the beginning to the end, more in the DTNs is to judge each step. Hence, multipath is selected as much as possible in each step to achieve multipath distributed transmission of the entire path.

In DTNs, the percolation path is connected to the destination node with a specific probability. The percolation packets of the partial percolation path unlikely to reach the destination are discarded in the network. Figure 1 shows a complete transmission process without the loss of percolation packets. The benefit of fountain coding is that no matter

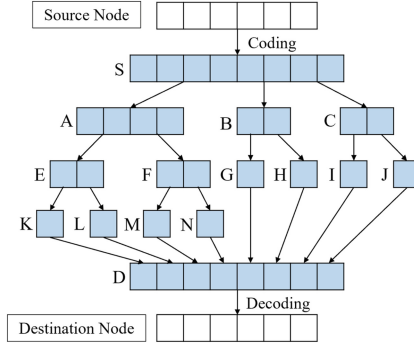

Fig. 1. Percolation Packet Transmission

which path a small number of packets are lost, it does not have a decisive influence on the integrity of the final reception, thus optimizing the efficiency of the transmission. Table 1 summarizes the variables used in our model and their definitions.

Table 1. Variables and Definitions of PFC-DRP

Variable Name	Description
N	set of all the nodes in the network
NB	set of neighbors nodes
NH	set of next hop nodes
U_S^D	unity value of node S for node D
ε	coding rate
k	number of original messages
q	loss rate of packets
M	number of messages generated by source node
K	minimum number of messages that can be decoded correctly in destination node
X	number of messages received by destination node
$encntUtil(v_i, v_j)$	utility value of node v_i and node v_j
$numEncnt(v_i, v_j)$	number of encounter time between node v_i and node v_j
$tsLastEncnt(v_i, v_j)$	last time when node v_i and node v_j meet
$tsNow$	simulation time
γ	decay factor

3.2 The Utility Value

Local Maintenance Data

In the PFC-DRP protocol, the data maintained by each node includes a node encounter information table and a neighbor node encounter information table for route calculation.

The entry of the node encounter information table includes the node address, the number of encounters, the last encounter time, and the most recent update time of the entry. The content of the node encounter information table is periodically sent to the neighbor node along with the broadcast message. The entry of neighbor node encounter information table includes the node address and all of its encounter information entries. The neighbor node encounter information table is not shared with neighbor nodes.

Computation of the Utility Value

In the social network analysis, the attributes that measure the tie strength of the connection between individuals mainly include frequency, intimacy, recency, regularity, and social homogeneity. Applied to DTNs, the frequency of encounters between the pairs of nodes and the number of encounters reflect the closeness of relationship and the possibility of future encounters, so it is suitable as a basis for the forwarding policy. The encounter utility value reflected by the social connection relationship between the two nodes is composed of the number of encounters and the attenuation of the two nodes, expressed as Eq. (1)

$$encntUtil(v_i, v_j) = numEncnt(v_i, v_j) \times \frac{1}{(tsNow - tsLastEncnt(v_i, v_j) + 1)^\gamma} \quad (1)$$

where $numEncnt(v_i, v_j)$ is the number of encounters between node v_i and node v_j , $tsNow$ is the current simulation time, $tsLastEncnt(v_i, v_j)$ is the most recent encounter time of node v_i and node v_j , γ is the attenuation factor, an adjustable parameter.

3.3 Routing Mechanism

The fountain-encoded packet is continuously sent until the ACK packet of the destination node is received. This method causes considerable overhead, and the reply of the ACK packet may also be interfered by the interrupt path or long delay. Therefore, the single-hop acknowledgement retransmission mechanism, instead of end-to-end confirmation retransmission mechanism is utilized to achieve efficient data transfer. After receiving the acknowledgment message from the neighbor node, the source node deletes the corresponding message in the cache, otherwise it retransmits after a time.

The routing mechanism of the proposed protocol is based on the above utility value and fountain code. Next, the route initialization, the source node sending process, and the selection of the next-hop node are sequentially explained.

Route Initialization

The route initialization is the process of sending broadcast messages and updating local

data. After a period of broadcast message transmission and reception, each node obtains the information of the current one-hop neighbor node, and also accumulates historical encounter information with some nodes of the network, preparing for the selection of the next-hop node.

Sending Process of Source Node

When the source node S sends data to the destination node D , consisting of k original packets, any number of fountain-coded packets can be generated. However, in order to improve end-to-end transmission performance, the amount of fountain-coded packets is controlled at the source node. According to the characteristics of the fountain code, the destination node receives at least $X \geq K = k(1 + \varepsilon)$ coded packets to decode and recover the original data completely, where K is the minimum number of correctly decoded packets, related to the nature of the fountain code used. Due to the existence of the packet loss rate q in the network, consider redundancy at the source node. Taken together, $M \geq K(1 + q) = k(1 + \varepsilon)(1 + q)$ fountain-coded packets are sent by the source node.

Selection of the Next-Hop Node

When the source node and the intermediate node perform message forwarding, n nodes are selected from the current neighbor nodes $NB_j(1 \leq j \leq m)$ as the next-hop nodes, which is denoted as $NB_i(1 \leq i \leq n)$. The selection follows the six criteria below.

- a) The utility value of the selected next-hop node with respect to the destination node is greater than the utility value of the current node with respect to the destination node;

$$\forall U_{NH_i}^D > U_M^D \quad (2)$$

- b) The utility value of the selected next-hop node with respect to the destination node is the largest among all utility values of neighbor nodes with respect to the destination node;

$$U_{NH_i}^D \geq \max(U_{NB_i(\forall NB_i \in NB \setminus NH)}^D) \quad (3)$$

- c) Whether the alternate next hop nodes include the last hop node of the message depends on the reception time. If the interval exceeds the threshold, the last hop node is optional; if the interval is less than the threshold, the last hop node is excluded from the candidate nodes;
- d) The amount of data transferred on each path is allocated according to the utility value of the selected next-hop node. The percentage of data sent to the next hop node is proportional to the corresponding utility value;

$$P_i \propto U_{NH_i}^D \quad (4)$$

- e) The number of next-hop nodes selected at each intermediate node is not equal, and may be only one;
- f) When there is not any next-hop node that meet the above principles, the current node caches the message.

4 Performance Evaluation

4.1 Simulation Scenario and Parameter Settings

This section evaluates and compares the performance of the PFC-DRP protocol through simulation. The evaluation indicators include Delivery Ratio, Average Delay, Average Number of Hops, and Delivery Cost.

The discrete event simulator OMNeT++ is selected to evaluate the performance of routing protocols. The node mobility model is Community-based Mobility Model (CMM) [6]. The simulation scenario is that the terminal devices carried by the staff interact in a large conference. The internal facilities of the venue interfere with or even block the signals of the communication terminals, so the links between the nodes are in a state of intermittent and consistent with the characteristics of the DTNs. Table 2 summarizes the default parameter settings, and Fig. 2 presents the simulation scenario diagram.

Table 2. Parameters in the PFC-DRP Protocol Simulation

Parameters of simulation scenario	Default Value
Total simulation time	4 h
Simulation area size	1000 m * 1000 m, 2000 m * 2000 m
Number of nodes	100
Communication range of nodes	40 m
Motion speed of nodes	0–6 m/s
Application layer message generation time range	600 s–700 s
Application layer message generation interval	0.5 s
Local state probability of nodes p_l	0.0
Roaming state probability of nodes p_r	1.0
Hello message sending interval	5 s
Retransmission interval of one-hop confirmation	2.5 s
Expiration time of neighbor information	10 s
Expiration time of encounter information	3600 s
Fountain code decoding efficiency ε	5%

Constrain the same application layer raw data in the simulation. For the PFC-DRP protocol, the total amount of data sent is greater than other non-encoded routing protocols. The data redundancy is related to the efficiency of the fountain code used. Set the fountain encoding overhead to 5% in this simulation.

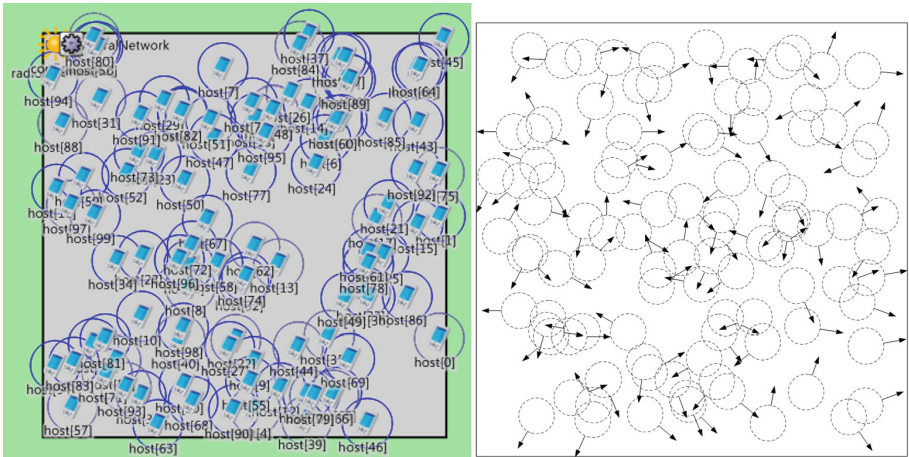

Fig. 2. DTNs Simulation Scenario

4.2 Results

This section first evaluates the performance of the PFC-DRP protocol as the limitation of message TTL (Time To Live) changes, and compares it with other classic routing protocols to examine the validity of the PFC-DRP protocol; then evaluates the PFC-DRP protocol under various network traffic conditions, and determine the operating efficiency of the PFC-DRP protocol through comparison.

Protocols selected for comparison are the proposed protocols, TSRouting, BubbleRap, GreedyAll, Fresh, and Random. Both TSRouting and PFC-DRP use the same utility value, while the PFC-DRP protocol adopts a multipathing mechanism and fountain encoding. The routing metric of BubbleRap is the social centrality [8]. In the Greedy-All protocol [9], messages are forwarded to nodes that have more encounters with other nodes in the network. The Fresh protocol [10] stipulates that the message is forwarded to the node that is closer to the destination node for the last contact. In the Random route, the message is randomly forwarded to the encountering node.

We evaluate the performance of the PFC-DPR protocol as the limitation of message TTL changes, and compare it with other classic routing protocols to examine the validity of the PFC-DRP protocol.

From Fig. 3, the PFC-DRP protocol and the Fresh protocol increase with increasing TTL, the delivery ratio reaches 100%, and other protocols reach 75%–90%.

According to Fig. 4, the average latency of the PFC-DRP protocol is about 10% lower than the Fresh protocol at the same delivery ratio, and is also at a low level in all protocols.

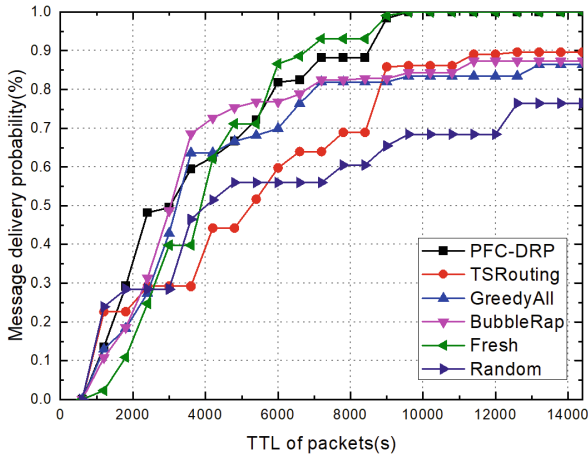

Fig. 3. Message delivery probability of different protocols vs TTL of packets

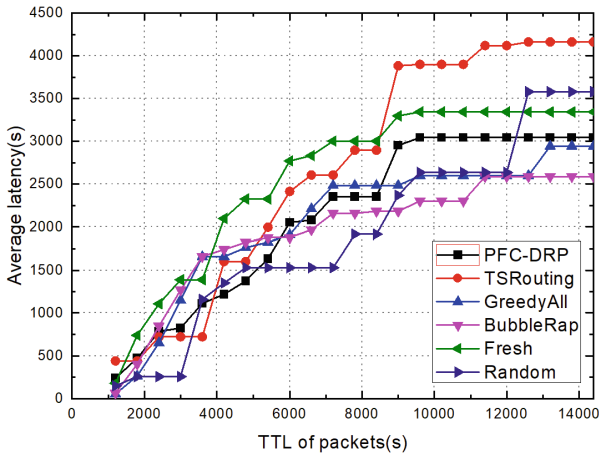

Fig. 4. Message average latency of different protocols vs TTL of packets

As seen in Fig. 5, the average number of hops of the PFC-DRP protocol is the lowest among all protocols.

Figure 6 shows that the message delivery overhead of the PFC-DRP protocol is also lower than other protocols.

In summary, although the PFC-DRP protocol increases the total network transmission traffic due to fountain coding, it can still achieve the highest delivery performance and the lowest delivery overhead. Compared with the TSRouting protocol with the same utility value, the PFC-DRP protocol improves the end-to-end delivery ratio and reduces the delivery cost.

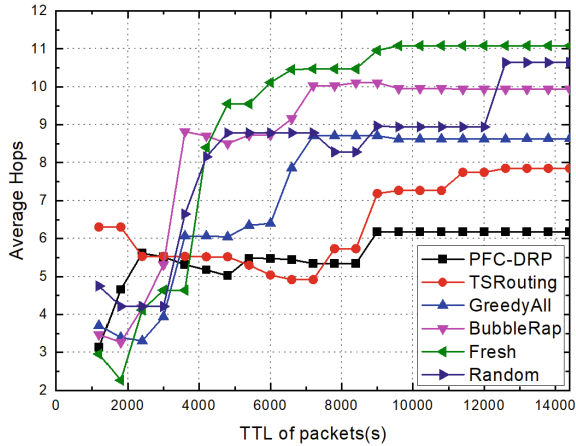

Fig. 5. Average hops vs TTL of packets

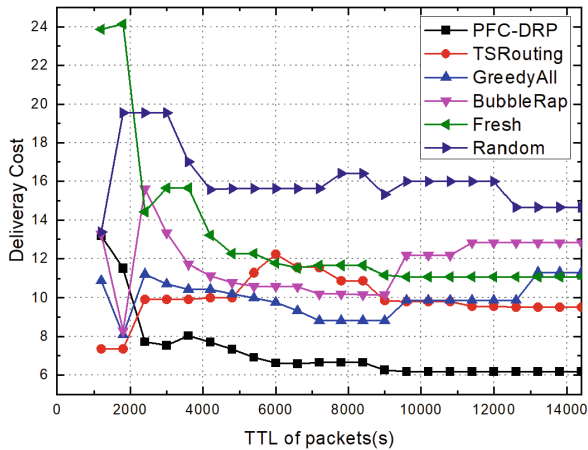

Fig. 6. Delivery Cost vs TTL of packets

As a conclusion, the percolation transmission mechanism in the PFC-DRP protocol is well suited to the network congestion caused by the increase in traffic volume. By distributing the data transmitted to the same destination on the multipath, congestion caused by the excessive pressure of the single node is avoided. It guarantees a higher level of messages delivery in the network.

5 Conclusions

In this paper, from the perspective of efficient transmission and data security, a DTNs routing protocol based on percolation technology and fountain code is proposed. This protocol combines the fountain coding at the source node and multipath transmission

techniques. By evaluating the protocol in OMNeT++, the protocol fully utilizes the multi-path resources of the network, effectively improves the end-to-end transmission performance, and ensures the security of data transmission.

References

1. Khabbaz, M., Assi, C., Fawaz, W.: Disruption-tolerant networking: a comprehensive survey on recent developments and persisting challenges. *IEEE Commun. Surv. Tutor.* **14**(2), 607–640 (2012)
2. Zhang, Z.: Routing in intermittently connected mobile ad hoc networks and delay tolerant networks: Overview and challenges. *IEEE Commun. Surv.* **8**(1), 24–37 (2006)
3. Cao, Y., Sun, Z.: Routing in delay/disruption tolerant networks: a taxonomy, survey and challenges. *IEEE Commun. Surv. Tutor.* **15**(2), 654–677 (2013)
4. Cao, Y., Wei, K., Min, Weng, J., Yang, X., Sun, Z.: A geographic multicopy routing scheme for DTNs With heterogeneous mobility. *IEEE Syst. J.* **12**(1), 790–801 (2018)
5. Le, T., Gerla, M.: Social-Distance based anycast routing in Delay Tolerant Networks. In: *Mediterranean Ad Hoc Networking Workshop (Med-Hoc-Net)*, pp.1–7. IEEE, Vilanova i la Geltru, Spain (2016)
6. Vazintari, A., Cottis, P.G.: Mobility management in energy constrained self-organizing delay tolerant networks: an autonomic scheme based on game theory. *IEEE Trans. Mob. Comput.* **15**(6), 1401–1411 (2016)
7. Pinto, P.C., Win, M.Z.: Percolation and connectivity in the intrinsically secure communications graph. *IEEE Trans. Inf. Theory* **58**(3), 1716–1730 (2012)
8. Hui, P., Crowcroft, J., Yoneki, E.: BUBBLE rap: social-based forwarding in delay-tolerant networks. *IEEE Trans. Mob. Comput.* **10**(11), 1576–1589 (2011)
9. Erramilli, V., Chaintreau, A., Crovella, M.: Diversity of forwarding paths in pocket switched networks. In: *Proceedings of the ACM SIGCOMM Internet Measurement Conference, IMC*, San Diego, USA, vol. 7, no. 1, pp.161–174. ACM (2007)
10. Dubois-Ferriere, H., Grossglauser, M., Vetterli, M.: Age matters: efficient route discovery in mobile ad hoc networks using encounter ages. In: *ACM International Symposium on Mobile Ad Hoc Networking & Computing (MobiHoc)*, Annapolis, Maryland, USA, pp.257–266. ACM (2003)