



Design the Tunable Wideband Filter for DDS+PLL Hybrid Frequency Synthesizer

Yuxin Zhou, Shaoting Cheng, and Xuemei Lei^(✉)

Inner Mongolia University, Hohhot 010021, China
ndlxm@imu.edu.cn

Abstract. In this paper, the tunable wideband bandpass filter is designed, which is used in hybrid frequency synthesizer of PLL+DDS mixing in the outside of the feedback loop. The channels of tunable wideband bandpass filter is chosen by two ADGM1304 single-pole, four-throw (SP4T) MEMS switch. And they are integrated on a high-frequency board with a substrate of Ro4350B. The central frequency of bandpass filter is 2.32 GHz, 2.38 GHz, 2.44 GHz and 2.5 GHz respectively. A wideband filter with adjustable center frequency is designed and the bandwidth is up to 240 MHz. Finally, physical tests show the spurious components and unwanted spectral components, especially near-end spurs at the center frequency are removed basically by the tunable broadband bandpass filter.

Keywords: Phase-lock-loop (PLL) · Direct digital synthesis (DDS) · Bandpass filter · Mixer · SP4T MEMS switch

1 Introduction

With the development of communication and remote sensing technology, it is light weight, low cost and easy processing that microstrip filters are widely used in microwave plane circuits and even microwave integrated circuits [1]. Bandpass filter is a fundamental component of wireless communication system that delivers signal within its bandwidth and attenuates signals outside its bandwidth, enhancing the desired frequency component [2]. And the high performance and compact bandpass filters have been widely used in modern communication systems. This kind of filters can be realized by using the methods of high selectivity and harmonic suppression [3]. A multi-layered substrate filter structure is observed that if the split gap width of the microstrip line increases, there is a better suppression of harmonics in the response of the bandpass filter in [4]. In modern wireless communication systems, compact bandpass filters with low insertion loss, dual-band frequency responses and high frequency band selectivity have gained more attention in recent years, which can reduce the complexity and cost of front-end systems [5]. Especially parallel coupled microstrip line structures have gained great interests in modern communication systems [6]. Parallel coupled microstrip line can realize narrow band filter. Characteristic impedance is the most important feature of microstrip line [7]. Parallel coupled microstrip bandpass filter has become one of the

most commonly used filters for RF front end because of its planar structure and simple design method [8].

Frequency synthesizer is a key component of modern electronic equipment, which can provide a large number of local oscillator signals and carrier signals with high accuracy and fast conversion for communication equipment. It is an important part in modern electronic systems. PLL is good at spurious behavior and there is a shortage in frequency switch speed and frequency resolution [9]. DDS has the advantages of high frequency resolution and short frequency conversion time. Thus, the hybrid frequency synthesizer technology of combine PLL and DDS has become a new research field. And the hybrid frequency synthesizer of PLL+DDS mixing in the outside of the feedback loop can make full use of the characteristics of DDS's high resolution, PLL's high spectral purity, and high stability. But the obvious shortcomings of the structure hybrid frequency synthesizer is the output signal of DDS include spurious frequency and harmonic components so that the frequency components are very complex after mixing with the output signal of PLL so that the near-end spurious of DDS varies with the frequency of the output signal and it is difficult to filter out.

In this paper, we focus on the study of the tunable wideband bandpass filter in DDS+PLL hybrid frequency synthesizer with external loop mixing, mixer output, which include ADGM1304 SP4T MEMS switch and the microstrip line bandpass filter. The hybrid frequency synthesizer consists the mixer so that the spectrum has some new spur. And the near-end spurs are relatively large at the center frequency. Therefore, the bandwidth of the bandpass filter provided cannot be too wide, and stop-band suppression are high. So we design a parallel coupled microstrip line bandpass filter with adjustable center frequency and its stopband attenuation amplitude is greater than 50 dB. The design of the tunable wideband filter applied in the hybrid frequency synthesizer of PLL+DDS mixing in the outside of the feedback loop can remove the spurious and unwanted spectral components to improve the spectral purity of the hybrid frequency synthesizer.

2 Analysis the Hybrid Frequency Synthesizer of PLL+DDS

The hybrid frequency synthesizer mixing in the outside of the feedback loop is mainly composed of phase-locked loop (PLL) module, direct digital frequency synthesizer (DDS) module, mixer (Mixer) module and band-pass filter (BPF) module (see Fig. 1).

The mixer plays the role of spectrum shift in the system, SP4T MEMS switches act as strobe filters for test channels. The last-stage bandpass filter determines the output bandwidth and ability of spurious suppression in entire system.

The phase locked loop (PLL) adopts ADF4351 chip, which a fundamental output frequency range is from 35 MHz to 4400 MHz. The input reference clock of ADF4351 is provided by the active crystal oscillator with a frequency of 25 MHz. The chip is operating with a power supply of 3 V to 3.6 V. The main objective is to provide a communication transceiver with low cost and lower power dissipation [10].

The direct digital synthesis (DDS) adopts AD9910 chip. The AD9910 supports sampling rates up to 1 GSPS. The output frequency range of DDS is from 400 MHz to 6 GHz. The DDS provides fast frequency hopping and frequency tuning resolution with its 32-bit accumulator. AD9910 uses the voltage of 1.8 V and 3.3 V to supply power.

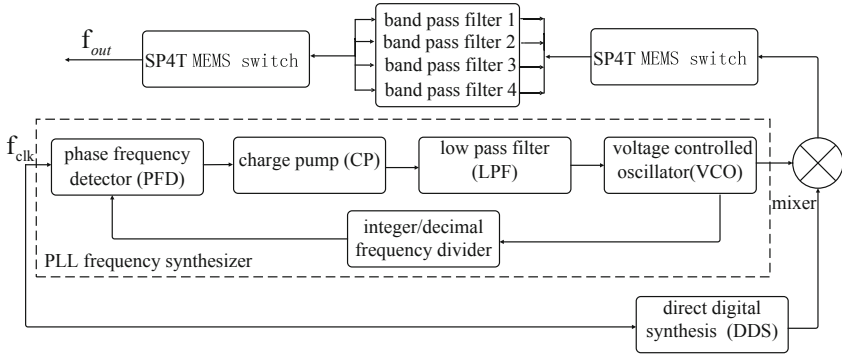

Fig. 1. The hybrid frequency synthesizer structure of PLL+DDS mixing in the outside of the feedback loop

The mixer adopts the ADL5375 chip, which only one input is mixed with the local oscillator and the other is connected to 50 Ω load. PLL provides local oscillator (LO) signal and DDS provides intermediate frequency (IF) signals for mixer. ADL5375 is powered by a 5 V ADP3334 low-dropout regulator (LDO), which reduces the effect of power management on the phase noise of the device.

The SP4T MEMS switch uses the ADGM1304 chip. The SP4T switch provides optimum performance in terms of bandwidth, power handling capability and linearity for RF applications. The power supply voltage needs to be 3.1 V to 3.3 V, the working frequency range is from 0 Hz/dc to 14 GHz, the switching time is 30 μs and the resistance of the conduction is 1.6 Ω.

The indicators of the hybrid frequency synthesizer and tunable wideband bandpass filter are provided in Table 1 and Table 2. These indicators demonstrate that it is necessary for the bandpass filter to have a steep transitional zone and high selectivity. Therefore, the difficulty of the bandpass filter in design is increased.

Table 1. The specific indicators of the hybrid frequency synthesizer

Parameters	Values
The adjustable resolution of the output frequency	1 Hz
The modulation period	us
The single point stability	1 Hz
The range of output power	-76 dBm ~ -64 dBm

Table 2. The design indicators of the tunable wideband bandpass filter

Parameters	Values
The center frequency of the tunable bandpass filter	2.32 GHz, 2.38 GHz, 2.44 GHz, 2.5 GHz
Stopband rejection of the filter	≥50 dBc (within 65 MHz)
The tunable passband range of the filter	2410 MHz ± 120 MHz

3 Design the Tunable Wideband Bandpass Filter

The design of the tunable wideband bandpass filter is based on a low-pass filter. The lumped parameter components and distributed parameter components can be obtained by a series of model transformations based on the low-pass filter. Since the center frequencies of the tunable wideband bandpass filters designed in this system are 2.32 GHz, 2.38 GHz, 2.44 GHz and 2.5 GHz respectively, the method of lumped parameter has better performance in low frequency band, and the theory of lumped parameter is used to design the bandpass filter.

However, converting from lumped bandpass filter to microstrip bandpass filter, it is necessary to make use of the resistive inverter. As shown in Eq. (1), the series resonator is converted into a parallel resonator. Each series resonator is replaced by two inverters and one parallel resonator (see Fig. 2)

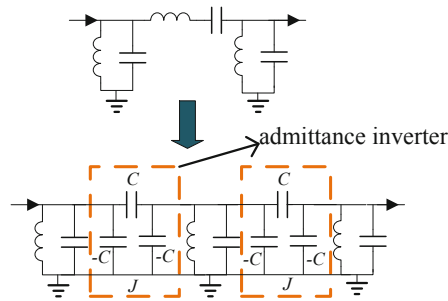

Fig. 2. Conversion diagram of series resonator

$$Z_{eq} = K^2 / Z \quad Y_{eq} = J^2 / Y \tag{1}$$

The design adopts the structure of bandpass filter consisting of cascaded coupled microstrip line nodes is shown (see Fig. 3).

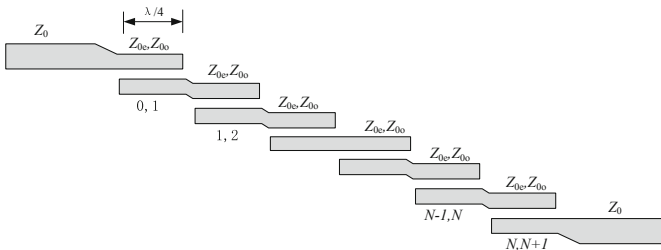

Fig. 3. Structure of fourth-order coupled microstrip bandpass filter

The length of each coupling unit in the filter is $1/4$ of the wavelength corresponding to the center frequency and it is shown (see Fig. 4).

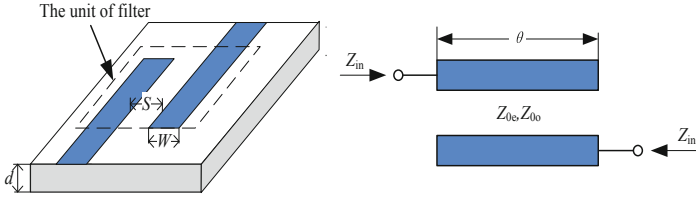

Fig. 4. The unit of coupled microstrip

The coupled microstrip line can be equivalent to the model (see Fig. 5).

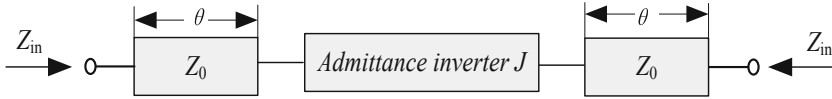

Fig. 5. Equivalent model of coupled microstrip

The plate of tunable wideband bandpass filter is selected by rogers_4350B, the dielectric constant is 3.66 (this value is selected according to the frequency of plate and the corresponding dielectric constant in the Rogers_4350B manual), the tangent loss is 0.0031, the thickness of the dielectric substrate is 0.762 mm and the copper thickness is 0.035 mm. The specific steps for designing a microstrip edge-coupled bandpass filter are as follows [11, 12]:

1. According to stopband suppression, ripple parameters, passband range and Tables 5.2 to 5.6 in Ref. [10], the normalized parameters of the low-pass prototype devices are $g_0 = 1, g_1 = 1.6703, g_2 = 1.1926, g_3 = 2.3661, g_4 = 0.8419, g_5 = 1.9841$ respectively.
2. According to the requirement of bandwidth in the design, the bandwidth of every bandpass filter is 60 MHz, and the center frequency is calculated by $\omega_0 = (\omega_L + \omega_U)/2$. According to the normalized bandwidth formula $BW = (\omega_U - \omega_L)/\omega_0$ of filter, the normalized bandwidth is determined. The following parameters are recalculated by the bandwidth, as shown in the Eq. (2). These parameters can be used to calculate the odd model impedance of the transmission line by Eq. (3) and the characteristic impedance of the even mode is as Eq. (4).

$$J_{0,1} = \frac{1}{Z_0} \sqrt{\frac{\pi BW}{2g_0 g_1}} \quad J_{i,i+1} = \frac{1}{Z_0} \frac{\pi BW}{2\sqrt{g_i g_{i+1}}} \quad J_{N,N+1} = \frac{1}{Z_0} \sqrt{\frac{\pi BW}{2g_N g_{N+1}}} \quad (2)$$

$$Z_{0o|i,i+1} = Z_0 \left[1 - Z_0 J_{i,i+1} + (Z_0 J_{i,i+1})^2 \right] \quad (3)$$

$$Z_{0e|i,i+1} = Z_0 \left[1 + Z_0 J_{i,i+1} + (Z_0 J_{i,i+1})^2 \right] \quad (4)$$

Where, the subscript $(i, i + 1)$ represent the coupled microstrip line elements. Z_0 is the characteristic impedance of the microstrip line bandpass filter at the input and output ports. In this design, Z_0 is 50Ω .

Therefore, the relevant parameter $Z_0 J_{i,i+1}$ is calculated according to Eq. (2) and the characteristic impedances of odd and even modes are calculated by using Eqs. (3) and (4). The calculated values are shown in Table 3.

Table 3. Parameter values of tunable wideband bandpass filter

The center frequency are 2.32/2.38/2.44/2.5 GHz				
$i, i + 1$	$Z_0 J_{i,i+1}$	$Z_0 (\Omega)$	$Z_{0o} (\Omega)$	$Z_{0e} (\Omega)$
0, 1	0.155/0.153/0.151/0.150	50	43.43/43.489/43.57/43.62	58.997/58.88/58.74/58.64
1, 2	0.028/0.028/0.027/0.026	50	48.606/48.639/48.68/48.7	51.47/51.44/51.396/51.37
2, 3	0.024/0.023/0.022/0.022	50	48.824/48.85/48.88/48.91	51.234/51.20/51.17/51.15
3, 4	0.028/0.028/0.027/0.026	50	48.606/48.639/48.68/48.7	51.47/51.44/51.396/51.37
4, 5	0.155/0.153/0.151/0.150	50	43.43/43.489/43.57/43.62	58.997/58.88/58.74/58.64

3. Considering the edge effect of the microstrip line, the size of each microstrip line needs to be corrected. The size of the microstrip line calculated by the previous step may not meet the requirements and it need to be optimized by using the optimization tools in ADS. The optimized size of the microstrip line is shown in Table 4.

Table 4. Optimized size of tunable wideband bandpass filter

The center frequency are 2.32/2.38/2.44/2.5 GHz			
Line description	Width (mm)	Gap (mm)	Length (mm)
50 ohm-line	1.627/1.627/1.627/1.627	–	19.20/18.72/18.25/17.82
Coupled lines 1 and 5	1.530/1.602/1.765/1.982	0.67/0.51/0.307/0.407	21.673/16.36/13.718/17.234
Coupled lines 2 and 4	2.046/2.314/4.019/2.667	1.949/2.615/2.8/2.48	15.366/20.483/23.553/17.00
Coupled lines 3	3.392/1.652/1.956/2.678	2.25/2.38/2.35/2.95	22.453/16.40/13.688/17.068

4 Test Results

In this design, the PLL generates local oscillation frequencies are 2195 MHz, 2255 MHz, 2315 MHz, and 2375 MHz, respectively. DDS output IF signal from 115 MHz to 135 MHz. The structure diagram is shown in Fig. 6. Physical picture of tunable wideband bandpass filter is shown in Fig. 7. The size of tunable wideband bandpass filter is $288.18 * 140.84 * 0.762 \text{ mm}^3$.

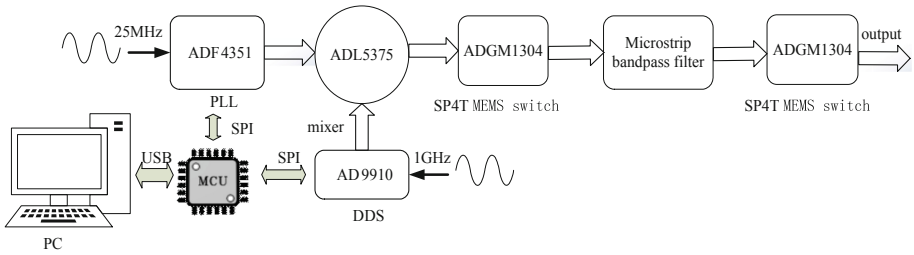

Fig. 6. The structure diagram of each module in the system.

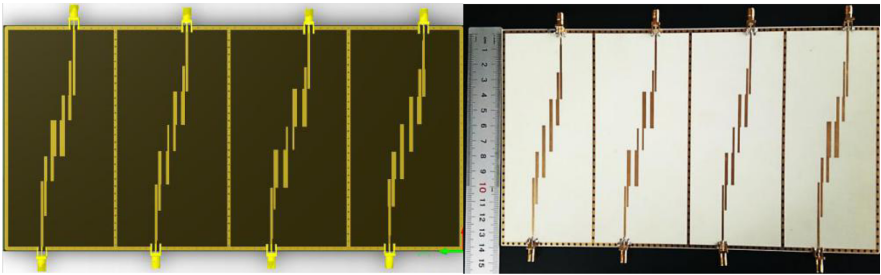

Fig. 7. Physical picture of tunable wideband bandpass filter

The tunable wideband bandpass filter are tested by an Agilent E5062A vector network analyzer. The test results are shown in Fig. 8.

The center frequency of filter is 2.32 GHz, 2.38 GHz and 2.5 GHz and it can completely realize the preset target and filter the spurious spectrum effectively. The test results show the filter with center frequency of 2.44 GHz is slightly deviated, but other spurious spectrum is also filtered out. The reason is the tunable wideband bandpass filter is composed of four filters with different central frequencies. And in order to connect the SMA connector to the real edge, it is necessary to add a different length of microstrip line on the layout, and results in a great edge effect at the open end of the coupling element microstrip line.

In order to verify the performance of the tunable wideband bandpass, the output spectrum of the hybrid frequency synthesizer is tested by spectrum analyzer ADVANTEST R3131A. The result of the test is shown in Fig. 9. The PLL generates local oscillator frequencies of 2195 MHz, 2255 MHz, 2315 MHz, and 2375 MHz respectively, the intermediate frequency signal of 125 MHz is output by DDS.

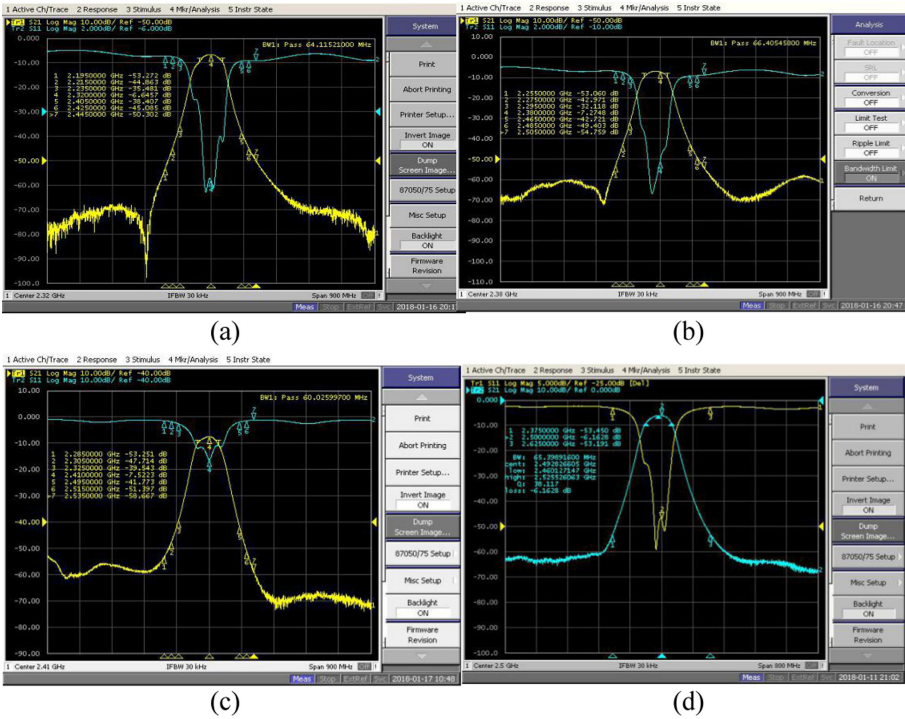
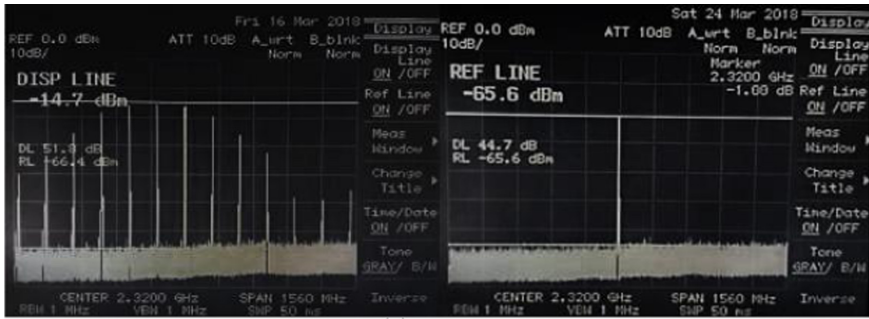

Fig. 8. Test results of tunable wideband bandpass filter. (a) The center frequency is 2.32 GHz. (b) The center frequency is 2.38 GHz. (c) The center frequency is 2.41 GHz. (d) The center frequency is 2.5 GHz.

When the tunable wideband bandpass filter is unconnected, the test results shown the output spectrums of hybrid frequency synthesizer are special complicated and include a number of spur. After the spectrum of DDS and PLL are mixed, the new spurs are generated and the near end spurs are relatively large. When the tunable wideband bandpass filter is connected, the test results shown the spurious components and unwanted frequency components are removed. It meets the design requirements of index and the expected design goal is realized.

The power values of the near-end spurs and the main frequency spectrum are tested. The range of tests from 2.29 GHz to 2.53 GHz and the interval of main frequency spectrum is 10 MHz. The power of main frequency fluctuates slightly at 2.45 GHz (see Fig. 10). The reason is that tunable wideband bandpass filter is shifted 30 MHz to the left at the frequency of 2.44 GHz and tunable wideband bandpass filter is a passive microstrip line edge coupled bandpass filter, which has a certain attenuation in the band. The frequency points of near-end spurs are concentrated near 2.41 GHz. The reason is that the influence of DDS on near-end spurs is greater than that of PLL. However, DDS is fixed to 125 MHz, and PLL's step is 10 MHz in this test, so when testing the spurious values at different frequencies, the frequency conversion of the PLL is the main influence on spurs. Therefore, the frequency values of near-end spurs is basically unchanged.



(a)

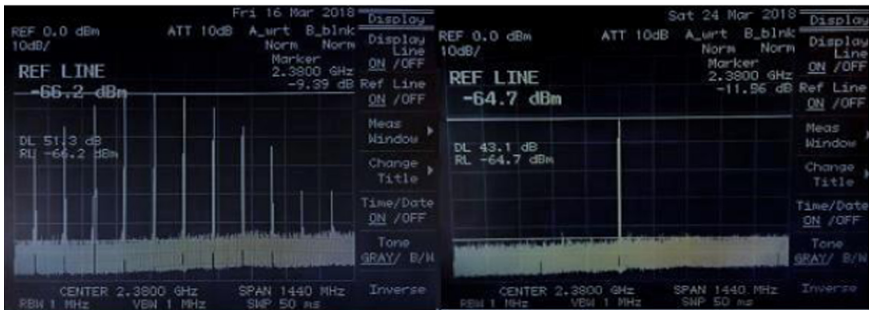

(b)

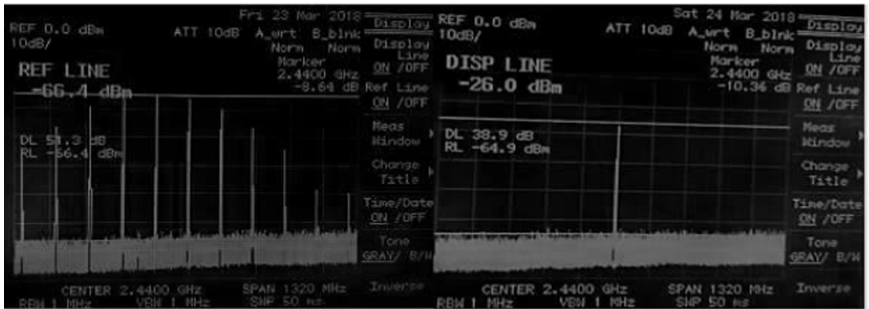

(c)

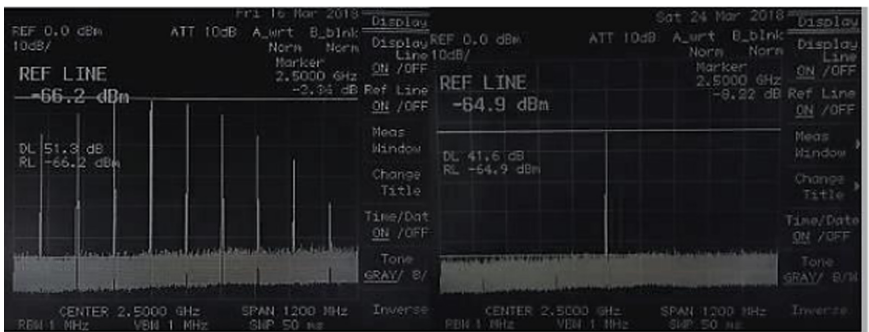

(d)

Fig. 9. The output spectrum distribution graph of the system. a) Central frequency is 2.32 GHz; b) Central frequency is 2.38 GHz; c) Central frequency is 2.44 GHz; d) Central frequency is 2.5 GHz.

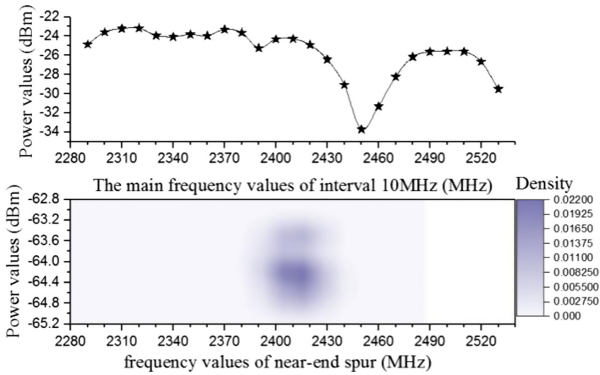

Fig. 10. Test power of the near-end spurs and main frequency

The power difference between the main frequency and the near-end spurs is about 40 dB. The spurs suppression is effective by tunable wideband bandpass filter. It is demonstrated that the tunable wideband bandpass filter achieves the best filtering effect.

5 Conclusion

In this paper, the tunable wideband bandpass filter is designed in hybrid frequency synthesizer of PLL+DDS mixing in the outside of the feedback loop. The major design difficulties of the tunable wideband bandpass filter is shown in the following:

- I. It is difficult to filter the spurs, which is brought about by the DDS spur;
- II. It is difficult to keep the band of output signals and suppress the near-end spur, which it is necessary that the tunable wideband bandpass filter must have a steep transitional zone.

In order to meet the demand of the hybrid frequency synthesizer of PLL+DDS mixing in the outside of the feedback loop, the central frequency of bandpass filter is 2.32 GHz, 2.38 GHz, 2.44 GHz and 2.5 GHz respectively. And the bandwidth is up to 240 MHz. Finally, physical tests show the spurious components and unwanted spectral components, especially near-end spurs at the center frequency are suppressed effectively compression by the tunable wideband bandpass filter.

References

1. Yang, G.M., et al.: Miniaturized Antennas and planar bandpass filters with self-biased NiCo-Ferrite films. *IEEE Trans. Magn.* **45**(10), 4191–4194 (2009)
2. Yang, S., et al.: Design and simulation of a parallel coupled microstrip bandpass filter. In: *Southeastcon IEEE*, p. 1 (2014). <https://doi.org/10.1109/secon.2014.695069-5>
3. Marimuthu, J., et al.: Compact bandpass filter with multiple harmonics suppression using folded parallel coupled microstrip lines. In: *Microwave Conference IEEE*, p. 1 (2016) <https://doi.org/10.1109/apmc.2015.7413198>

4. Choudhury, S.R., Sengupta, A., Das, S.: Bandpass filters using multilayered microstrip structures. In: 2018 Emerging Trends in Electronic Devices and Computational Techniques (EDCT), Kolkata, pp. 1–3 (2018). <https://doi.org/10.1109/edct.2018.8405065>
5. Munir, A.: Development of dual-band microstrip bandpass filter based on split ring resonator. In: 2016 International Conference on Electromagnetics in Advanced Applications (ICEAA), Cairns, QLD, pp. 712–715 (2016). <https://doi.org/10.1109/iceaa.2016.7731498>
6. Sahin, E.G., Gorur, A.K., Karpuz, C., Gorur, A.: Design of wideband bandpass filters using parallel-coupled asymmetric three line structures with adjustment elements. In: 2019 49th European Microwave Conference (EuMC), Paris, France, pp. 464–467 (2019). <https://doi.org/10.23919/eumc.2019.8910941>
7. Zhang, M., et al.: The simulation of microstrip band pass filters based on AD-S. In: ISAPE. International Conference on IEEE, p. 909 (2012). <https://doi.org/10.1109/isape.2012.640892-0>
8. Tang, C., Hsu, Y.: A microstrip bandpass filter with ultra-wide stopband. *IEEE Trans. Microwave Theory Tech.* **56**(6), 1468–1472 (2008). <https://doi.org/10.1109/TMTT.2008.923900>
9. YongKe, L.: The design of wide BW frequency synthesizer based on the DDS&PLL hybrid method. In: 2009 9th International Conference on Electronic Measurement & Instruments, Beijing, pp. 2-689–2-692 (2009). <https://doi.org/10.1109/icemi.2009.5274484>
10. Gatti, R., et al.: Design of frequency synthesizer for wireless communication. In: 2017 2nd IEEE International Conference on Recent Trends in Electronics, Information & Communication Technology (RTEICT), Bangalore, pp. 1794–1798 (2017). <https://doi.org/10.1109/rteict.2017.8256908>
11. Ludwig, R., Bogdanov, G.: *RF Circuit Design: Theory and Applications*. 2nd edn., p. 172. Upper Saddle River (2000)
12. Ferh, A.E., Jleed, H.: Design, simulate and approximate parallel coupled microstrip band-pass filter at 2.4 GHz. In: 2014 World Congress on Computer Applications and Information Systems (WCCAIS), Hammamet, pp. 1–5 (2014). <https://doi.org/10.1109/wccais.2014.6916620>