

A Scheme to Support Mobility for IP based Sensor Networks

Mustafa Hasan GSIC, Ajou University, Suwon, Korea. +82-10-6872-6066 mhmunna@ gmail.com	Ali Hammad Akbar UET, Lahore, Pakistan +92-302-842-9653 ahakbar@ gmail.com	Hamid Mukhtar GSIC, Ajou University, Suwon, Korea. +82-10-7157-9876 hamid@ ajou.ac.kr	Ki-Hyung Kim ¹ GSIC, Ajou University, Suwon, Korea +82-31-219-2433 kkim86@ ajou.ac.kr	Dong-Wha Kim Agency for Defense Development, Korea. +82-2-3400-4978 dhkim@add.re.kr
---	---	--	---	---

ABSTRACT

Wireless Sensor Network (WSN) that comprise low end devices (power, battery, cost, and life) are becoming increasingly important because they are poised to render a broad range of military and other commercial applications such as in Personal Area Networks (PANs). Amongst the various tiers of network connectivity, it is the IP-based Internet access that has truly enabled the ubiquity of these PANs. As many exciting applications emerge, that benefit from such IP connectivity, their burgeoning role necessitates provisioning of these applications beyond their local vicinity—entailing mobility. In order to keep network connectivity intact especially while the sensor nodes move, definition and provision of a mobility scheme for such low end devices is a crucial problem. In this paper we have analyzed various mobility scenarios for the low end devices, specifically the IEEE802.15.4 devices. We have objectively analyzed the scalability of the system using the throughput and delay measures for benchmarking their performance under the influence of mobility. The several numerical results for various mobility scenarios substantially support the efficacy of our scheme.

Keywords

IP based Ubiquitous Sensor Network (IP-USN), Mobility of Sensor Nodes, Personal Area Network, Proxy MIPv6, HMIPv6, MIPv6, Network Mobility (NEMO) and scalability of Sensor Network.

1. INTRODUCTION

Modern IP enabled low cost, low power communication networks play an important role in the realization of truly ubiquitous environments by providing wireless connectivity in applications with relaxed throughput requirements. A practical and commercially viable manifestation of IP-based ubiquitous sensor networks (IP-USNs) is the 6LoWPAN [1] in which IEEE802.15.4 devices connect to the Internet through a gateway. In order to provide seamless mobility support to these kinds of low capable devices, a myriad of new challenges come up mainly from the disparate resource-constrained nature of these devices

¹Corresponding Author

Permission to make digital or hard copies of all or part of this work for personal or classroom use is granted without fee provided that copies are not made or distributed for profit or commercial advantage and that copies bear this notice and the full citation on the first page. To copy otherwise, or republish, to post on servers or to redistribute to lists, requires prior specific permission and/or a fee.

Infoscale2008, June 4-6, 2008, Vico Equense, Napoli, Italy.
Copyright 2008 ICST xxx-xxx-xx-xxxx-x

and the resource-intensive functions required for mobility. The challenges are exacerbated due to the heterogeneity in the mobility models themselves. For example the mobility of a single device within the PAN is different in extent and implications from the mobility of a group of PAN devices which move from one 6LoWPAN to another. While the former can be handled by PAN devices, the later needs coordination amongst two 6LoWPAN gateways. Although there are architectures of various kinds that address these mobility issues in great detail (discussed critically in the related work section), no singular architecture has exclusively addressed the granular differences between these variants of mobility and put forth recommendations to optimize their communication. Therefore, a scheme is still needed that

- a.) Provides an insight into different kinds of mobility models.
- b.) Demarcate their scope and effect on complexity in terms of computation and communication.
- c.) Define a utility-based complexity migration mechanism from low-end devices to high-end devices, and with performance analysis.
- d.) Define an analytical model to compare the feasibility.

In this paper we have tried to meet the above-mentioned requirements by investigating how such mobility models develop, and by substantiating their resource requirements. We have presented a scheme that exploits and extends the utility of network elements in supporting connectivity during mobility. Specifically, the scheme expedites the migration of responsibility to tackle mobility by invoking appropriate mobility-related modules in the network elements such as the sensor nodes, mobile routers and the gateways. Our proposed scheme handles all possible mobility scenarios with the minimal change in the already established mobility protocol. We actually haven't made a completely new protocol, but made the adjustment to effective solution for the sensor networks mobility scenarios.

The organization of the paper is as the following; in section II we discuss some of the formative research in mobility that is forging the state-of-the-art today. A scenario that purports possible mobility scenarios for the low-end devices is presented in section III. We define the responsibility and how it should be distributed across the network elements in section IV. A holistic solution that amicably meets the requirement specifications in the preceding section, is presented in V. We determine the analytical mode in

section VI. We evaluate the performance in section VII. Finally, we draw conclusion in section VIII.

2. Related Works

Our related work section is bipartite in nature, involving the analysis of the state-of-the-art in host based mobility and network based mobility. Our proposed scheme is related to IETF's ongoing research on different host based mobility such as Mobile IPv6 [2], Hierarchical MIPv6 [3] and Fast Mobile IPv6 [4]. Also the network based mobility such as Network Mobility (NEMO) [5] and Network Based Localize Mobility (NETLMM) [6].

2.1 Host Based Mobility

The host based mobility such as MIPv6, FMIPv6 and HMIPv6 was proposed by the Internet Engineering Task Force (IETF) to handle the seamless global mobility in IPv6 devices [17].

In *MIPv6*, when a node moves from one network to another, the node itself (Host) updates its current location through binding its home address to the current care of address through a binding update (BU). Also, to ensure a secure BU at the CN, the method used in MIPv6 called the "return routability" procedure. The basic return routability mechanism consists of two checks, namely 1) a home address check and 2) a Care of Address (CoA) check to guarantee the legitimacy of the MN. This procedure consists of the exchange of four messages with CN prior to sending the BU messages. The MN sends to the CN two messages at the same time: Home Test Init message via the HA and Care-of Test Init message directly. Upon the reception of each message, the CN sends back two messages to the MN: Home Test message via the HA and Care-of Test message directly, each containing a different token to be used by the MN to generate the binding management key. This binding management key is then used by the MN to send a verifiable BU to the CN. The handover process is illustrated in Fig. 1. Existing bindings become obsolete each time the MN moves to a new point of attachment and auto-configures a CoA. When this happens, the MN should immediately send out BUs to all correspondents with which it is actively communicating.

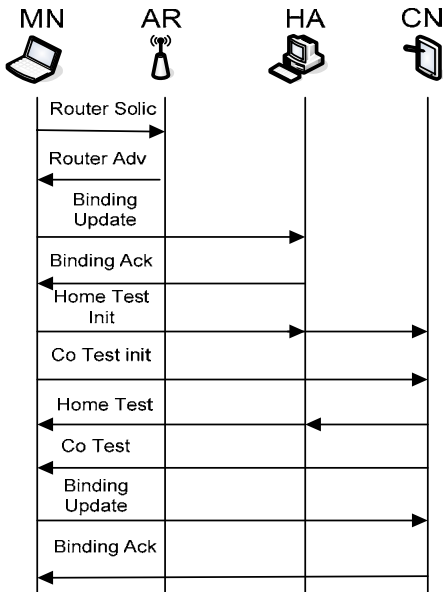

Figure 1: MIPv6 Handover Process

HMIPv6 is an enhancement of MIPv6 protocol, which aims to reduce the amount of signaling protocol required and improving handoff delays for mobile connections. Although it is not necessary for external hosts to be updated when an MN moves locally, these updates occur for both local and global movements. To solve this inefficient use of resources, in the case of local mobility, HMIPv6 adds another level on MIPv6, separating local mobility from global mobility. HMIPv6 introduces a new entity called mobile anchor point (MAP). The MAP replace the HA for local update and increase the utilization. As illustrated in Fig. 2, an MN entering a MAP domain receives router advertisements containing information on one or more local MAPs. The MN can bind its current location [on-link CoA (LCoA)] with an address on the MAP's subnet [regional CoA (RCoA)]. Acting as a local HA, the MAP receives all packets on behalf of the MN it is serving and encapsulates and forwards them directly to the MN's current address. If the MN changes its current address within a local MAP domain (LCoA), it only needs to register the new address with the MAP. The RCoA must be registered with CN and HA only when the MN moves outside a MAP domain, as shown in Fig. 3.

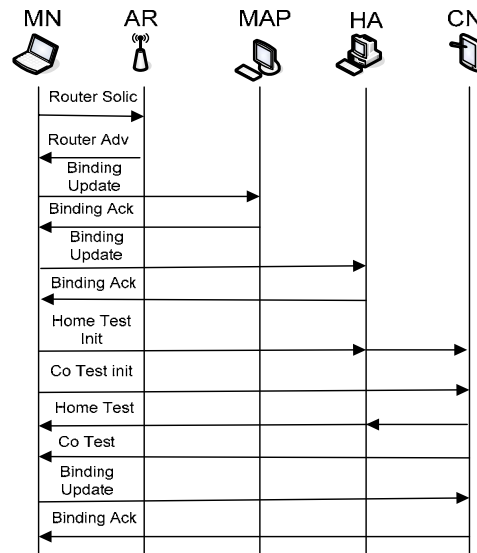

Figure 2: HMIPv6 Inter Handover Process

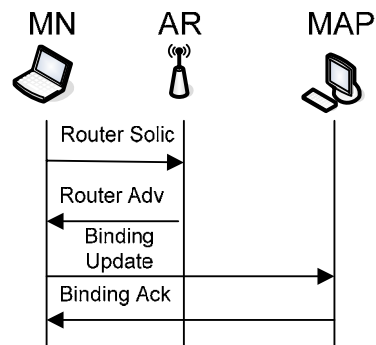

Figure 3: HMIPv6 Intra Handover Process

FMIPv6 is another enhancement of MIPv6, which aims to reduce handoff delays for mobile connections by delivering the packet in the new point of attachment at the earliest. There are two modes of operations: predictive and reactive. In both modes, the MN sends a router solicitation for proxy advertisement

(RtSolPr) to its current access router (AR). The AR replies with a proxy router advertisement (PrRtAdv) that provides to the MN information about the neighboring AR so that the MN can formulate a prospective new CoA. Then, the MN sends a fast BU (FBU) that allows the previous AR to tunnel packets destined to the MN from the old CoA to the new CoA.

However, the trends of host based mobility suggest that this approaches keen to solve the issues of quick handoff and reliability, but attending the problem of resource constrain devices as sensor network. Thus those protocols are battery exhaustive and heavily process dependent for the host.

2.2 Network Based Mobility

On the other hand, the Network based mobility, such as Network mobility (NEMO) and Network based localized mobility (NETLMM) also proposed by the IETF, is to take the mobility responsibility to the network on behalf of the host. In NEMO basic support, the mobility is handled by the mobile router on behalf of the nodes.

In *NEMO* it has been assumed that the sensor nodes will move together under mobile router, which is going to handle the overall mobility mechanism. However, the *NEMO* is unable to provide the solution for ubiquitous mobility, which includes the individual or scattered mobility of the host. Figure 4 describe the signaling for *NEMO*.

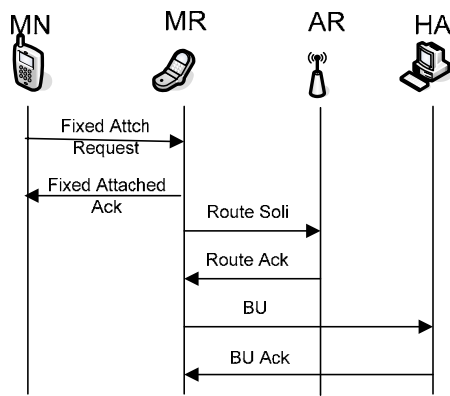

Figure 4: NEMO Handover

The *NETLMM* is the enhancement of MIPv6 to maintain the localized mobility. *NETLMM* introduce several new entities such as Localized Mobility Anchors (LMAs) within the backbone network maintain a collection of routes for individual mobile nodes within the localized mobility management domain. The other new entity Mobile Access Gateway (MAG) has three functional roles, 1. Detecting the MN's movement and initiating the signaling with the MN's LMA for updating the route to the NM's home address, 2. Setting up the data path for enabling the mobile node to use its home address for communication from the access link; 3. emulation of the MN's home link on the access link. Among different operational solution of *NETLMM*, Proxy based MIPv6 (PMIPv6) is the more suitable. In PMIPv6 protocol operation consists of five phases. The first phase is Access Authentication, which ensure the valid MN using the AAA-server. In second phase MAG sends a Proxy Binding Update (BU) request to the LMA in order to register the current point of attachment of the MN. In the third phase is the MAG emulating the MN's home interface on the access interface. In forth the

MN's interface will be configured either by statefull or stateless address configuration methods. Lastly, for packet routing the LMA will route all received packets over the established tunnel to the MAG. The MAG will turn route these packets to the mobile node. Figure 5 shows the signaling for *NETLMM* (PMIPv6).

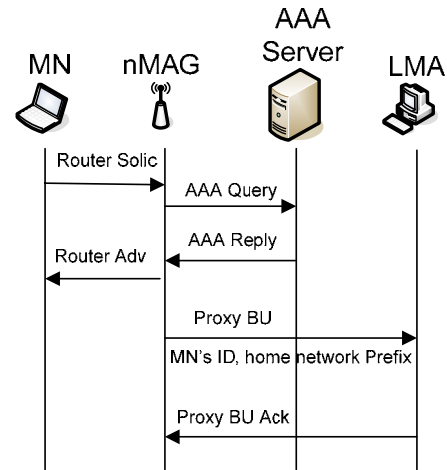

Figure 5: PMIPv6 Handover Process

Even though, this network based mobility targets to reduce the process burden from the host, but, it unable to provide solution for all kind of mobility scenarios. Also it introduces a lot of fundamental change in architecture by adding new network entity to deploy. Moreover, *NETLMM* was not targeted specifically for sensor network, thus it has some short coming to support sensor network.

Our schemes primary goal is to provide mobility for all possible mobility scenarios can be possible for sensor network, with minimal change in the already established mobility protocols. The other [15][16] Approaches for IP mobility unable to provide the solutions considering the energy constrain.

3. Mobility Scenarios and Classification

In this section, we present mobility scenarios to characterize their effect on the resource requirements. After this section, we would have tangible classification of mobility to lay out our approach.

The following scenario comprises two views, micro- and macro, each aimed at highlighting distinctive variants of mobility. Consider a military application, involving ground combat scenario, wherein troops are belonging to different command authorities. The troops in PAN 'A' are connected to the internet via the mobile router and the IP-gateway. Similarly, the nodes in PAN 'B' are connected to the Internet through the PAN coordinator and the IP-gateway. In the macro-view, there are two IP-gateways. Initially, PAN 'A' and PAN 'B' are connected to IP-gateway I, while sometime at the later stage, these two PANs move to IP-gateway II, generating some unique mobility scenarios. Throughout all the scenarios (□) refers to the point of departure and (•) is the new arrival location. As can be seen from the figure, following are the variants of mobility.

A. Intra-PAN node mobility: Consider PAN 'A', wherein each soldier is operating within his designated position. When a soldier moves to new location, it must be communicated to the mobile router (or PAN coordinator) so that routing may be facilitated.

B. Inter-PAN node mobility: When the soldier moves from PAN 'A' to PAN 'B', a handover is needed in this case and the prefix of the node also changes.

C. Router mobility: In this scenario the router can be mobile, while there are multiple mobile routers which can serve the purpose of efficient routing and fault tolerance.

D. Network mobility: In this mobility scenario, the mobile router along with its associated nodes migrates from one IP-gateway to the other. The handover is handled by the router and is transparent to all its subordinate nodes. The scenario is quite similar to NEMO.

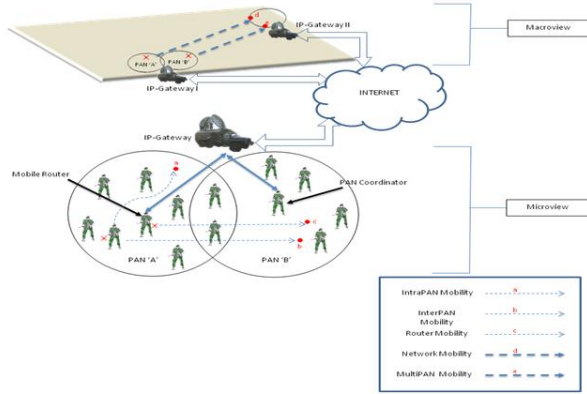

Figure 6: Scenarios Overview

E. Multiple-PAN mobility: A group of PANs moves without the support of the mobile router from the jurisdiction of one 6LoWPAN gateway to the other.

F. Special case—Nodes' mobility in sleep mode: In sensor networks the nodes can periodically go to sleep state in order to save energy and increase the network lifetime. Such a behavior may be expected during all the intra- and inter-PAN mobility scenarios.

4. Approach

In this section we identify the network entities that carry most of the load incurred during each mobility scenario (sections III.A through III.E), in terms of detection, computation and communication. We later refer to load in a more generalized term of *responsibility*. After analyzing the relationship between *responsibility* and network elements, we define a utility function which if maximized implies a network-wide gain in throughput and other performance metrics.

Responsibility Matrix							Detection	Computation	Communication
	SN _L	MR _L	GW _L	SN _F	MR _F	GW _F			
A	•	×	×	×	×	×			
B	•	×	×	•	×	×			
C	×	•	×	×	•	×			
D	×	•	×	×	•	×			
E	•	×	×	×	×	×			

Figure 7: Coarse (non-optimized) usage of network elements

Fig. 7 shows the responsibility matrix in mobility scenarios A-E in which the connectivity is handled by the devices that are on the move themselves. The subscripts L and F refer to the local (departure network) and foreign (arrival network) elements. Here, we define the utility function U for a generalized device (SN: sensor node, Mobile Router: MR, and GW: Gateway) as the linear summation of the rewards and penalties. The rewards are associated to the device's resources and the penalties are associated to its distance from the destination in as per the ordered relationship SN>MR>GW (hierarchical connectivity follows the relationship SN>MR, SN>>GW, MR>SN, MR>GW, GW>MR, GW>>SN).

$$U = R + P$$

$$R = \begin{cases} x \times n & SN \\ ax & MR \\ bx & GW \end{cases}$$

$$P = \begin{cases} y & > \\ cy & >> \end{cases}$$

Note that the effective penalty in the case of sensor nodes would be $n \times P$ where n is the number of sensor nodes. A cautious calculation using table II to obtain the normalized values of the coefficients yields $a=1$, $b=175$ and $c=7754$, as the proportionate capabilities of devices. For table I with $x=1$ and $n=10$, the utility functions for the mobility scenarios are $U_A=10$, $U_B = 20$, $U_C = 350$, $U_D = 350$, $U_E = 10$.

Now that we have obtained a benchmark performance in terms of utility function, we present the architecture and the protocol that optimizes the handling of mobility under the scenarios purported above.

5. Proposed Scheme

In our proposed scheme we introduce a middleware (Mobile Ubiquitous Nodes, Negotiation Agent (MUNNA)) with the sensor gateway to support mobility functionality on behalf of the MN. It helps to share the responsibility by migrating the load of smaller devices (both low- and medium-end) to bigger network elements such as the GW and the MR [15]. Figure 8 depicts the general overview of the proposed scheme along with the possible mobility scenarios.

5.1 Handoff in different Scenarios:

Before going with the operation details, let's examine the handoff details for the different mobility scenario, which makes our protocol as the ubiquitous solution.

Scenario 'A': Intra-PAN node mobility is unaware of MUNNA; it will be handled by 2nd layer mobility feature for the specific protocol.

Scenario 'B': Inter-PAN node mobility requires the support of MUNNA. If the PAN node moves alone from one network to other network, 2nd layer mobility detection mechanism will recognize the mobility happened and will be triggered with the route solicitation message, after that it will follow the protocol description.

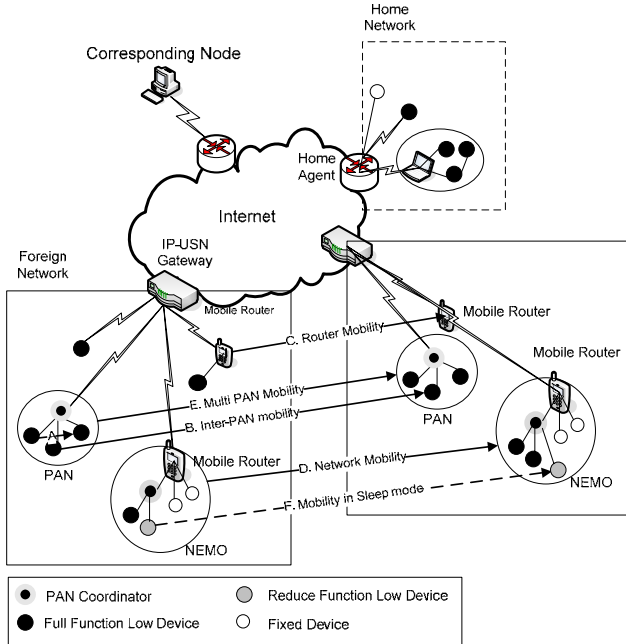

Figure 8: Basic Architecture & Different Handoff

Scenario 'C': In Router mobility the associated node become orphan, those nodes can be associated with the near mobile router or access network. Those nodes will trigger like they arrived in a new foreign network.

Scenario 'D': In Network mobility scenario, the associated network node will be unaware of the mobility and MUNNA will rearrange the table according as he got all the information about the associated nodes. If any visiting nodes come to join this mobile network, it will be associated as single low capable device like Inter PAN association.

Scenario 'E': In Multi-PAN or group mobility, each node of the group will be triggered as individual node. The shorting mechanism in the delegation table will make sure that those individual nodes for the same purpose will get supported together with the single signal.

Scenario 'F': In the special case of sleep mode, each node always is aware of their 2nd layer association. So, when it will change its local link point of attachment, it will be in full function mode and execute the mobility handoff. When it will be in sleep mode the MUNNA will also be aware of it, so it will reduce the extra signaling which is not important for the sleep mode devices.

5.2 LowMIPv6 Operation

5.2.1 Mobile Node in Home Agent

At Home, Low capable Mobile Nodes will register its home address by specifying as a low capable device. Thus, the home agent (HA) maintains its identity for the mobility support with some initial secretes for authentication purpose.

Table 1: Delegation Table

Home Address	HA Address	CN Address	Life Time	Status	Flags
3ffe:200:8:1:	3ffe:210:8:1	3afe:210:8:1	15	Act	A/H/
5ffe:210:8:1	3ffe:220:E:1	3bfe:202:8:1	20	Sleep	A/K

5.2.2 Mobile Node in foreign Network

Initial Association and Delegation: 1. While LowMN moves into the foreign network, it detects the change of its networking using the prefix advertisement. LowMN will response with the Router Solicitation Message with HA (RSMHA), which will help the access router to distinguish the LowMN from the other usual mobile node of MIPv6 capability. In that consequence, the access router forwards the device activity to the MUNNA for further mobility association and delegation activities.

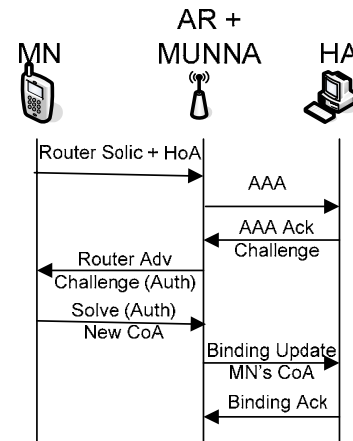

Figure 9: LowMIPv6 Handover Process

2. When MUNNA gets the LowMN, it updates the nodes care-of-address and home address in the delegation table (fields shown in the table 1), Table in the sorted order with the home address. The care-off-address is generated by auto-configuration with it source MAC address and home address prefix.

3. After that, MUNNA sends Network and node Authentication message (N2AM), to the home agent for the authentication of itself to support the delegation on behalf of the LowMN and at the same time authenticate the node itself.

4. When home agent get the N2MA, its checks authentication for the LowMN and response with a Challenge Message (CM) to solve using the initial secretes at the time of registration.

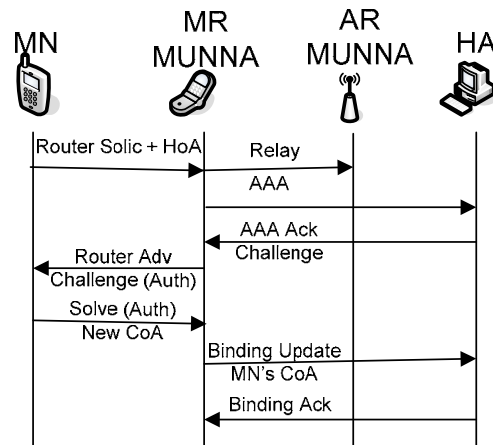

Figure 10: LowMIPv6 Handover (MR)

5. As soon as MUNNA gets the CM from the home agent it sends the router advertisement with the Challenge to be solve. In

that case the challenge format is put into the option bits of the router advertisement message.

6. After getting the RA LowMN auto-configure its care-of-address and also solve the problem with some simple function and acknowledge with the solution.

8. When MUNNA gets the solution, it makes the Binding Update (BU) message with solution and sends it to the Home agent. Home agent authenticates LowMN and MUNNA using the correct solution and registers the current MUNNA and the LowMN care-of-address (CoA). After that it acknowledges the MUNNA and MUNNA acknowledge the LowMN. After that the MUNNA gets the control over the LowMN further operations.

5.2.3 Route Optimization

1. LowMN sends the CN initiation message with current CN list to start the data transfer.

2. MUNNA updates its CN list in delegation table and wait for a random time with probability analysis of the group mobility. If more than one node is moving for the same purpose, it will have the same home agent and same corresponding nodes. And it has more probability that low capable devices with move together as a group or as the form of a PAN. Thus PAN's nodes have the more probability to be from the same home agent and working with the same corresponding nodes.

3. After a random time, MUNNA get the nodes with same corresponding node and home agent. MUNNA will perform the return routability test for the corresponding nodes. Actually it make this process will be aggregated for the common nodes and work at the same time.

4. After the Return routability test, MUNNA will acknowledge the individual node.

5.2.4 Sleep state association

1. When Mobile Node change its state to the Sleep state or off state, its send the status change message to the MN.

2. MUNNA incorporates this message with the delegation table. When binding life it will be finished and need to send binding refreshment message for the HA and CN, MUNNA will take action according.

6. Analytical Model

To analyze the performance we define the simple analytical model. We compare our framework with MIPv6, HMIPv6, NEMO & PMIPv6 [7][8]. We determine the overall mobility latency, overall energy consumption cost needed for MN and responsibility migration cost based on different scenarios.

6.1 MIPv6 Overall Mobility latency Analysis:

MIPv6 mobility cost includes the overall location update latency and total binding refreshment cost, which can be determine using the following simple deterministic methods [9][10][11][12].

6.1.1 Location Update Cost

Location update cost involves the binding update cost for Home Agent (HA) and binding update cost for the Corresponding node (CN).

6.1.2 Binding update latency for HA

Binding update cost for Home Agent includes [12] the, Movement Detection Delay " τ_d ": This is the time required by the MN to detect the Mobility. IP CoA configuration Time " τ_c ": Time to configure the Care of Address. Binding registration time " τ_b ":

Table 2: Meaning of Symbols and Notation

Symbol	Meaning of the Symbols	Typical Values
l_{dh}	Average Number of hopes between AR to HA.	15
l_{dc}	Average Number of hopes between AR to CN.	10
l_{mn}	Average Number of hopes between AR to MAP/LMA	4
α_{BU}	Per hope transmission delay cost wired.	5ms
γ_{BU}	Per hope transmission delay cost wireless.	10ms
ω	Proportionality constant of signaling for wireless	5ms
t_{sub}	Mobile Nodes subnet Resident time.	100 sec
RTT	Router Transmission Time	*
T	Transmission time	*
BU_{MIP}	Average binding update cost by MIPv6.	**
ϵ	Average number of the CNs when an MN moves into/out of a given domain	5
τ_d	Time required for mobility detection (2 nd layer handoff)	**
τ_c	Time to configure the Care of Address.	**
τ_b	Time Need for the binding update in the home Agent.	**
ρ_{tx}	Energy required for transmitting packet	**
ρ_{rx}	Energy required for receiving packet	**
μ_{BU}	Per hope Energy cost for the wireless link	10
σ	Proportionality constant of signaling energy cost.	0.6
E_d	Energy required for mobility detection.	**
E_a	Energy required for Care-of-Address Association	**
E_b	Energy required for binding registration	**
E_{BHA}	Energy required for Binding update association with Home Agent	**
E_{BCA}	Energy required for Binding update association with Corresponding Node	**
E_{BRef}	Energy cost for the binding-Refreshment	**

*those values depend on the other parameter, which we have taken the typical value for our simulation.

** Its will give the total values.

Time Need for the binding update in the home Agent. If we consider the total handoff latency for the binding update in home agent can represent by (BU_{UH}), which is the sum of the first 3 aforementioned latency component. $BU_{UH} = \tau_d + \tau_c + \tau_b$
Movement Detection is sum of two individual components: Link switching delay, τ_{da} : This is the time delay pertaining to the re-association. Link local IPv6 configuration delay, τ_{dl} : This is the time between the first time that the MN encounters a new link by receiving neighbor advertisement. Thus the movement detection time is, $\tau_d = \tau_{ls} + \tau_{ld}$

IPv6 CoA Configuration Delay: We define the CoA configuration time (τ_c) as the time commencing from the moment of the receipt of a route advertisement to the moment that Duplicate Address Detection (DAD) and the update of the routing table has completed. For the stateless IPv6 address auto-configuration (τ_a) is comprised of the following delay components:

$$\tau_c = \tau_{RteAdv} + \tau_{RteSoli} + \tau_{AddConfig} + \tau_{DAD} + \tau_{routeUpdate}$$

$$\tau_c = 4 * \omega * \gamma_{BU} + \tau_{AddConfig} + \tau_{routeUpdate}$$

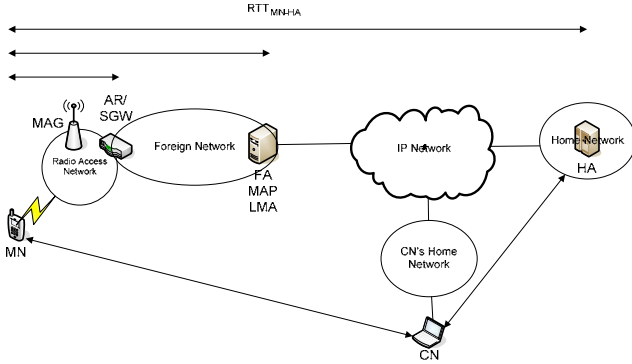

Figure 11: Analytical Model

Binding Registration Time: The Binding registration time (τ_b) is defined as the transmission delay incurred during registration of the MN CoA with its HA.

$$\tau_b = RTT_{MN-HA} + BU_{Proc} + BA_{Proc}$$

$$\tau_b = \{2 * (l_{dh} - 1) * \alpha_{BU}\} + 2 * \omega * \gamma_{BU} + BU_{Proc} + BA_{Proc}$$

Binding update latency for the CN:

The route optimization time " τ_r " is defined as the transmission delay incurred during registration of the MN bindings with the CN that is furthest away in two distinct cases depending on the mode of security affected in the BU registration process:

$$\tau_r = T_{HOT-COT} + (RTT_{MN-CN} + BU_{Proc} + BA_{Proc})$$

$$\tau_r = \{4 * (l_{dh} - 1) * \alpha_{BU}\} + 4 * \omega * \gamma_{BU} + \{2 * (l_{dh} - 1) * \alpha_{BU}\} + 2 * \omega * \gamma_{BU} + BU_{Proc} + BA_{Proc}$$

$$\tau_r = \{6 * (l_{dh} - 1) * \alpha_{BU}\} + 6 * \omega * \gamma_{BU} + BU_{Proc} + BA_{Proc}$$

Thus we can say the Binding update cost of the corresponding nodes can be represented by (τ_{UC}), which is equal to the Route optimization cost. Thus+

$$BU_{UC} = \tau_r = \{6 * (l_{dh} - 1) * \alpha_{BU}\} + 6 * \omega * \gamma_{BU} + BU_{Proc} + BA_{Proc}$$

Thus the Overall Location update latency for MIPv6:

According to our mobility model given in the last section the average binding update cost can be derived as (We use the fluid flow mobility model, probability of, $\pi_0 = \frac{1}{2}$).

$$BU_{MIP} = \pi_0 * (BU_{UB} + \varepsilon * BU_{UC})$$

5.1.2. Binding Refreshment Cost

Let the binding lifetime for the HA and CN in MIPv6 be $\tilde{\tau}_h$ and $\tilde{\tau}_c$ respectively. Then the average binding refresh cost in MIPv6 can be derived as follows:

$$R_{MIP} = \left(BU_{UB} * \left[\frac{t_{sub}}{\tilde{\tau}_h} \right] + \delta * BU_{UC} * \left[\frac{t_{sub}}{\tilde{\tau}_c} \right] \right)$$

Here, δ is the ratio of an MN's average binding time for the CNs to its average domain residence time.

Table 3: BU Latency Analysis

Type	Binding Upate for HA	Binding Upate for CN
HMIPv6 Inter	$\tau_d + \tau_c + \{2 * (l_{dh} - 1) * \alpha_{BU}\} + \{2 * (l_{mn} - 1) * \alpha_{BU}\} + 2 * \omega * \gamma_{BU} + BU_{Proc} + BA_{Proc}$	$\{6 * (l_{dh} - 1) * \alpha_{BU}\} + 6 * \omega * \gamma_{BU} + BU_{Proc} + BA_{Proc}$
HMIPv6 Intra	$\tau_d + \tau_c + \{2 * (l_{mn} - 1) * \alpha_{BU}\} + 2 * \omega * \gamma_{BU} + BU_{Proc} + BA_{Proc}$	$\{6 * (l_{dh} - 1) * \alpha_{BU}\} + 6 * \omega * \gamma_{BU} + BU_{Proc} + BA_{Proc}$
NEMO	0	$T_{HOT-COT_{MR-CN}} + (RTT_{MR-CN} + RTT_{MN-MR} + BU_{Proc})$
PMIPv6	$\tau_d + \tau_c$	$T_{HOT-COT_{MAG-CN}} + (RTT_{MAG-CN} + RTT_{MN-MAG} + BU_{Proc})$
LowMIPv6	$\tau_d + \tau_c + 2 * RTT_{MN-MUNNA} - \tau_{prefAdv} + 2 * RTT_{MUNNA-HA} + BU_{Proc} + BA_{Proc} + MUNNA_{Proc} + \text{ChallengGenerat}_{Proc} + \text{ChallengSolve}_{Proc}$	$T_{HOT-COT_{MUNNA-CN}} + (RTT_{MUNNA-CN} + RTT_{MN-MUNNA} + BU_{Proc} + BA_{Proc} + MUNNA_{Proc})$

$\delta = \frac{\sum_{i=1}^n C_i}{\Delta}$. Where Δ means an MN's average domain residence time, and C_i represents the binding time for the i-th CN, which has been recorded in an MN's binding update list during its average domain residence time. Also, n means the number of all the CNs recorded in the MN's binding update list during its average domain residence time.

Thus

$$R_{MIP} = \left(BU_{UB} * \left[\frac{t_{sub}}{\tilde{\tau}_h} \right] + \left(\frac{\sum_{i=1}^n C_i}{\Delta} \right) * BU_{UC} * \left[\frac{t_{sub}}{\tilde{\tau}_c} \right] \right)$$

Thus the Total singling cost of MIPv6 is the sum of the total handoff cost and total binding refreshment cost.

$$Total_{MIP} = BU_{MIP} + R_{MIP}$$

We follow the same analytical model as MIPv6, and the above table, shows the Binding update cost to update with HA or MAP and with CN for route optimization.

If we consider the group update the binding update latency for CN,

$$\overline{B_{CA}} = \left(\frac{\{6 * (l_{dh} - 1) * \alpha_{BU}\}}{\partial_{CU}} \right) + 2 * \omega * \gamma_{BU} + BU_{Proc} \\ + BA_{Proc} + MUNNA_{Proc} \\ + Random Dealy$$

Where, ∂_{CU} is the number node are in group.

6.2 MIPv6 Energy Cost

In this section we analyzed the energy consumption by the individual node while maintaining mobility. The minimum energy need for one mobile node to transmit $\rho_{tx} = \rho_{rx} = \frac{2WN_0\beta}{(r/a_0)^{-\eta}}$, Where,

β is the minimum SNR, η is the path loss r is the transmission range, W pulse bandwidth, N Gaussian variance. In our evaluation we have taken the general values for those parameters [13][14].

MIPv6 Mobile Nodes Total Power consumption for Mobility Scenario: The power consumption will be the sum of energy required for the movement detection, care-of-address association and binding registration energy cost. Thus,

$$E_{B_{HA}} = E_d + E_a + E_b$$

$$E_{B_{HA}} = 2 * \rho_{tx} + 2 * \rho_{rx}$$

$$E_{B_{CA}} = 3 * \rho_{tx} + 3 * \rho_{rx}$$

Total Energy cost on MN for the MIPv6 handoff, $E_{U_{MIPv6}} = \pi_0 * (E_{B_{HA}} + \varepsilon * E_{B_{CA}})$

Total Energy cost on MN for the MIPv6 Binding Refreshment $E_{R_{MIP}} = (E_{\tau_{UH}} * \left[\frac{t_{sub}}{\tau_h} \right] + \delta * \vartheta * E_{\tau_{UC}} * \left[\frac{t_{sub}}{\tau_c} \right])$,

Where, ϑ is the probability co-efficient when in power saving mode. ($0 < \vartheta < 1$)

Total Energy cost in the Process of mobility, $E_{Total_{MIP}} = E_{U_{MIP}} + E_{R_{MIP}}$

Table 4: Energy Cost Analysis

Type	Energy for BU (HA)	Energy for BU (CN)
HMIPv6 Inter	$2 * \rho_{tx} + 2 * \rho_{rx}$	$4 * \rho_{tx} + 4 * \rho_{rx}$
NEMO (Initialization)	$\rho_{tx} + \rho_{rx}$	0
PMIPv6	$\rho_{tx} + \rho_{rx}$	0
LowMIPv6	$2 * \rho_{tx} + \rho_{rx}$	0

7. Numerical Result

We redefine the responsibility matrix for MIPv6, HMIPv6, NEMO, PMIPv6 and LowMIPv6, to analyze the performance

Responsibility Matrix							Detection	Computation	Communication
	SN _L	MR _L	GW _L	SN _F	MR _F	GW _F			
A	•	×	×	×	×	×			
B	•	•	×	•	×	•			
C	•	•	×	×	•	•			
D	•	•	×	×	•	×			
E	•	•	×	×	×	•			

Figure 13: Migration Table for LowMIPv6

based on different scenario.

Evaluation 1:

Individual scenario performance based on responsibility migration: In the case of LowMIPv6, most of the work load is shifted in the gateway. Most of the mobility scenario we can migrate the responsibility which suggest that we can save work load on the particular sensor node.

According to our current responsibility matrix we can redefine our utility function with the same value of $x = 1$ and number of nodes 10. We can have $U_A = 10$, $U_B = 31211$, $U_C = 31376$, $U_D = 360$, $U_E = 31111$. It's apparently suggesting that we have increased the utility of the network elements by sharing the responsibility through migration.

Similarly refined MIPv6, HMIPv6, NEMO & PMIPv6 yields the following figures.

Table 5: Responsibility Redefine

	MIPv6	HMIPv6	NEMO	PMIPv6	LowMIPv6
U_A	10	10	N/S	10	10
U_B	20	20	N/S	15508	31211
U_C	N/S	N/S	N/S	N/S	31376
U_D	N/S	N/S	350	N/S	360
U_E	N/S	N/S	N/S	31111	31111

*N/S – Not Supported

Evaluation 2:

To calculate the disrupt time, we used the typical value used in the table2, also we took some typical values from [11][12][13], we get the following results:

Table 6: Handoff Delay

	MIPv6	HMIPv6 6 (Intra)	HMIPv6 6 (Intra)	NE- Mo	Ptoxy MIPv6	Low MIPv6
Delay in Sec	1.37	0.34	1.63	0	0.31	0.41

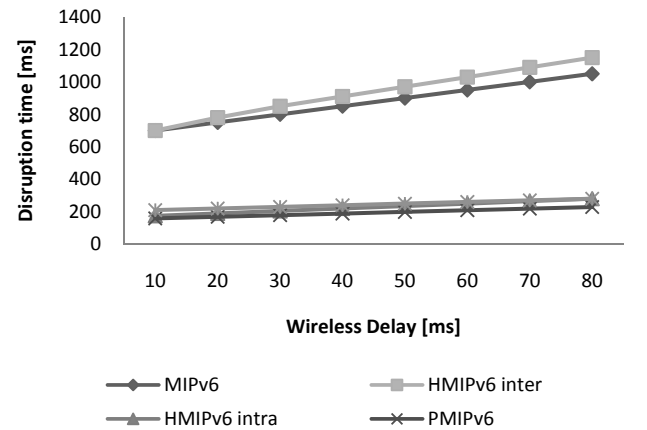

Figure 12: Disruption time versus wireless link delay

Impact of the Handoff Delay for HA: The result in table 6 shows that the delay to update location to the HA or MAP. It shows that NEMO performing the best. While LowMIPv6 performing compromise better if we consider, it requires minimal change in the architecture and supporting all scenarios.

Evaluation 3:

Impact of the Wireless Link Delay: The results obtained with varying wireless link delay give more insight to the comparisons. Indeed, Fig. 13 shows that the wireless link delay increase affects the handoff delay for all the protocols analyzed. This also shows that NEMO perform best, but only support one kind of mobility scenarios.

Evaluation 4:

Impact of the Energy consumption by MN: The results obtained with varying the average number of the CNs when an MN moves into/out of a given domain with the energy consume in micro-joule in figure 14.

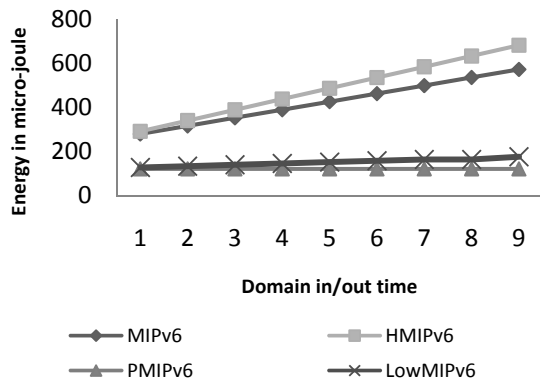

Figure 14: CN change versus energy consumption

8. Conclusion

In our architecture, we have provided the light weight MIPv6 technique based on network based mobility with minimal change in host based mobility. Also we have focused on all possible mobility scenarios for the sensor node and try to evaluate the system based on all mobility scenario models. Our scheme has the capability to handle the basic all kind of mobility scenario for low capable sensor devices, also it provides the light weight authentication mechanism for those Low capable devices. We have evaluated our scheme with the responsibility matrix and analytical model. Our scheme shows a valiant effort to make a ubiquitous mobility solution considering the energy and efficiency. To give a full extension of our work, we are implementing out protocol in IPv6 enable IEEE 802.15.4 devices.

9. ACKNOWLEDGMENTS

This work was supported by the IT R&D program of MKE/IITA (Development of IP-based Sensor Network(IP-USN) technology) and by the Agency for Defense Development (ADD), Korea.

10. REFERENCES

- [1] G. Montenegro, "Transmission of IPv6 Packets over IEEE 802.15.4 Networks", IETF RFC 4944, Sep 2007.
- [2] D. Johnson. IP Mobility Support, IETF RFC 3775, June 2004.

- [3] V. Devarapalli, "Network Mobility (NEMO) Basic Support Protocol", IETF RFC 3963, Jan 2005.
- [4] H. Soliman, "Hierarchical Mobile IPv6 Mobility Management (HMIPv6)", IETF RFC 4140, Aug 2005.
- [5] P. McCann, "Mobile IPv6 Fast Handovers for 802.11 Networks", IETF RFC 4260, Nov 2005.
- [6] J. Kempf, Problem Statement for Network- Based Localized Mobility Management (NETLMM), IETF RFC 4830, Apr 2007.
- [7] Debashis Saha, Amitava Mukherjee, Iti Saha Misra, Mohuya Chakraborty, "Mobility Support in IP: A Survey of Related Protocols", IEEE Network • November/December 2004.
- [8] Henrik Petander, Eranga Perera, Kun-chan Lan, and Aruna Seneviratne., "Measuring and improving the performance of network mobility management in IPv6 networks", IEEE journal on selected areas in communications, vol. 24, no. 9, september 2006.
- [9] Abu S Reaz, Pulak K Chowdhury, Mohammed Atiquzzaman, William Ivancic, "Signalling Cost Analysis of SINEMO: Seamless EndtoEnd Network Mobility"
- [10] Hyung-Jin LIM, Dong-Young Lee, Tae-Kyung KIM, Tai-Myoung Chung, " A Model and Evaluation of Route Optimization in Nested NEMO environment".
- [11] Ki-Sik KONG†a), MoonBae SONG†, KwangJin PARK†, and Chong-Sun HWANG, "A Comparative Analysis on the Signaling Load of Mobile IPv6 and Hierarchical Mobile IPv6: Analytical Approach*", IEICE TRANS. INF. & SYST., VOL.E89-D, NO.1 JANUARY 2006.
- [12] Abu S Reaz, Pulak K Chowdhury, Mohammed Atiquzzaman, William Ivancic, "Signalling Cost Analysis of SINEMO: Seamless EndtoEnd Network Mobility", IEEE Conference.
- [13] Anurag Kumar, D. Manjunath, Joy Kuri, "Communication Networking: An analytical Approach". Chap 8, Page 457.
- [14] Sun-Jong Kwon, Seung Yeob Nam, Ho Young Hwang, and Dan Keun Sung, "Analysis of a Mobility Management Scheme Considering Battery Power Conservation in IP-Based Mobile Networks", IEEE TRANSACTIONS ON VEHICULAR TECHNOLOGY, VOL. 53, NO. 6, NOVEMBER 2004.
- [15] Robert C. Chalmers and Kevin C. Almeroth, "A Mobility Gateway for Small-Device Networks", Percom 2006.
- [16] U. J onsson, F. Alriksson, T. Larsson, P. Johansson, and G. Maguire. MIPMANET - mobile IP for mobile adhoc networks. In Proceedings of Workshop on Mobile Ad Hoc Networking (MobiHOC'00), Boston, MA, USA, Aug. 2000.
- [17] Hanane Fathi, Shyam S. Chakraborty Ramjee Prasad, "Optimization of Mobile IPv6-Based Handovers to Support VoIP Services in Wireless Heterogeneous Networks", January 2007, IEEE Transaction on Vehicular Technology.