

Effect of the Addition of Ferric Nitrate on Electrochemical Machining of 304 Stainless Steel in Sodium Nitrate Solution

Sri Hastuty¹, Diah Chori Pertiwi², Byan Wahyu Riyandwita³, Muhammad Akbar Barrinaya⁴, Judha Purbolaksono⁵, Suharti, Yose Fachmi Buys⁶, Muhammad Awwaluddin⁷

{sri.hastuty@universitaspertamina¹}

Department of Mechanical Engineering, Universitas Pertamina, Jakarta, Indonesia¹

Abstract. Research on static electrochemical machining processes carried out on Stainless steel 304 or AISI 304 specimens to determine the optimum combination of parameters to produce surface roughness with a high MRR value or feed rate. Static electrochemical machining research does not involve the presence of flow by combining various parameters to produce the desired goal. This study's voltages are 10, 15, 20, and 25V, with temperatures of 25, 40, and 50 OC. The time used is 1 minute, and using the test solution, NaNO₃ added Ferric Nitrate in the content of 1%, 3%, and 5%. The selected test place uses acrylic material and is connected with a cable connected to the DC Power Supply. Then, the finished test object is taken macro images to see the surface of the test object. After that, microscopy was carried out using an optical microscope to determine the topography of the test so that the results obtained on the test object showed that there had been intergranular corrosion on the surface and got good test object surface results.

Keywords: ECM, Surface Roughness, MRR, Stress, Temperature, Solution

1 Introduction

Stainless steel is a material used in various industries. For example, stainless steel 304 is generally used in the transportation, architecture, food appliance, chemical, and power engineering industries [1]. Generally, the materials used in transportation must have good machinability and corrosion resistance. Examples of components used in the transportation industry are micro-sized bearings and macro-sized piston heads. Until now, micro-scale products are needed in various industries, especially in the transportation industry, with component product specifications with flat and smooth surface roughness [2].

Judging from the need for product specifications that have a smooth and even surface roughness, conventional machining is not sufficient to meet the product specifications. It happens because of the limited shape of the tool blades used in conventional machines [3]. In addition, the hardness of the material used is high enough to exceed the strength of conventional machine tools such as milling and lathe machining [3]. With the shortcomings in conventional machining, non-conventional machining becomes another alternative to meet product needs. Non-conventional machining has the function of machining on a micro scale with complex shapes and feeding the surface of the workpiece relatively quickly, and the level of smoothness is quite high [4]. Therefore, electrochemical machining was chosen by utilizing a dc power supply and electrolyte solution in the machining process. In the electrochemical machining process, many parameters are used to produce optimal results, such as electrolytic fluid,

molarity, voltage, temperature, and time. Thus, from these parameters emerge deficiencies in electrochemical machining [4]. However, these shortcomings can be controlled by a combination of parameters carried out in the study.

S.Ayyappan, K. Sivakumar, and M.Kalaimathi conducted a study about a combination of parameters carried out with a voltage of 0.3 V to 0.9 V within 20 minutes, so the feed results were obtained with an average of 0.3 mm/min. The mixing of ferric nitrate and NaCl has a fairly good surface structure. It can be concluded that the ECM process with ferric nitrate mixed with NaCl produces a good parameter test [6].

In addition, research conducted by Zohoor, Alipour, and Mossalanejad using NaCl, KCL, and NaNO₃ resulted in the effect of the type of electrolyte on material feeding, side gap, and surface roughness in stainless steel 304, which is relatively high [7].

The research conducted by Fattah Nur Rahman is the optimization of electrochemical machining process parameters on stainless steel AISI 304. This study compares the types of electrolytes used with NaCl and NaNO₃. So we get the results that the type of NaNO₃ solution has a smoother surface roughness level compared to NaCl. However, the shortcoming of this research is that the type of electrolyte used still produces an inconsistency in the current density that affects the surface feeding rate of the AISI 304 specimen. [8]

Thus, our research focuses on the electrochemical machining process that combines the type of solution, stress, and temperature on AISI 304 stainless steel material which aims to get the optimal combination of parameters with high feed rates with smooth surface roughness.

2 Material and Method

2.1 Sample Preparation

The preparation stage includes purchasing ferric nitrate electrolyte solution and cutting type 304 stainless steel plate. Preparation of NaNO₃ electrolyte solution is mixed with 1%, 3%, and 5% ferric nitrate solution of NaNO₃ solution. After that, cut the plate with a size of 2 cm x 2 cm using a grinder cutting tool and sand the workpiece cut on the cutting part and the surface to be tested. Sanding was carried out at grades 240, 400, 600, 800, and 1000 CW. Then, the rotation on the polishing machine is set at 100 rpm by changing the sanding direction to 90 each time the sandpaper is changed.

At the electrochemical machining testing stage at electrolyte temperatures of 25, 40, and 50°C, temperature changes are caused by being heated in a glass beaker using an electric stove, and every increase in temperature is observed through a thermometer. Electrolyte solution using NaNO₃ mixed with ferric nitrate with a concentration of 1M. Then, the voltage changes in each experiment amounted to 5 times at 10, 15, 20, and 25V. The electrochemical machining test uses a rectangular acrylic object at the bottom, with each corner locked. Then, the workpiece is placed between the surface of the machining tool, and at the top is given a barrier (O-ring) circle (O-ring) for the liquid electrolyte that falls on the surface of the workpiece made of Teflon material. The cable is connected to a dc power source. Each pole must not be interchanged at the time of connection of the circuit. The negative pole will be connected to the gold cathode, and the positive pole will be connected to the type 304 stainless steel anode. After that, the

electrolyte is poured and given 1 minute when the voltage has been adjusted according to the study. However, the 40 °C and 50 °C tests only reached a voltage of 20 V due to limitations on the cathode used. The cathode used is a gold ring thickened with copper and anodic elements if the temperature is 40 °C and 50 °C with a voltage above 20 V. Thus, it will cause new elements that are processed in electrochemistry, not only gold.

2.2 Characterization Technique

1. The current density calculation.

The current density is calculated every 10 seconds after the test starts using **equation (1)**. The current is recorded on the DC power supply after the required settings are made. It will be recorded and divided by the area on the surface of the workpiece exposed to the electrolyte solution.

$$J = \frac{I}{A} \quad (1)$$

Where: i = current, A = area, J = current density

2. The MRR calculation

The MRR calculation is done after getting the current density value for electrochemical machining using **equation (2)**. It is done to get the highest value from each electrochemical test.

$$MRR = \frac{m}{t\rho} = \frac{IA}{F\rho v} \quad (2)$$

Where ρ = density of the material, F = faraday constant, I = Amperes, A = atomic weight, V = electron valence.

3. Electrochemical Machining

The ECM concept has the basic principle of electrolysis so that the chemical process that occurs due to the conduction of electric current passes between two metals, and there will be a potential difference between the two metals. Thus, dissolving occurs in the metal or workpiece [6]. The dissolution that occurs at the anode using Faraday's first law with the number of elements dissolved in an electrochemical reaction will be proportional to the amount of electric charge used as represented on **equation (3)** [4].

$$m \cong Q \quad (3)$$

Then, Faraday's law also says that the amount of charge in the same electricity will have dissolved or precipitated or undissolved elements will be proportional to the equivalent weight of the substance used [4].

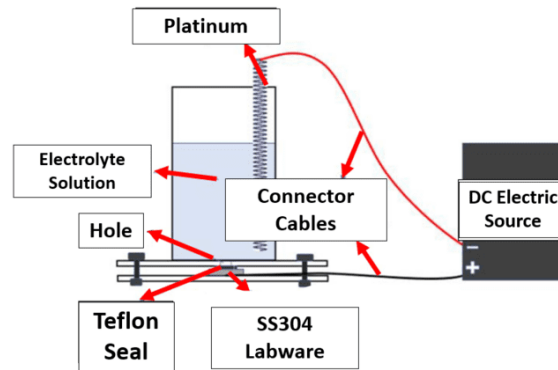

Fig. 1 Electrochemical Machining Schematic Diagram

In **Figure 1**, electrochemical machining uses a cathode of a gold ring and an anode of stainless steel 304, where sodium nitrate electrolyte liquid is added ferric nitrate with a composition of 1%, 3%, and 5%.

3 Result and Discussion

3.1 Current Density

Electrochemical machining produces results that can be known from the current generated each time the process runs. The description in the picture is black, indicating the voltage is 10 V, the green color is 15 V, the blue color is 20 V, and the red color is 25 V. The current seen on the DC power source is flowing when the electrochemical machining process is running.

It can be seen in **Figure 2** the relationship between current density and machining time. It shows current increasing from 0 to 10 seconds, at which time there is an initial anodic dissolution so that the dissolved metal from the workpiece and gas has been liberated in the cathodic device. It can be seen that when the line is black, the increase does not occur too much. It can be said to be constant. It is due to the passivation process carried out by stainless steel. Then there is a decrease when the machining process enters 20 seconds, and when it enters 30 seconds, it tends to be stable. NaNO_3 solution with a voltage of 25V and a temperature of 25°C showed a significant decrease in current at 50°C second time and rose to 60 seconds.

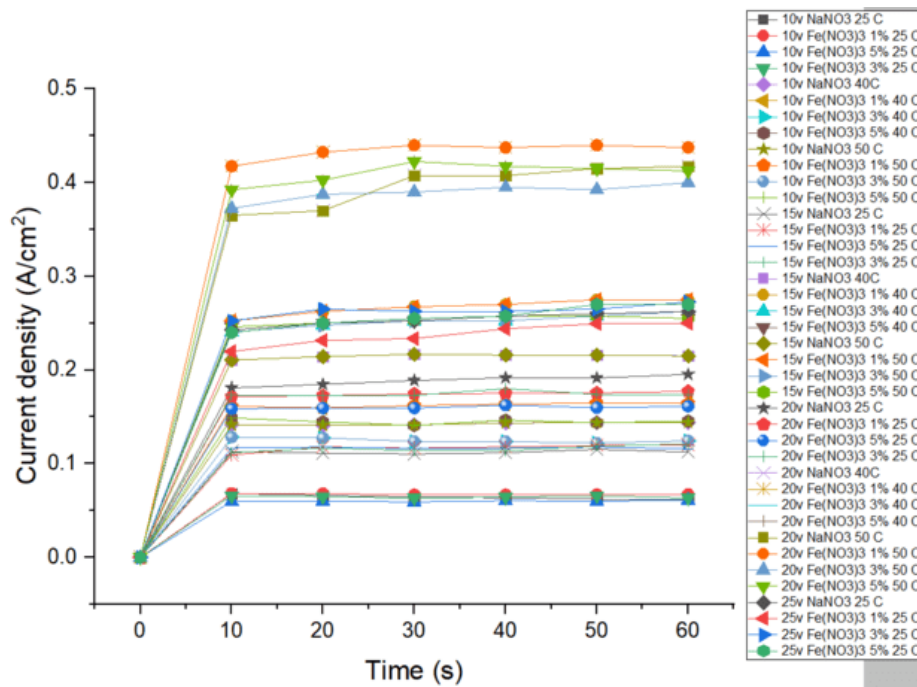

Fig. 2 Electrochemical Machining Current Density.

3.2 Material Removal Rate (MRR)

In **Figure 3**, the difference in the feed rate value for each experiment occurred due to the addition of ferric nitrate electrolyte liquid and the temperature changing from 25°C to 50°C. Ferric nitrate is an acid compound containing nitrate with a water quality value reaching a pH value of 6.2 so that it can damage the passive layer of the AISI 304 (<13.5) test object, which results in a higher feed rate [15]. Thus, when added to the composition of ferric nitrate, the resulting feed rate was higher than in the absence of the addition of ferric nitrate. The combination of parameters between types of electrolytes and temperature affects the difference in each specimen's feed rate.

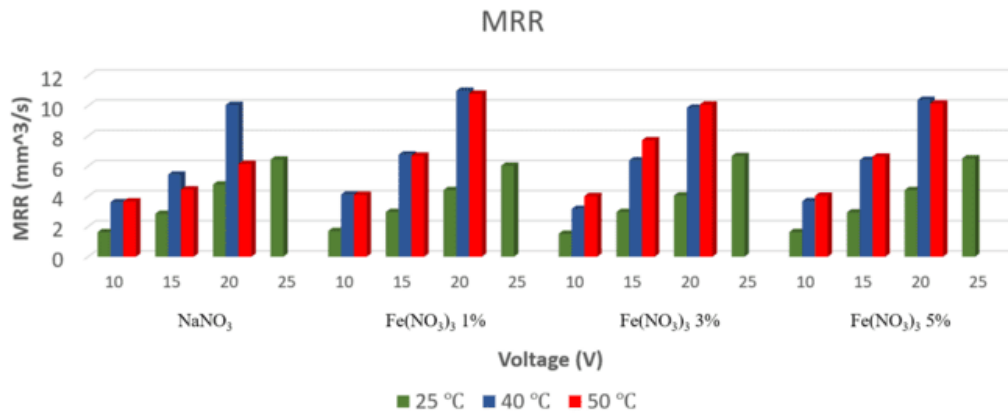

Fig. 3 Material Removal Rate

3.3 Macro Observation Results

With these calculations, it can be concluded that there is an increase and decrease in each electrochemical machining test for a one-minute duration with different voltage, temperature, and electrolyte parameters. It is also due to the electrical conductivity presence value for NaNO₃ of 85000 s/cm, which is not always in line with the increasing current density.

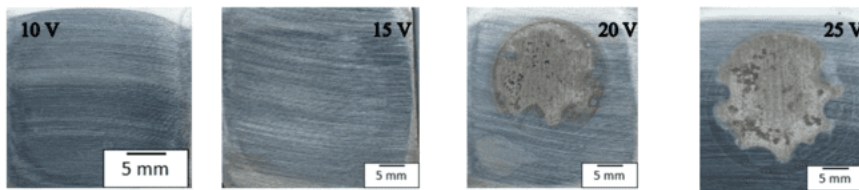

Fig. 4 Macro Images of 25 °C with NaNO₃ 1 M

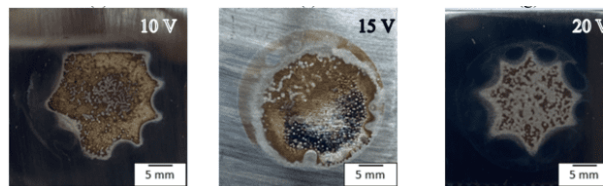

Fig. 5 Macro Images of 40 °C with NaNO₃ 1 M

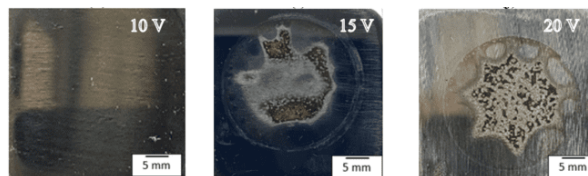

Fig. 6 Macro Images of 50 °C with NaNO₃ 1 M

Figure 4 Shows Macro Images of 304 Stainless Steel with treatment of 1M of NaNO₃ with 25°C and ranging voltage of 10V, 15V, 20V, and 25V. Figure 4 shows that at voltages of 10V and

15 V, there are no corrosion products at the surface area. **Figures 5 and 6** Show the Macro Image of 304 Stainless Steel with treatment of 1 M NaNO_3 with ranging voltage of 10V, 12V, and 25V and temperatures of 40°C and 50°C, respectively. **Figures 5 and 6** show that the increasing temperature made the corrosion product more significant, and the higher voltage made more corrosion products appear on the surface area.

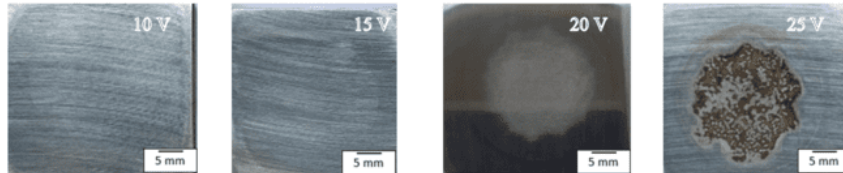

Fig. 7 Macro Images of 25 °C with $\text{NaNO}_3 + \text{Fe}(\text{NO}_3)_3$ 1% 1M

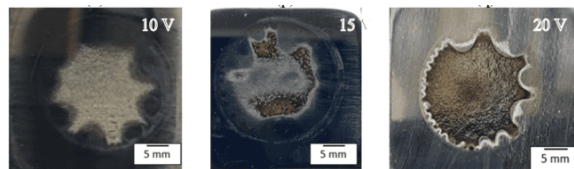

Fig. 8 Macro Images of 40 °C with $\text{NaNO}_3 + \text{Fe}(\text{NO}_3)_3$ 1% 1M

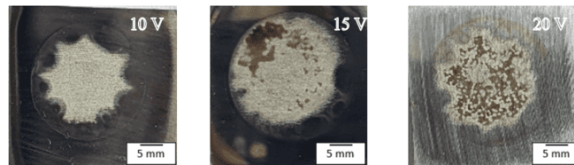

Fig. 9 Macro Images of 50 °C with $\text{NaNO}_3 + \text{Fe}(\text{NO}_3)_3$ 1% 1M

Figure 7 Shows Macro Images of 304 Stainless Steel with treatment of 1M of NaNO_3 added of 1% 1M $\text{Fe}(\text{NO}_3)_3$ with 25°C and ranging voltage of 10V, 15V, 20V, and 25V. **Figure 7** shows that by adding 1% of 1M $\text{Fe}(\text{NO}_3)_3$ to the solution at the voltage of 10V and 15 V, there is still no corrosion product on the surface area. **Figures 8 and 9** Show Macro Images of 304 Stainless Steel with the treatment of 1M of NaNO_3 added of 1% 1M $\text{Fe}(\text{NO}_3)_3$ and ranging voltage of 10V, 15V, and 20V with temperatures of 40°C, and 50°C, respectively. **Figures 8 and 9** show that the increasing temperature affected the surface area, where The corrosion product appeared at every voltage applied.

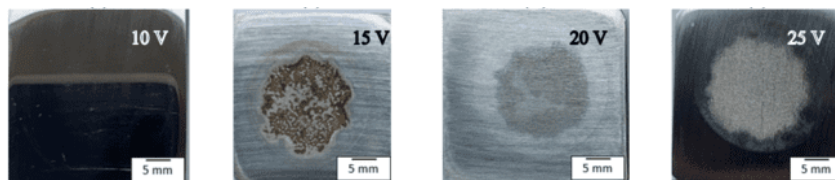

Fig. 10 Macro Images of 25 °C with $\text{NaNO}_3 + \text{Fe}(\text{NO}_3)_3$ 3% 1M

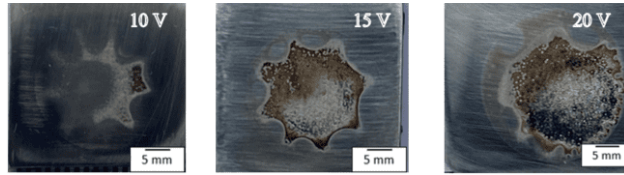

Fig. 11 Macro Images of 40 °C with NaNO₃ + Fe(NO₃)₃ 3% 1M

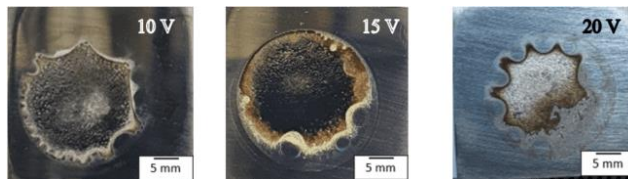

Fig. 12 Macro Images of 50 °C with NaNO₃ + Fe(NO₃)₃ 3% 1M

Figure 10 Shows Macro Images of 304 Stainless Steel with treatment of 1M of NaNO₃ added of 3% 1M Fe(NO₃)₃ with 25°C and ranging voltage of 10V, 15V, 20V, and 25V. **Figure 10** shows that adding 3% of 1M Fe(NO₃)₃ to the solution at 25°C made the corrosion product appear start from a voltage of 15V. **Figures 11 and 12** Show Macro Images of 304 Stainless Steel with treatment of 1M of NaNO₃ added of 3% 1M Fe(NO₃)₃ and ranging voltage of 10V, 15V, and 20V with temperatures of 40°C, and 50°C, respectively. **Figures 11 and 12** show that the increasing temperature made the corrosion product appear from the 10V potential applied and more corrosion product was observed at 50oC.

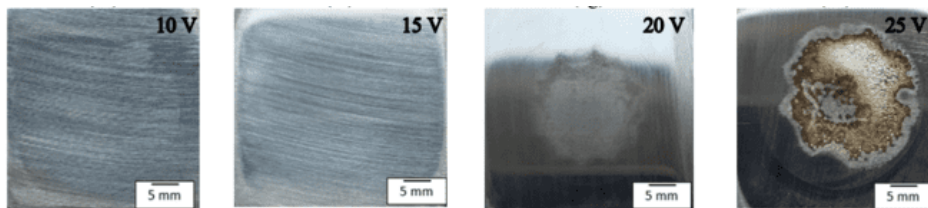

Fig. 13 Macro Images of 25 °C with NaNO₃ + Fe(NO₃)₃ 5% 1M

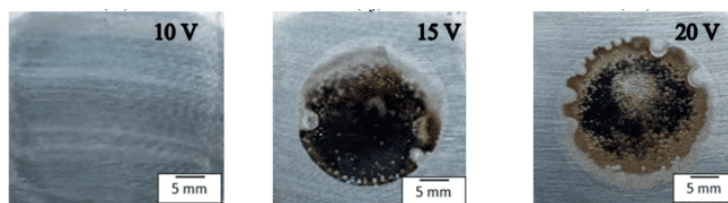

Fig. 14 Macro Images of 40 °C with NaNO₃ + Fe(NO₃)₃ 5% 1M

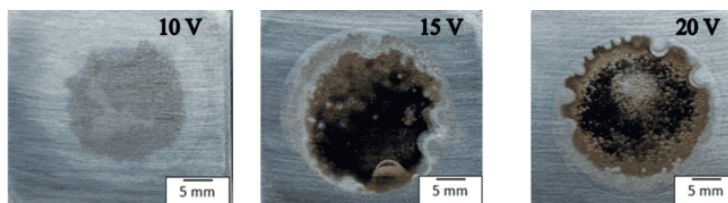

Fig. 15 Macro Images of 50 °C with NaNO₃ + Fe(NO₃)₃ 5% 1M

Figure 13 Shows Macro Images of 304 Stainless Steel with treatment of 1M of NaNO₃ added of 5% 1M Fe(NO₃)₃ with 25°C and ranging voltage of 10V, 15V, 20V, and 25V. **Figure 13** shows that adding 5% of 1M Fe(NO₃)₃ to NaNO₃ at 25°C made corrosion appear starting from 20V to 25V applied voltage. **Figures 14 and 15** Show Macro Images of 304 Stainless Steel with treatment of 1M of NaNO₃ added of 5% 1M Fe(NO₃)₃ and ranging voltage of 10V, 15V, and 20V with temperatures of 40°C, and 50°C, respectively. **Figures 14 and 15** show that at 40°C treatment, the corrosion product appears starting from 15V, but at 50°C treatment, the corrosion product appears starting from 10V. As **Figure 4-15** concludes, with the increase in temperature, the corrosion product appears more significant, which also corresponds with the voltage and solution.

For the addition of 1% ferric nitrate composition at a voltage of 10 to 15 V, a passivation process occurs in the test object where the surface of the test object has resistance to the corrosion process. Then, only corrosion occurs at 20 to 25 V. At a temperature of 50, a homogeneous surface occurs at a voltage of 10 V. Then, the addition of 3% ferric nitrate feeding on the surface begins to appear even though it does not look homogeneous. After adding 5% ferric nitrate, there was no significant change in the surface, given the 3% composition of the electrolyte solution. Ferric nitrate is an acid compound containing nitrate with a water quality value reaching a pH value of 6.2 so that it can damage the passive layer of the AISI 304 (<13.5) test object, which results in a higher feed rate [15]. Thus, when added to the composition of ferric nitrate, the resulting feed rate was higher than in the absence of the addition of ferric nitrate.

4 Conclusions

At current density, the result is that the higher the value of the applied voltage, it will affect the current density so that the flow of electrons that flows is also greater. It will increase the size of the reduced oxide layer so that the ingestion rate is also higher. The MRR value occurs due to the influence of the type of electrolyte fluid added with Fe³⁺ with a high value of +0.77 V, while the test object used is stainless steel AISI 304, which has a relatively low potential difference compared to the electrolyte fluid, which is -0.44 V; -1.66 V and -0.14V. So with a low potential value, the rate of dissolution and the process of being oxidized will be faster. This condition indicated by the resulting parameter is at 40 ferric nitrate 3% with a voltage of 20V. The combination of parameters resulting from the research, resulting in a homogeneous surface, is the combination of parameters 40°C Fe(NO₃)₃ 1% 20V and 25°C Fe(NO₃)₃ 3% 25V. In the static electrochemical machining research that has been carried out, the suggestions for further research validate the optimal combination of parameters in electrochemical machining.

References

- [1] A. International: Introduction to Stainless steels. Stainless steels, pp. 1-7 (2000)
- [2] T. Sathish: Stainless steels are used in a wide variety of machining parameters using electrochemical machining," Elsevier, vol. 5, pp. 1-10 (2019)
- [3] O. Adam: Pengaruh Variasi Jenis Media Pendingin Terhadap Surface Benda Kerja ST41 Dengan Menggunakan Uji Kekasaran (Surface Roughness Tester)," Institute Teknologi Balikpapan, p. 53 (2021)

- [4] T. Hidayat: Pengaruh Kedalaman Pemakanan, Jenis Pendingin dan Kecepatan Spindel terhadap Kekasaran Permukaan Benda Kerja pada Proses Bubut Konvensional. *Jurnal Teknik Mesin*, vol. 1, pp. 1-6 (2015)
- [5] S. M. A. B. Bhattacharyya: Electrochemical machining: new possibilities for micromachining," *Elsevier*, vol. 18, no. 3-4, pp. 1-10 (2002)
- [6] K. M. K. S. Ayyappan: Electrochemical machining of 20MnCr5 alloy steel with ferric nitrate mixed aqueous NaCl electrolyte," *Inderscience Enterprises*, vol. 17, pp. 1-16 (2015)
- [7] J. A. D. M. Zohoor: Effect of Electrolyte Type On Electrochemical Machining of 304 Steel," *International Journal of Advance in Engineering Research*, pp. 20-39 (2016)
- [8] F. Nurahman,,: Optimasi Parameter Proses Pemesinan Elektrokimia Pada Baja Tahan Karat AISI 304," *Universitas Pertamina*, pp. 1-61 (2020)
- [9] F. Hidayat: Studi Karakteristik Permesinan Material Baja St 60 Akibat Proses Annealing," *Universitas Hasanuddin, Makassar* (2021)
- [10] H. El-Hofy: *Fundamentals of Machining Processes*, New York: Taylor & Francis Group, LLC (2018)
- [11] R. A. B. P. R. Thanigaiavelana: Electrochemical micromachining of stainless steel with acidified sodium nitrate electrolyte. *Elsevier*, vol. 6, pp. 1-5 (2013)
- [12] F. Rokin: Pengaruh tegangan dan variasi jarak celah pada proses ECM menggunakan elektroda kuningan tidak terisolasi terhadap nilai MRR, overcut dan ketirusan pada aluminium 1100, *Jurnal Mesin UMY*, pp. 1-5 (2018)
- [13] S. Respati: *Macam-macam Mikroskop dan Cara Penggunaan*. Jurusan Teknik Mesin, Semarang, vol. 4, no. 2, pp. 42-44 (2008)
- [14] A. Jaedun,,: *Metodologi Penelitian Eksperimen*, Fakultas Teknik UNY, Yogyakarta, p. 5, (2011)
- [15] M. H. Hadi: Pengaruh current density terhadap kekerasan permukaan dan ketahanan korosi aluminium hasil pulse anodizing," *Universitas Brawijaya*, pp. 1-74 (2007)
- [16] S. Widanarko: The Effects of Corrosive Chemicals on Corrosion Rate of Steel Reinforcement Bars: II. Swamp Sludges. *Makara Jurnal Teknologi*, vol. 6, p. 68, 2002.
- [17] S. Nengsih: Perbandingan Kedalaman Pengikisan Logam," *Jurnal Ilmiah Pendidikan Teknik Elektro*, vol. 5, pp. 1-5 (2021)
- [18] S. A. B. B. Bhattacharyya: Robotics and Computer-Integrated Manufacturing, Electrochemical machining: new possibilities for micromachining, vol. 18, no. 3-4, p. 6 (2002)
- [19] A. Yafi: Pengaruh Kadar Kromium (Cr) Terhadap Kekerasan Dan Struktur Mikro Baja Paduan Fe-Cr-Mn Melalui Proses Peleburan, *Institut Teknologi Sepuluh Nopember*, pp. 5-3, (2016)