

Poster Abstract: Network Topologies for dual band (UWB – transmit and Narrow Band- receive) Wireless Body Area Network

K.M.Silva

The University of Newcastle
Callaghan, NSW, Australia,
2308.

kasunmaduranga.thotahewa
@uon.edu.au

M.R.Yuce

Monash University
Electrical and Computer
Systems Engineering
Clayton, VIC, Australia, 3800.
Mehmet.Yuce@monash.edu

J.Y.Khan

The University of Newcastle
Callaghan, NSW, Australia,
2308
Jamil.Khan@newcastle.ed
u.au

ABSTRACT

Ultra Wide Band (UWB) is an emerging technology in the application of Wireless Body Area Networks (WBAN). Its low power consumption, high band width and high data rate makes it a suitable candidate for transmission of vital physiological signals. Although UWB transmitter is of low power consumption, UWB receiver is complex in design and consumes much higher power than the transmitter. This limitation motivates us to look in to implementation of a mixed physical layer technology for WBAN sensor nodes using a UWB transmitter and a narrowband receiver.

Categories and Subject Descriptors

C.2.1 [Computer-Communication Networks] Network Architecture and Design- *Wireless communication*

General Terms

Design, Performance

Keywords

UWB, Narrow Band, WBAN, IEEE 802.15.4

1. INTRODUCTION

Medical telemetry for remote patient monitoring has grown in popularity in recent years. Wireless Body Area Networks (WBANs) provide patients with mobility which enables them to involve in their day to day activities while their vital body parameters are monitored in a remote location. Various wireless standards which are compared in Table 1 are being used for WBAN [1]. Ultra Wide Band (UWB) based technology stands out from other technologies due to the ability to produce high bandwidth at a lower transmission power. A task group (IEEE 804.15.6 TG6) [2] was formed in 2007 in order to develop a standard for the WBAN. In a WBAN, vital physiological parameters can be measured using several wearable and implantable sensors.

Permission to make digital or hard copies of all or part of this work for personal or classroom use is granted without fee provided that copies are not made or distributed for profit or commercial advantage and that copies bear this notice and the full citation on the first page. To copy otherwise, or republish, to post on servers or to redistribute to lists, requires prior specific permission and/or a fee.

BodyNets 2011, Beijing, China, 7–8 November 2011, ISBN (978-1-936968-29-9).

In this poster wearable sensors that contain two different communication links, UWB-transmit and narrowband-recvie, are considered for WBAN applications. The proposed WBAN network is based on three types of nodes as depicted in Figure 1. This enables the implementation of a WBAN in a large environment such as in hospitals, medical and care centers.

The main contribution of this work is three fold:

- A WBAN sensor design which uses UWB to transmit and Narrow band to receive is discussed with the attention given to inherent advantages of using Narrow Band in feedback path
- A pulse based UWB transmit system is discussed with the focus being given to dynamic transmit power allocation of the sensor node transmitter, depending on the receive signal strength at the receiver
- A priority driven MAC protocol is suggested for the use of this dual band system and its performance is compared over different network topologies and different data delivery scenarios

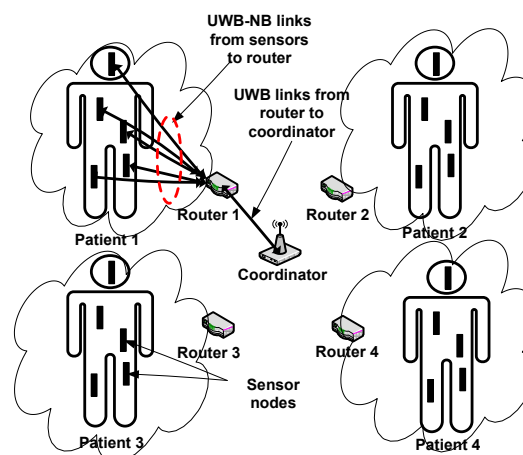

Figure 1. Implementation of UWB WBAN for a multi-human monitoring environment

A Binary Pulse Position Modulation (BPPM) is used as the modulation scheme for the UWB transmission in the WBAN nodes. Energy contained in a bit is dependent on the number of pulses transmitted in that bit period [3]. This concept is used in the suggested MAC protocol in order to optimize the transmit power in

the sensor nodes. Depending on the received signal strength, the parent node (router or coordinator) will send a feedback to the sensor node informing the number of pulses per bit to be generated. Note that this is achieved in the sensor node by varying the duration of the bit, not the pulse repetitive frequency. Hence the receiver node does not have to change the sampling frequency for each sensor node. It just keeps in track of the number of pulses per bit assigned to each sensor node. This can be achieved in the MAC layer. As a result, a single receiver node can be utilized for all the sensor nodes.

2. RESULTS

In order to increase the reliability of data transmission while keeping the power consumption at a minimum level, a narrowband feedback path is introduced to the sensor node. In this design, coordinator node sends a feedback informing the receive signal strength to the transmitting sensor node. Based on this feedback, transmitter dynamically changes the number of pulses sent per bit. Two network topologies for WBAN are simulated. One topology uses a router as an intermediate node between the sensor node and the coordinator node (Topology 1). In the other topology, sensor nodes directly coordinate with the coordinator (Topology 2). Obtained simulation results compares the parameters like packet loss ratio, packet acknowledgement delay, throughput variation and consumed power for different simulation scenarios. These results are shown in Figure 2-5.

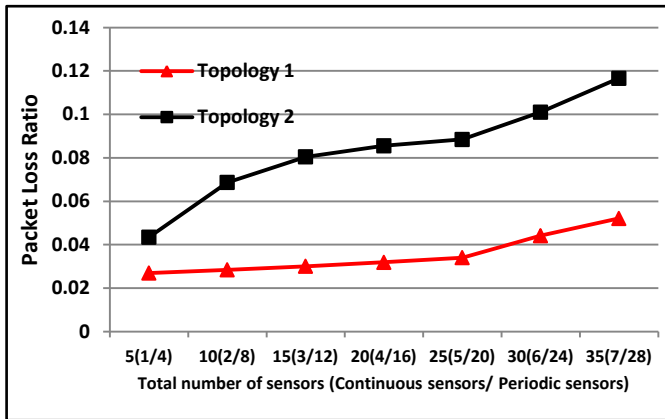

Figure 2. Variation of average Packet loss ratio with the increase of number of sensors for each network topology.

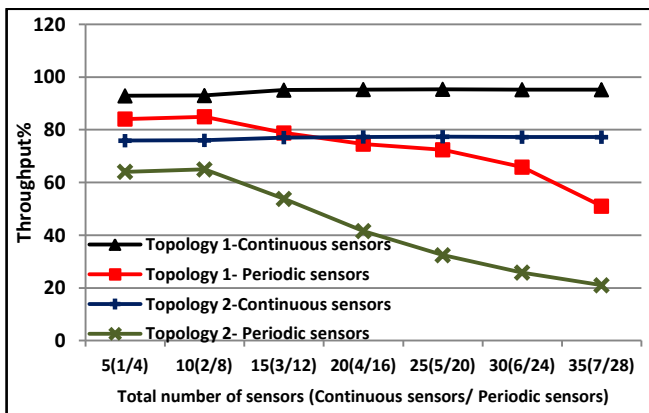

Figure 3. Variation of the percentage throughput for each sensor type in the two simulated topologies.

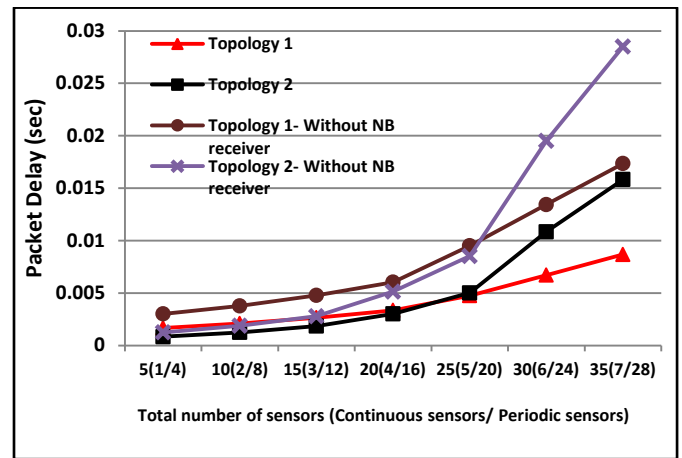

Figure 4. Variation of the average packet acknowledgement delay (seconds) for periodic traffic with increasing number of sensor nodes for two topologies with and without narrow band feedback

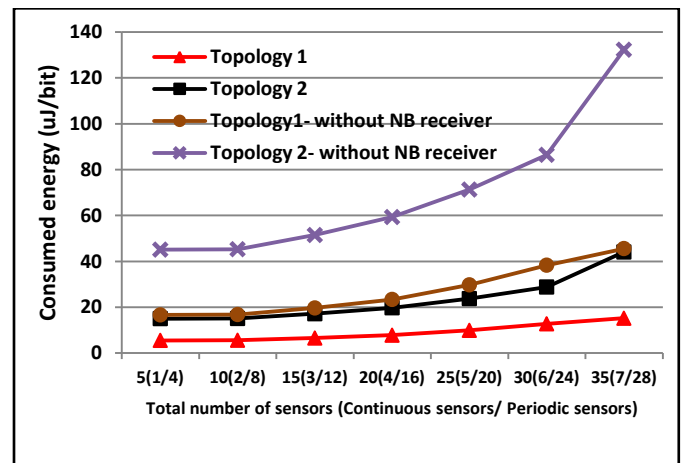

Figure 5. Variation of consumed energy by a sensor node per useful data bit (in μJ) with increasing number of sensor nodes for two topologies and for sensor nodes which use narrowband receivers and sensor nodes which use UWB receivers.

3. REFERENCES

- [1] Yuce, M.R., 2010. Implementation of Wireless Body Area Networks for Healthcare Systems. *Sensors & Actuators: A. Physical*, 162. (July. 2010), 116-129.
- [2] <http://www.ieee802.org/15/pub/TG6.html>, March 2010.
- [3] Keong, H.C. and Yuce, M.R., 2009. Analysis of a multi-access scheme and asynchronous transmit-only UWB for wireless body area networks. *31st Annual International Conference of the IEEE EMBS*. (Minnesota, USA, 3-6 Sept. 2009), 6906 – 6909.