

Interactive Multimedia Services over Open NGN Testbed

Adel Al-Hezmi
Fraunhofer Institute
FOKUS
Berlin, Germany
+49 30 3463 7109

Adel.al-
hezmi@fokus.fraunhofer.de

Oliver Friedrich
Fraunhofer Institute
FOKUS
Berlin, Germany
+49 30 3463 7145

Oliver.friedrich@fokus.fraun-
hofer.de

Stefan Arbanowski
Fraunhofer Institute
FOKUS
Berlin, Germany
+49 30 3463 7179

stefan.arbanowski@fokus.fra-
unhofer.de

Thomas Magedanz
Fraunhofer Institute
FOKUS

Berlin, Germany
+49 30 3463 7229

thomas.magedanz
@fokus.fraunhofer.de

ABSTRACT

Delivering multimedia services over Next Generation Networks challenges the developers to define a unified and converged framework. However the IP Multimedia Subsystem (IMS) defined by the 3rd Generation Partnership Projects offers basic features of such a framework, which enables the provisioning of multimedia services with quality of service and mobility support across heterogeneous networks. The Fraunhofer Institute FOKUS has recently launched the FOKUS Media Interoperability Lab (MIL) which is based on the “Open IMS Playground” testbed. MIL is as an open environment gathering all major IMS core components, and a triple play toolkit originating from own developments as well as major industry players, which can be used by academic and industrial partners for early prototyping of innovative interactive multimedia services and the related system components. This paper introduces the relevant technologies and provides an overview of the lab architecture and the relevant multimedia services at FOKUS. The validation of this architecture is demonstrated with an implementation of different enablers within the Playground as well as an adapted User Agent demonstrating the interaction of streaming and basic NGN telecommunication services.

Keywords

IMS; TISPAN; Next Generation Networks; Multimedia Applications; IPTV, SIP; Testbed;

1. INTRODUCTION

The convergence of telecommunications, the Internet technologies is currently driving the notion of Next Generation Networks (NGN), which drives the evolution of the classic telecommunications environment towards an integrated programmable broadband network environment over wired and wireless access technologies. In this context, IP Multimedia Subsystem (IMS) is the overlay control layer, which has been defined by the 3rd Generation Partnership Project (3GPP) and adapted by several standardization bodies as a service oriented enabler on top of fixed and mobile IP networks.

Delivering multimedia services including telephony, data and TV services with support for interactivity and personalization across different access networks requires a cooperative framework among multiple players involved in the value chain. In order to address this issue, the support for this type of communication and related services needs to evolve to current network infrastructures.

Currently, there are several efforts working on standardizing a common multimedia streaming subsystem over NGN networks worldwide, such as 3GPP IMS [1][2], ETSI TISPAN (European Telecommunication Standard Institute) (Telecoms & Internet converged Services & Protocols for Advanced Networks) [3] or Open Mobile Alliance (OMA) [4]. Furthermore, a number of European research projects have addressed various research topics on ambient networking, personalization, context-awareness and efficient content delivery over cellular network that are conducted by Ambient Networks [5], MobiLife [6] and C-Mobile [7] projects, respectively.

This paper presents the design of a converged architecture framework, which enables the delivery of multimedia services through various access technologies combined with IMS architecture. These efforts resulted in the creation of the Fraunhofer Institute FOKUS Media Interoperability Lab (MIL), which is as an open environment gathering all major IMS core components, and multimedia application toolkit originating from own developments as well as major industry players, which can be used by academic and industrial partners for studying and early prototyping of new triple play services, related components, protocols, and applications. The main objectives of the MIL are to cope with both resource efficiency and service flexibility by the close coupling unicast and broadcast networks, covering the core network and the service enablers.

The outline of this paper is as follows: section 2 gives a brief overview of the important technologies considered in our approach, and their status within standardization activities. Section 3 introduces the architecture of FOKUS Media Interoperability Lab. Section 4 describes application scenarios for the reference implementation as validation within the FOKUS NGN/IMS deployment. The last section presents conclusions and future outlook.

2. RELATED WORK AND TECHNOLOGY BACKGROUND

This section describes briefly the rationale of the main technologies that are considered for the design of the multimedia architecture, describes important considerations in the IMS and within standardization bodies.

2.1 IMS within the Standardization Bodies

While there are definitions from ITU-T and ETSI TISPAN existing for a Next Generation Networks (NGN), it essentially is about the convergence of various networks towards an

architecture that is based upon the Internet Protocol. From an operator's perspective, the IP Multimedia Subsystem (IMS) is the central point within this architecture to offer service in a secure, controllable, chargeable and QoS ensured manner. Specified by 3GPP [1] and 3GPP2 [2], the IMS is now providing also the central elements around which the ETSI TISPAN [3] workgroup is defining its NGN architecture. In a simplified manner, the NGN approach may be represented as a horizontally layered architecture which allows to transport services to users just like traditional network designs (e.g. in ISDN networks), yet it defines service-related functions to be unrelated from underlying technologies and accessible over defined interfaces. For using a service a user is no longer tied to specific access networks, any packet based access network technology may be used. The access networks offer the connection to infrastructures in the service control layer like the IMS for a secure and QoS aware access to SIP services or the Internet on a best effort basis. A detailed description of the components can be found in [8]. Figure 1 depicts the layered approach of the IMS architecture.

In spite of the fact that the IMS is built on point-to-point communication (unicast) model, 3GPP has recently specified in Release 6 the Multimedia Broadcast/Multicast Services (MBMS) [9] that enables cellular networks to support multicast and broadcast transmissions. Although both the IMS and MBMS have similar functions such as authentication, authorization and QoS procedures, the specification does not mention the integration of both subsystems.

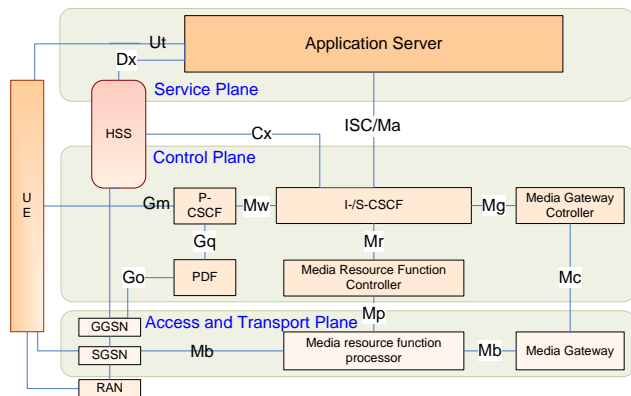

Figure 1: IMS logical layered architecture

While 3GPP IMS focuses on the mobile world, the reference European standardization body for fixed networks is TISPAN [3]. In its NGN architecture TISPAN presents a generic multi-service, multi-protocol, multi-access IP-based framework that aims at becoming the reference model to achieve convergence between PSTN and IP data networks. This model is based upon the concept of cooperating subsystems sharing common components. This architecture enables smooth addition of new subsystems to cover new demands and service classes, and ensures maximum common usage of network resources, applications and user equipment. One of the key subsystems is based on 3GPP IMS Release 6, and it is envisaged to support the provision of SIP-based multimedia services to NGN terminals. TISPAN is currently working on Release 2 with the objective of enabling streaming services (content delivery services like IPTV, streaming and VoD) over NGN with optimized network usage. It is scheduled to be wholly defined throughout 2007 incorporating

a complete IMS-based approach where also the signaling for streaming services is done through the IMS Core and a more loosely coupled solution defining a dedicated streaming subsystem with interfaces to the core functions. Figure 2 shows the TISPAN reference architecture. This architecture is explained in detail in [3].

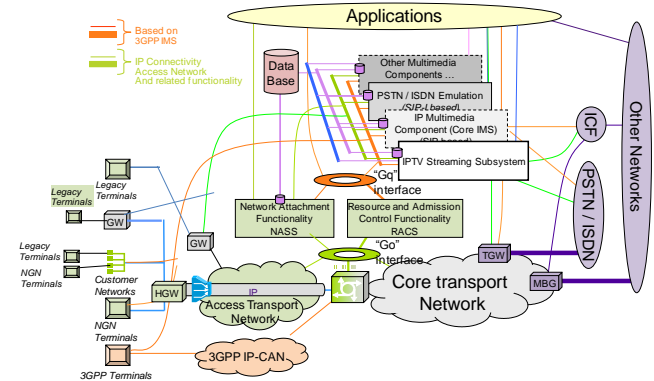

Figure 2: TISPAN NGN reference architecture

3. FOKUS MEDIA INTEROPERABILITY LAB ARCHITECTURE

The key challenges of providing IMS-based multimedia services over fixed and mobile networks are the management of the adaptability, mobility, interactivity, context-awareness and personalization. To enable this vision a basic set of common service functions has been identified and integrated into the FOKUS Labs on top of the basic Open IMS architectures which is depicted in Figure 3. These service functions can be divided into four categories: (1) The Service Provisioning Function providing information on service discovery by so called entry points enabling the connected UEs to find adequate service selection entities. These entities provide the Electronic Program Guides (EPG) including available channels and Video on Demand feeds. (2) The Content Management Function related to all processing tasks performed during content producing, editing and storing; (3) The Session Control Function that is in charge of the whole life cycle of a service based on a defined business model. This includes session management, access control, service composition, personalization, charging, processing and managing of the interactive application; (4) A set of IPTV Media Functions responsible for content delivery to the end user as well as media processing and an efficient utilization of available network resources including QoS and mobility support. On the other hand, several other players are involved within the value chain of provisioning multimedia services, as the Content Provider who creates, owns or is licensed to sell content; the Service Provider who places the contract with the customer for supplying personalized multimedia services based on the network capabilities composed by the network delivery system; (3) the Network Delivery System which is in charge of session management and media delivery; (4) the End-User (consumer) domain where multimedia services are consumed.

Provisioning of end-to-end triple play multimedia services with mobility support and quality of service require a cooperated service framework for interworking all players involved in the delivery process. This will imply new requirements on such a

framework and rise new challenges. These players have to interact smoothly to fulfill the task to provide a whole new service experience to the end user. These requirements were derived from an abstract view to all these players [10].

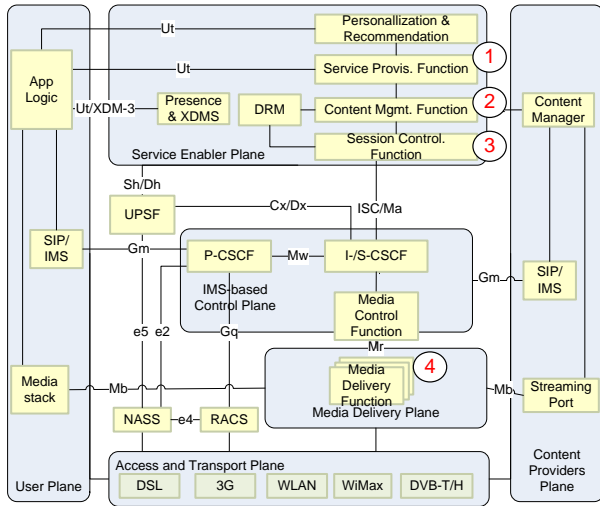

Figure 3: FOKUS IMS-based IPTV reference architecture

As TISPAN NGN is based upon the concept of cooperating subsystems sharing common components and providing a framework for an end-to-end all converged network, it will act as the reference architecture for such cooperated framework. Building upon the capabilities of 3GPP IMS as an overlay control subsystem designed to support heterogeneous IP networks and its ability to deliver integrated voice and data services while providing seamless mobility, it will be used as the foundation convergence platform. As discussed in previous section, TISPAN has also standardized IMS in its reference architecture.

Although the IMS enable the personalization and the interactivity based constantly on a dedicated bidirectional communication channel to each subscriber, the delivery of multimedia contents for huge number of consumers over unicast bearers is inefficient. Therefore multicast and broadcast technologies such as the MBMS or the DVB-H (Digital Video Broadcast) [11] have to be integrated within the IMS network for efficient content delivery. With this regard, the C-Mobile project undertakes the responsibility to enhance the IMS with the MBMS capabilities on cellular network [7].

During designing process of the FOKUS Media Interoperability Lab (MIL) for enabling the delivery of triple play services all these issues have been taken into consideration. Figure 4 shows the high level logical architecture of the lab abstracting from Figure 3 that comprises seven planes as follow:

Access and Transport Plane corresponds to the access and core network. It is the lowest level that offers IP-based transport over wired and wireless access technologies ranging from LAN, DSL, UMTS, DVB, and WiMax. All these access technologies should enable unicast, multicast and broadcast transmission with QoS support and seamless service mobility.

Media Delivery Plane composed as a distributed set of media processor called Media Delivery Function (MDF) align with TISPAN definitions that performs media processing such as

streaming, transcoding, and recording functions and relays media stream from the Content Providers (CPs) to consumers over IP-based unicast, multicast or broadcast bearers. Content might be stored in a central MDF or be distributed among a set of MDFs. The MDF is placed as a mediator between the CP and the Access and Transport Plane. It may be defined as a new entity or is introduced as an evolved Media Resource Function in IMS architecture. Besides, it is responsible for resource scheduling, content distribution, congestion control and content adaptation.

Control Plane: This plane is placed on the top of the access and delivery planes and based on the IMS core that includes the Call Session Control Functions (CSCF), the Home Subscriber Function (HSS) and gateway to the legacy networks. This plane is responsible for session control and service triggering on the service enabler layer based on defined filter criteria stored for each user on the HSS. Furthermore, the Media Function Controller (MCF) is in charge of controlling the MDFs relied on requests triggered by the service enablers. Based on the capabilities of the end-terminal as well as access network – among other factors – the MCF selects an appropriate MDF to perform the relevant media processing functions.

Service Enabler Plane: This plane defines the essential functions that enable the interworking between the service provider, the network operator and the end-user. It contains several enablers that each offers intrinsic and elementary function. Therefore this plane performs all related control functions among these four actors and makes use of all capabilities exposed by the media delivery plane. The design of this plane follows the OMA approach and OMA Service Environment [4]. Enablers can be deployed as standalone services or hosted entities in an application server.

On the top of these enablers and through standardized interfaces applications can compose multiple enabler capabilities in order to offer consumers with more intelligent and personalized services. Besides, sophisticated application development tools and Model Driven Architecture (MDA) tools provide a highly comfortable way to develop services.

User Plane: This plane presents all possible interconnected access technologies either wired or wireless and enables the user to get IP connectivity directly or via an intermediate gateway hosted at user premises. This gateway offers the user the ability to build up a meshed network within his home environment. Every network capable device is connected to this gateway to offer incorporation with other local devices or connect to the core network. Examples are IPTV clients, VoIP client, Set-Top-Boxes (STB), PCs and smart IP devices to control the digital home. It communicates with the IMS core through the Gm, Mb and Ut reference points based on SIP, RTP/RTCP and SHTTP, respectively.

Content Provider Plane: This plane presents the content provider that produces, edits and offers multimedia content to the service provider. Therefore it is the sources of all types of multimedia content. To enable end-user to behave as a CP this plane makes use of all reference points (Gm, Mb, and Ut) that are defined between the end-terminal and the network side.

4. APPLICATION SCENARIOS AND VALIDATION

The service enabler plane of the MIL architecture includes several service enablers that allow developing more intelligent application easily. Part of these enablers as well as applications are developed and deployed on the lab as standalone solution or hosted on an Application Server (AS). FOKUS has developed several types of application servers that are deployed at FOKUS infrastructure. The SIP Servlet Execution Environment (SIPSEE) [12] is one of these AS as a SIP server and is based on the SIP Servlet technology. Demo-applications are used for demonstration purposes and for validation of concepts and software components through the real life.

The next two subsections describe the reference architecture of the implementation and the sequence diagram of an advanced scenario for the injection of personalized advertisements into the live stream which has been deployed in the lab in addition to basic IPTV services.

4.1 Reference Implementation

Figure 4 illustrates the reference implementation of the MIL framework that enables provisioning of multimedia streaming services with interactivity and more mobility features over unicast, multicast and broadcast access network. This solution has been deployed in the lab (MIL) and can be considered as proof of concept for the IMS-based triple play architecture discussed in the last section. The lab is regarded as a show room of the future converged multimedia services covering TV services and NGN services and represents the current research activities.

The ability of delivering triple play services over various access technologies and based on the IMS raises the possibility to combine the advantages of multicast and broadcast mode (e.g. via DVB-T/H or MBMS) for efficient content delivery with high quality at the same time the unicast mode (e.g. via UMTS or DSL) for supporting personalization and interactivity. Furthermore the IMS enables seamless integration of these access networks with quality of service and mobility support as well as ensures secure, chargeable, personalized, and interactive transfer.

The various enablers from section III are developed as SIP Servlet and deployed on the SIPSEE. This includes a triple play session manager called Session Control Function (SCF) and a Content Management Function (CMF). The SMF performs all related service control and session management. The SMF is in charge of session setup of live TV or Video-on-Demand content, bearer selection, mobility across several access networks, group management and triggers the media delivery plane for content delivery by performing the relevant media processing. The CMF is in charge of session setup to and from content providers and distribute the content into the media delivery plane. The Service Provisioning Function (SPF) provides consumers with the information related to service provisioning and enables the consumer to discover the available services or multimedia content. The Presence Server manages and maintains presence information of all consumers. With the context of triple play consumer may share not only his availability information with his buddies but they can announce his current activity (e.g. the TV channel, gaming, etc.).

The IMS core is based on the FOKUS open sources implementation of the P-/I-S-CSCF and the HSS [13]. The media delivery plane is realized through a set of distributed media servers that provide media processing and content delivery from the content provider to the consumers. Each media server called Media Function (MF) can be considered as an enhanced Media Resource Function (MRF) defined in IMS specifications, whereas the improvement tackle the video processing tasks like transcoding, streaming and recording. Furthermore the MF can be controlled by the SMF and the CMF via SIP to play or relay content from a unicast or multicast input to one or a set of unicast or multicast outputs and by performing the required media processing functions. The MF is developed based on the GStreamer libraries [14] that offer most of the needed media processing and delivery functions and the Sofia-SIP library [15] for the realization of the control interface between the SMF through the IMS core and the MPC (Media Processor Controller), which is tightly-coupled with the MF in the current implementation.

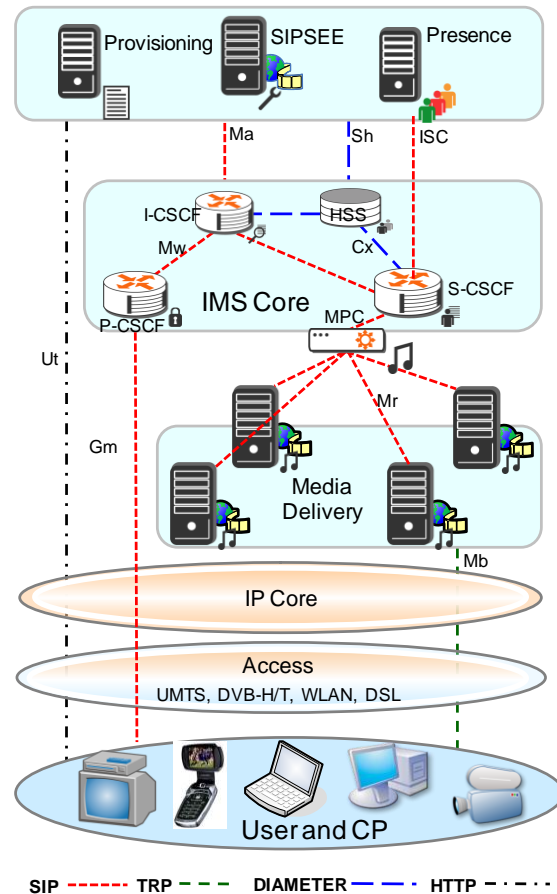

Figure 4:Reference Implementation Architecture

On the user side an advanced IMS multimedia client has been developed for Windows operating system running on PC, notebook or setup-box and based on .NET technology that makes use of all features provided by the network entities through the Gm, Mb and Ut reference points that are defined in the IMS specifications and based on the SIP (Session Initiation Protocol),

the RTP (Real-time Transport Protocol) and http protocol, respectively. The client is facilitated for TV services (live TV and VoD), telecommunication services (telephony, chat, messaging and presence) as well as cross fertilization services such as displaying incoming call, pause the stream of a VoD movie or mute the tone of live TV during a call, watch what your friends currently watching and session mobility of TV session. Figure 5 depicts the GUI of the corresponding client while using IMS presence services and buddy list as an overlay over the current live streaming session.



Figure 5: IMS Multimedia Client

The client can access all IMS-based streaming services as well NGN services through UMTS, WLAN or LAN, while content streaming could be delivered through one of these access technologies or the DVB-H, whereas the testbed is equipped with a DVB-H play-out centre with low-gain (passive) antenna.

Figure 6 shows the real world setup of the MIL test and demo setup:



Figure 6: MIL Demo Room

To create the experience of an interactive and shared experience three plasma displays have been connected to x86-based Home Theatre PCs via a HDMI connection to display SD & HD content provided by the infrastructure.

During the demo these three PC running the Media Client prototype represent three different users in different rooms or households interacting with each other by the various IPTV and telecommunication services provided.

In detail this setup consists of:

- Three Panasonic PZ-700 displays connected to
- Three Acer Aspire Idea HTPC running Windows Vista.
- A HTC Windows Mobile 6 device for VoIP calls from and to the TV sets.
- An instance of the FOKUS Open IMS Core and various Application Servers in the back described in the previous sections.

4.2 Signaling

To evaluate the proposed solution of the IMS-based interactive multimedia framework a scenario for the injection of personalized advertisements has been selected to demonstrate the advantages of IMS-based media delivery. Figure 6 depicts a simplified message flow for this scenario.

Details on how the ad-injection is triggered from the outside, measurements on the switching delay and details on RTSP signaling are out of scope of this description and will be analyzed in one of our following papers just focusing on the different personalized and interactive enhancements of our architecture.

This scenario enables the end-user to watch different live channels where personalized advertisements will be inserted by a managing entity based on the user profile.

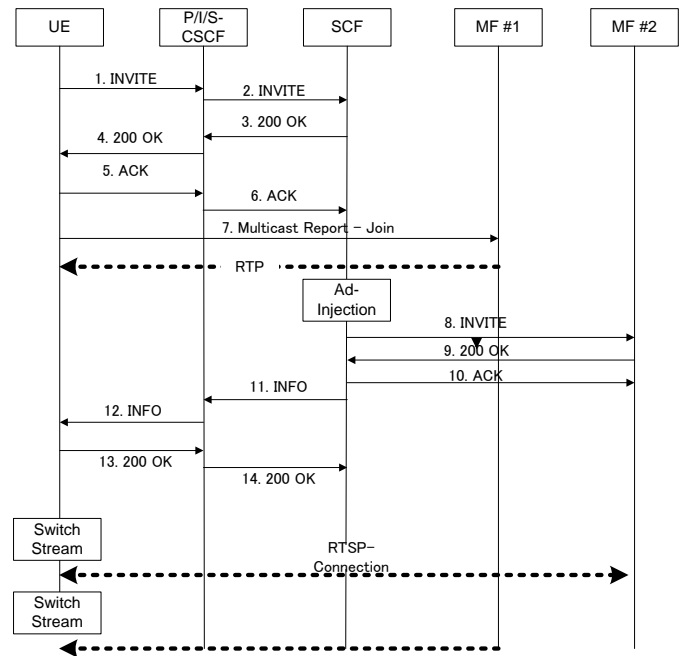

Figure 7: sequence diagram for pers. Ad injection scenario

To simplify the tasks also for the Service Provider each user has been assigned to a specific group matching his behavior and target group.

After selecting a specific channel from the EPG and the setup of the multicast delivery for this service (see messages 1-7 in figure 6) the Session Control Function (SCF) initiates or receives a command for injecting a personalized advertisement. The SCF selects an appropriate Media Function for the advertisement play-out (MF #2 in this case) and forwards this information to the UE (see messages 8-12).

The UE's application logic interprets the received SIP INFO (12) message and switches to the signalled RTSP connection.

After the advertisement has been played out by the client the application logic switches back to the live stream.

It may be noted that one major drawback of this scenario is that the user is missing content while receiving the personalized advertisement.

As this is just an example how the MIL infrastructure is used to signal this service various scenario modifications could solve this problem. The signaling approach may also be used to enable picture-in-picture advertisements blended on the UEs screen. The solution is also useful for Video on Demand scenarios where the (paid) content is paused during the advertisement based on the business model.

5. CONCLUSION AND FURTHER WORK

Traditionally provisioning of streaming services is tightly coupled to particular access technologies such as cable TV, DVB or DSL. The next generation of mobile multimedia streaming service architectures as an IPTV-enabled IMS will allow the development of new and loosely-coupled streaming services provided over an integrated operator controlled infrastructure. Our current prototype shows that this is not just fiction and from our point of view this will be the future for so called 2nd generation IPTV deployments. This work is due to the research efforts in the area of next generation mobile multimedia streaming services at Fraunhofer FOKUS, in particular using IMS and TISPAN as enablers for providing the required integrated management of voice, video and data services.

Future reports of this work will put more emphasis on the personalized advertisement scenarios and will be extended with the ability for interactive shopping and voting which will present our work on more interactive scenarios making use of the backchannel to send direct user feedback to corresponding entities within the network. Moreover, enabling converged TV services connecting to open communities and Web 2.0 is considered for further research.

6. REFERENCES

- [1] 3GPP, TS 23.228. IP Multimedia Subsystem; (stage 2). www.3gpp.org
- [2] <http://www.3gpp2.org>
- [3] DTR 00001, Telecommunications and Internet Converged Services and Protocols for Advanced Networking (TISPAN); Release 1 Definition.
- [4] "OMA Service Environment", Approved Version 1.0.2 – 08 Aug 2005, www.openmobilealliance.org
- [5] Norbert Niebert, Andreas Schieder, Henrik Abramowicz, Göran Malmgren, Joachim Sachs, Uwe Horn, Christian Prehofer and Holger Karl, "Ambient Networks – An Architecture for Communication Networks Beyond 3G", IEEE Wireless Communications, Vol. 11, No. 2, April 2004, pp. 14-21.
- [6] IST-2004-511607 MobiLifeD33 (D5.2) v1.0 "State-of-the-Art in Service Provisioning and Enabling Technologies", November 30, 2004.
- [7] C-MOBILE project web page: <http://c-mobile.ptinovacao.pt>
- [8] ETSI TISPAN ES2020, (2005) "Resource Admission Control Subsystem (RACS) Architecture".
- [9] 3GPP TS 23.246: "Multimedia Broadcast/Multicast Service; Architecture and Functional Description", Release 6
- [10] Adel Al-Hezmi; Oliver Friedrich; Stefan Arbanowski; Thomas Magedanz; "Requirements for an IMS-based Quadruple Play Service Architecture"; Network, IEEE; Volume 21, Issue 2, March-April 2007 Page(s):28 – 33; Digital Object Identifier 10.1109/MNET.2007.334309
- [11] ETSI TS 102 034, Digital Video Broadcasting (DVB); Transport of MPEG2 Based DVB Services over IP Based Networks
- [12] K. Knuettel, T. Magedanz, L. Xie: "SIP Servlet Execution Environment (SIPSee) - An approved IMS SIP Application Server for Converged Applications", International Conference on Intelligence in Networks (ICIN) 2006, Bordeaux, France, May 31, 2006, <http://www.icin-conference.com/>
- [13] D. Vingarzan, P. Weik, T. Magedanz: "Development of an open source IMS core for emerging IMS testbeds", Special Issue on IMS, Journal on Mobile Multimedia (JMM), Vol.2 No., Rinton Press, Princeton, USA, 2006, <http://www.rintonpress.com/journals/jmm/>
- [14] GStreamer library, <http://gstreamer.freedesktop.org/>
- [15] SIP Sofia library, <http://sofia-sip.sourceforge.net>