

Feasibility Study on Spectrum Sharing type Cognitive Radio System with Outband Pilot Channel

Kentaro Ishizu, Homare Murakami, Hiroshi Harada

New Generation Wireless Research Center

National Institute of Information and Communications Technology (NICT)

Yokosuka, Japan

Abstract— This paper proposes a spectrum sharing type cognitive radio system integrated with a dedicated radio system called out-of-band pilot channel (OPC). The OPC notifies the radio configuration information of cognitive base station (CBS), such as operational frequency and PHY/MAC parameters, to cognitive terminal (CT) so that the CT does not need to sense throughout a large range of potential frequency bands and immediately configure itself to connect to the CBS. Experimental evaluation shows that the proposed system takes 2.80 seconds to obtain the information on accessible CBS, whereas the conventional system without the OPC takes 8.09 seconds for sensing just 4 frequency channels. It is confirmed that the proposed system achieves a drastic time reduction to obtain the CBS radio configuration information.

Keywords—cognitive radio system; spectrum sharing; out-of-band signaling; prototype; white space

I. INTRODUCTION

More and more wireless communication technologies have been emerging in line with the growing demands and requirements for mobile communications. Therefore, frequency bands suitable for mobile wireless communications especially from the UHF band to 6GHz band have been already exhaustively assigned. On the other hand, expectations from users for broader bandwidth and stable communications required for various multimedia applications such as video streaming and huge file exchanges are growing. Given this situation, it is urgent to establish a way forward to increase spectrum utilization efficiency in order to accommodate more users and further applications.

One of the innovative ways to overcome this issue is to share the same spectrum bands with multiple radio systems. For spectrum sharing, systems with different priorities are assumed. High priority users to access a frequency bands are called a primary users. The primary users shall be protected from radio interferences caused by other users with lower priority, called secondary users. The secondary users can use the frequency band only when the primary users are not interfered. For coexisting of the two types of users, cognitive radio technologies of cooperative management with other radio nodes, sensing, and reconfiguration are required to be integrated as a system capable of the spectrum sharing.

The sensing is required in multiple layers. Firstly, energy measurement is required to detect existence of and/or interference from other radio systems. Next, PHY/MAC level analysis of received signals is required to identify radio

systems nearby. These sensing takes very long time to complete because the potential spectrum range of spectrum sharing is quite large, which is unpractical especially for mobile communications. For example, using authors' previous prototype system composed of original multiband hardware and management software which is operated in frequency bands from 400MHz to 6GHz, it is observed that the sensing takes approximately 42 seconds to detect spectrum energy and identify operated system on different 177 frequencies over 2.4-2.6GHz and 5GHz bands [1]. The time is unendurably long to wait for to find an accessible radio system after disconnection from another radio system. Shortening sensing time is one of the key issues to address for practical spectrum sharing on a potentially large range of frequency band.

There are active investigations and institutionalizations by national radio regulatory agencies in the world regarding spectrum sharing of so-called TV white space (TVWS) which is TV channels unused geographically and/or temporally. FCC in U.S. has published the Second Report and Order in the Matter of Unlicensed Operation in the TV Broadcast Bands in November 2008 [2] and its revision in September 2010 [3]. These documents allow the secondary operation in TVWS for portable devices. The similar actions are considered in Ofcom of U.K., Infocomm Development Authority (IDA) of Singapore, Canada, and several European countries. In Japan, the Ministry of Internal Affairs and Communications (MIC) has established an investigation team for the utilization of TVWS. Also, international standardizations have been started for the spectrum sharing type wireless communication systems including TV bands such as IEEE 1900.4a, IEEE 802.11af, IEEE 802.19.1, IEEE 802.22.1, and ECMA 392. Considering above mentioned circumstances for utilizations of the TVWS, of which bandwidth is very large, the sensing time issue is getting considerably important.

In this paper, a special wireless communication method, called Out-of-band Pilot Channel (OPC), dedicated to exchanging radio configuration information is proposed on top of the spectrum sharing type Cognitive Radio System (CRS). In the proposed CRS, both cognitive base station (CBS) and cognitive terminal (CT) communicate over the OPC regarding the radio configuration information including operational frequency band and PHY/MAC parameters. The CBS and CT are capable of communicating different PHY/MAC in multiple frequency bands by using reconfigurable FPGA board for baseband signal processing and multiband RF modules based on the SDR technology. The CT reconfigures itself according

to the received information from the OPC so as to access the CBS immediately without sensing all potential frequency bands. Because the CT is reconfigurable in terms of frequency and PHY/MAC, the CT can switch its communications of either OPC or user data using only one RF board, which reduces the number of RF and related modules that affect the cost, size, and power consumption of the CTs. Using prototype systems with and without the OPC, the advantages of the proposed system are shown based on detailed sensing time measurements.

II. SYSTEM ARCHITECTURE AND FUNCTIONS FOR SPECTRUM SHARING

This section clarifies a deployment scenario of the spectrum sharing with the OPC functionality and proposes system architecture and functions of the CRS to realize the scenario.

A. Deployment Scenario

There are two types of approaches for the CRSs [4]. One is heterogeneous type CRS which improves throughput and also realizes seamless communications by intelligently sensing its operational frequency bands and finding appropriate existing RANs. The other is spectrum sharing type CRS which utilizes vacant frequency bands that are not used as mentioned in the previous section. Deployment of the most efficient radio utilization requires an integration of two types of CRS, of which concept is shown in Fig. 1. However, this paper focuses on the investigation of the spectrum sharing type approach and its integration with the heterogeneous type is out of the scope.

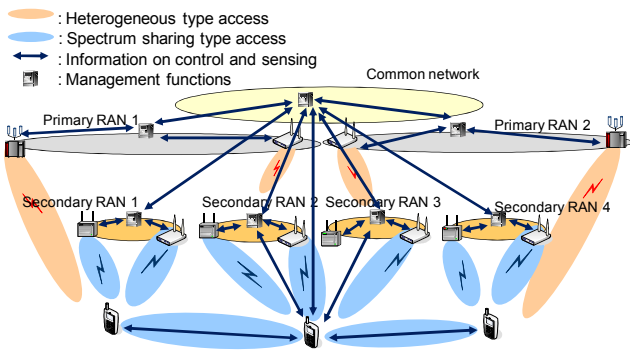

Figure 1. Concept of cognitive radio systems integrating heterogeneous type and spectrum sharing type

The approach to spectrum sharing type CRS is to utilize unused frequency bands that are vacant temporally and/or geographically. These unused frequency bands include TV bands, microphone bands, and military bands. For the consideration of the spectrum sharing, two kinds of operators are assumed; primary operator and secondary operator. As shown in Fig. 1, the primary operators deploy RANs with base stations and/or access points. This RAN is called primary RAN and operated on licensed frequency bands. The secondary operators deploy RANs which are operated on white space or frequency bands allowed by the primary operators. The secondary RANs are connected to one of the

primary RANs selected by the secondary operators. The CTs select the best RANs from the CTs' perspective and connect to them. The CTs select RANs from the primary RANs or the secondary RANs. Secondary RANs may have accesses to multiple primary RANs. Also, the CTs may have accesses to multiple primary/secondary RANs. The CTs may connect to the network by relaying or routing via other CTs which are connected to one of the RANs. Spectrum sharing type CRS is utilized for the communications between CTs. The common network and each RAN have their own management functions. The management functions in RANs manage radio systems in the same RAN. Information for controls and measurements is exchanged among the management functions and the CTs.

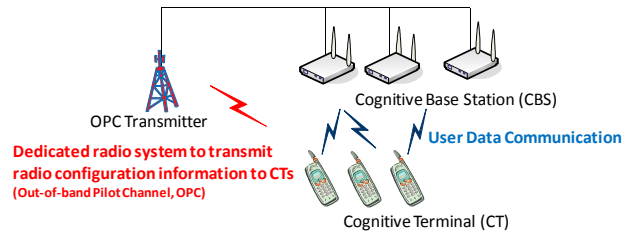

Figure 2. Out-of-band Pilot Channel for spectrum sharing type CRS

On top of user data communication of the CRS shown in Fig. 1, additional radio system called Out-of-band Pilot Channel (OPC) transmitter is deployed. As shown in Fig. 2, the OPC transmitter is dedicated to sending out radio configuration information including operational frequency and PHY/MAC parameters of the CBSs. When the CBSs are ready to operate, the CBSs notify its radio configuration information to the OPC transmitter. Then, the OPC transmitter sends out the information using a known PHY/MAC in known frequency. The CTs watch this frequency and reconfigure themselves so as to access the CBSs once the information is received.

B. System Architecture

System architecture for the management of spectrum sharing type CRS is composed of three main parts as shown in Fig. 3; CBS, CT, and packet based network. The CBS includes CBS reconfiguration manager (CBSRM), CBS measurement collector (CBSMC), and CBS reconfiguration controller (CBSRC). CBSRM makes decisions on reconfigurations of the CBS. CBSMC collects measurements of the CBS. CBSRC controls reconfigurations of the CBS. Also, the CT includes terminal reconfiguration manager (TRM), terminal measurement collector (TMC), and terminal reconfiguration controller (TRC). TRM makes decisions on reconfigurations of the CT. TMC collects measurements of the CT. TRC controls reconfigurations of the CT. The packet based network includes network reconfiguration manager (NRM). NRM makes decisions on reconfigurations of the CBS. OPC transmitter has interfaces with CBSRC and TRM so that the radio configuration information of CBSs are carried to the CTs via the OPC transmitter.

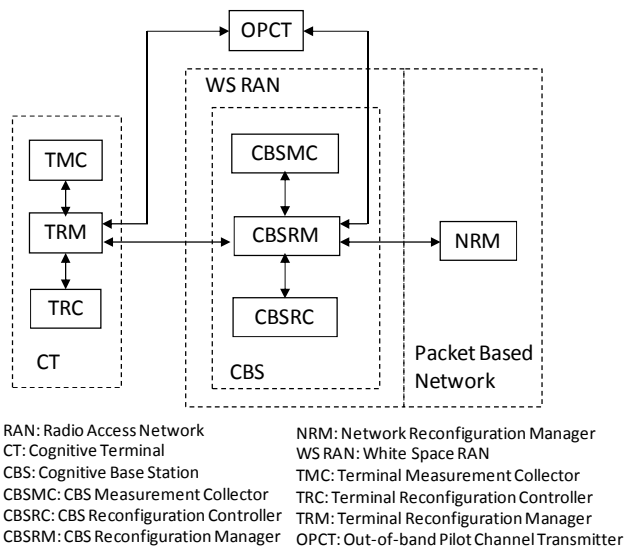

Figure 3. A system architecture of spectrum sharing type CRS with the Out-of-band Pilot Channel functionality

C. Functions

The CBS operates in different center frequencies with different PHY/MAC. Before its operation, the CBS conducts measurements of energy to detect interference of surrounding radio environment throughout its potential operational frequency range. Then, the CBS decides a frequency to operate on. For this decision, the CBS takes frequency band priority into account. The priority is configured per frequency band by its operator. The CBS selects an unused frequency with the highest priority, reconfigures its operational frequency according to the decision, and starts its service to CTs. During the operation, the CBS continuously checks radio interferences from other nodes by analyzing received signals in PHY/MAC level. If the interference is detected, the CBS restarts the energy measurements process and change its operational frequency to avoid the interference.

The OPC transmitter sends out radio configuration information continuously. The radio configuration information includes operational frequency, PHY/MAC parameters, and CBS IDs such as MAC address and SSID.

The CT receives the radio configuration information over the known OPC. According to the received information, the CT configures itself and accesses the available CBS at the moment. When multiple CBSs are available, the CT selects the one with the highest priority. The priority is configured associated with each CBS ID by its user. In case when the information is not received over the OPC, the CT switches to non-OPC mode. In the non-OPC mode, the CT performs energy measurements throughout the potential operational frequency range. On frequencies where energy over pre-defined detection level is detected, the CT tries to identify the PHY/MAC and related parameters that the CBS operates by analyzing received signals in PHY/MAC level. When communications with the CBS are disconnected, the CT restart to obtain the radio configuration information over the OPC.

The TRM and CBSRM report measurements to the NRM. The measurements are accumulated and analyzed in the NRM and feedback information is created for TRMs. The feedback information may be a list of CBSs dealing with less traffic to recommend to the CTs, notification of policies for CTs to select CBSs, and so on. There are various investigation topics on how to create the feedback information and how to process in CTs for performances improvements of the CRS, but this paper deals with only the CBS and CT with the OPC functionality. Collaboration with the NRM is left for further investigations.

III. PROTOTYPE SYSTEM

A prototype system for the proposed CRS is designed and implemented based on the system architecture and functions described in the previous section. The CRS is operated in frequency bands from 400MHz to 6GHz for user data communication. The CRS also utilize 720MHz band for OPC. Since the frequency band for the OPC is not standardized, 720MHz band is adopted for the empirical evaluation purpose. This section details hardware architecture and software configuration of the prototype system.

A. Hardware Architecture

In the prototype, the OPC transmitter is implemented inside the CBS. Therefore, the CBS is composed of user data communication part and OPC part. Each part is composed of CPU, FPGA, and RF boards. The CPU board executes processing of layer 3 and above. The FPGA board executes PHY baseband processing and MAC. The RF board executes PHY modulation and demodulation. As shown in Fig. 4, the two CPU boards are connected via Ethernet and radio configuration information is provided from the user data communication part to the OPC part over IP. The CPU and FPGA board are connected via CPU bus. The FPGA and RF boards are connected via analogue I/O and control bus. The RF board has four RF interfaces according to frequency bands. The CPU board of the user data communication part has an Ethernet port to connect to backbone network. The hardware architecture of the CT is the same as the user data communication part of CBS. The CT has additionally a display board connected to the CPU board.

Specifications of the user data communication and the OPC are shown in table I and II respectively. For both specifications, its PHY/MAC is compatible with IEEE 802.11a but only the frequency range and sub-carrier modulation are different. The user data communication is capable of selecting operational frequency from wider range of frequency and higher bit rate. On the other hand, the OPC is capable of using only fixed frequencies and slow bit rate. This is because narrower frequency band of 4.15 MHz is assigned to the OPC compared with 20MHz assigned to the user data communication. Because the OPC should be more reliable communications, BPSK for OFDM sub-carrier and higher output power are used for the OPC.

The hardware is completely developed from the scratch partly taking radio modules developed in our former R&D [1].

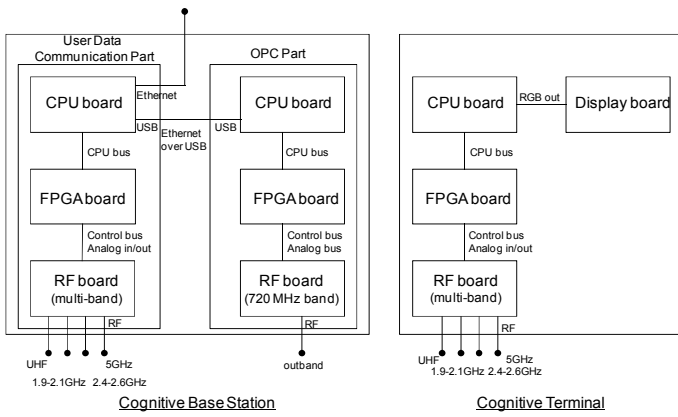

Figure 4. Hardware architecture of the CBS and CT

TABLE I. SPECIFICATION OF USER DATA RADIO DEVICE

| Items | Description |
|--------------------------|--|
| Frequency | (TX) 2.4-2.6GHz, 5GHz (RX) UHF, 1.9-2.1GHz, 2.4-2.6GHz, 5GHz |
| Occupied freq. bandwidth | 20MHz |
| Bit rate | 24Mbps |
| PHY modulation | OFDM (Total 52 carriers, 48 carriers for data, 4 carriers for control) |
| Sub-carrier modulation | 16QAM, FEC (coding rate 1/2, constraint length 7) |
| MAC | IEEE 802.11a compatible |
| Output power | +10dBm |

TABLE II. SPECIFICATION OF OPC RADIO DEVICE

| Items | Description |
|--------------------------|--|
| Frequency | 720.00 or 722.00MHz |
| Occupied freq. bandwidth | 4.15MHz |
| Bit rate | 1.5Mbps |
| PHY modulation | OFDM (Total 52 carriers, 48 carriers for data, 4 carriers for control) |
| Sub-carrier modulation | BPSK, FEC(coding rate 1/2, constraint length 7) |
| MAC | IEEE 802.11a compatible |
| Output power | +20.66dBm |

B. Software Architecture

Management software is required to control the hardware of both CBS and CT. Design of software architecture composed of functional elements is shown in Fig. 5. The CBS has the user data communication controller and the OPC controller. These controllers run on different CPU board of the CBS shown in Fig. 4. In the user data communication controller, the CBS Management conducts measurements and reconfigurations of the data communication part triggered by the CBSRC and CBSMC via rCFG_MEDIA_SAP defined in IEEE 1900.4 [4]. In this controller, there are three waveforms; 802.11a, 802.11b, and sensing. The CBSMC/CBSRC can specify one of the waveforms to write onto the FPGA board. When 802.11a waveform is taken, the user data communication part of the hardware behaves as IEEE 802.11a

system. When the sensing waveform is taken, it starts to measure energy and identify PHY/MAC on given frequency range as described in section II.C. Regarding the OPC controller, it does not necessarily have the capability of reconfiguration. But, for investigation purpose, OPC is realized by the SDR technology so that PHY/MAC parameters of the OPC can be changed by software. The transmission from the OPC controller is started once the radio configuration information is obtained from the user data communication controller. The transmission interval of the information is set to 1 second.

Software architecture of the CT is similar to the user data communication controller of the CBS. TRM/TRC/TMC is implemented instead of CBSRM/CBSRC/CBSMC. Waveforms in the CT are 802.11a, 802.11b, OPC, and sensing. The waveform of OPC is to receive the radio configuration information over the OPC. Since the CT has only one RF, the CT switches these waveforms to operate required radio system.

The operating system on the CPU board is Linux. The software is implemented as a set of portable software modules that are able to run on various hardware platforms.

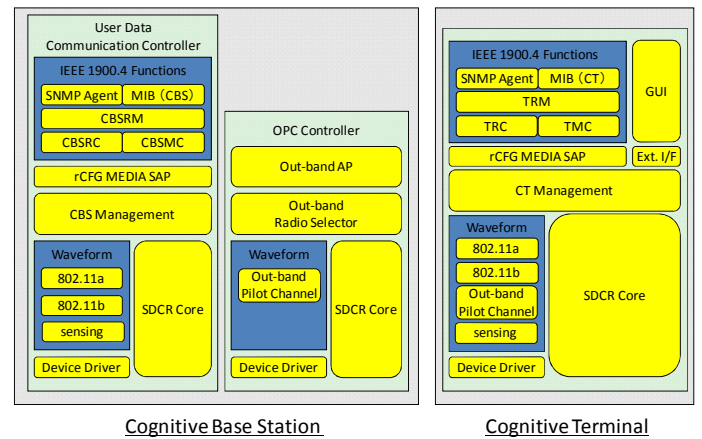

Figure 5. Software architecture of CBS (left) and CT (right)

IV. EXPERIMENTS FOR FEASIBILITY STUDY

An evaluation environment was configured as shown in Fig. 6 where WiMAX BS and terminal, CBS, and CT were placed in a radio shield room. It is assumed that the WiMAX BS/terminal was operated in the primary RAN and the CBS / CT in the secondary RAN. Variable attenuators are inserted between the WiMAX BSs and its antenna to change the received signal strength of the WiMAX BS on the CBS. The operation frequency, bandwidth, and the output power of the WiMAX system are set to 2587MHz, 10MHz, and 40dBm, respectively.

The operational frequency and priority of the CBS is configured so that the frequency band from 2570 to 2591MHz has the highest priority. Therefore, this band is firstly checked whether there is any interfering radio system by comparing the received signal strength with the detection level which is preconfigured to -85dBm.

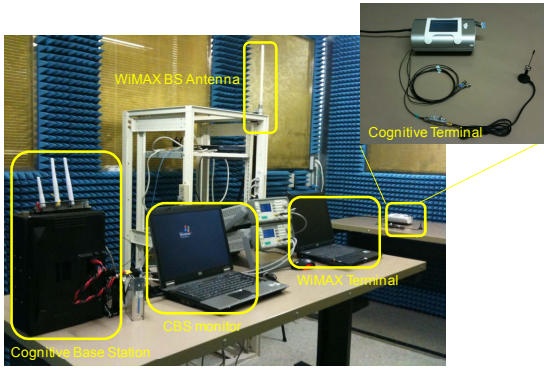

Figure 6. Evaluation environment in shield room

In the beginning of the experiment, the variable attenuator is set to 40dBm and after this the CBS was turned on. The CBS started to sense the highest priority of the frequency band 2.5GHz and started to operate in 2.5GHz because no signal was detected in the same frequency. Next, the variable attenuator is set to 0dB and then the CBS was restarted. The CBS started to sense 2.5GHz and detected signal from the WiMAX BS at more than the detection level. Therefore, the CBS skipped 2.5GHz and started to sense the next priority frequency band 2.6GHz. Since there was no signal detected in 2.6GHz, the CBS started to operate in 2.6GHz. During the experiments, the radio configuration information was continuously transmitted over the OPC.

For investigation of the CT sensing, the CBS was temporally configured to operate in 2.5GHz. The CT's sensing time was measured in both cases where the OPC is enabled and disabled. The two cases of the breakdown time of CT's sensing are shown in Fig. 7. Numbers on the left side are times in second taken in indicated period. Each time is an average of three measurements.

In case of the OPC disabled, the TRM requests the TRC to activate the sensing by loading the sensing waveform to the FPGA board (a1). After this, response message (a2) is sent back to the TRM. Then, for each frequency, the TRM configures the sensing frequency to the TRC (a3, a4) and retrieves measurements from the TMC (a5, a6). After this, the measurements are analyzed to decide an operational frequency. The sensing takes 1.7 second per one frequency, which was the dominant time.

Next, in case of the OPC enabled, the TRM requests the TRC to activate the OPC reception by loading the OPC waveform to the FPGA board (b1). After its response message is sent back to the TRM (b2), the TRM receives the radio configuration information from the OPC transmitter (b3). Then, the TRM request to stop the receiving (b4) and its response is sent back to the TRM (b5). Time between (b2) and (b3) depends on the interval time of the OPC transmission. In the prototype, as the interval is 1 second, the time between (b2) and (b3) is less than 1 second. The dominant time was 2.54 second which was between (b1) and (b2) to load the OPC waveform to the FPGA.

As a result of above analysis, it is confirmed that spectrum sharing type CRS with the OPC enabled is obviously

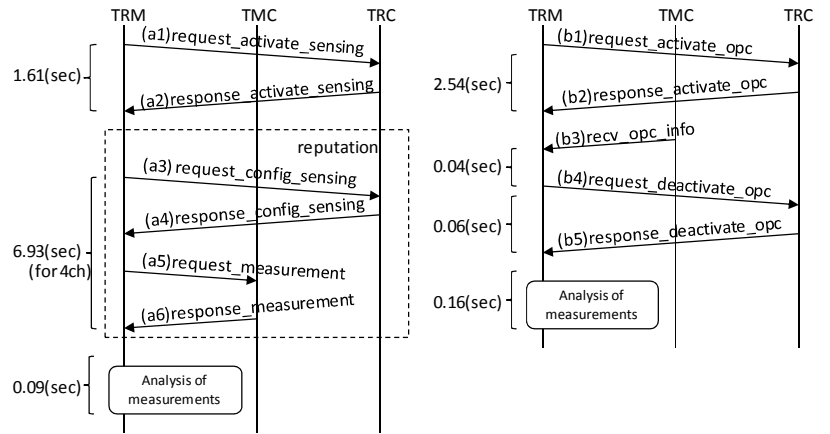

Figure 7. Breakdown sensing time of CTs with OPC disabled (left) and enabled (right)

faster than that disabled. However, it took totally 2.80 seconds even in the former case, which is still long for real-time applications such as voice and video. Time reduction in FPGA configuration is one of the issues to be solved in the future. One approach to avoid this issue is that the CT has an independent radio system for OPC and receives on the OPC in parallel with the user data communication although there are disadvantages as mentioned in introduction.

V. CONCLUSION

This paper proposed a spectrum sharing type cognitive radio system integrated with a dedicated radio system called out-of-band pilot channel (OPC). The OPC notifies the radio configuration information of CBS, such as operational frequency and PHY/MAC parameters, to the CT so that the CT need not to sense throughout a large range of potential frequency bands and immediately configures itself to connect to the CBS. Experimental evaluation showed that the proposed system took 2.80 sec. to obtain the CBS information, whereas the conventional system without the OPC took 8.09 sec. for sensing just 4 frequencies. It is confirmed that the proposed system achieved a drastic reduction of the sensing time. The field experiments using the proposed system are planned to clarify and address practical deployment issues.

ACKNOWLEDGMENT

This research was partly conducted under a contract of R&D for radio resource enhancement, organized by the Ministry of Internal Affairs and Communications, Japan.

REFERENCES

- [1] H. Harada, H. Murakami, K. Ishizu, S. Filin, G. Miyamoto, H. N. Tran, Y. D. Alemseged, and C. Sun, "Research and Development on Heterogeneous Type and Spectrum Sharing Type Cognitive Radio System," CrownCom 2009, Jun. 2009.
- [2] FCC 08-260, "Second Report and Order and Memorandum Opinion and Order," Nov. 2008.
- [3] FCC 10-174, "Second Memorandum Opinion and Order," Sep. 2010.
- [4] "IEEE Standard for Architectural Building Blocks Enabling Network-Device Distributed Decision Making for Optimized Radio Resource Usage in Heterogeneous Wireless Access Networks," IEEE 1900.4-2009, Feb. 2009.