

# Realization of TDD Two-way Multi-hop Relay Network with MIMO Network Coding

Keiichi Mizutani<sup>1</sup>, Yutaro Kida<sup>1</sup>, Takehiro Miyamoto<sup>2</sup>, Kei Sakaguchi<sup>1</sup> and Kiyomichi Araki<sup>1</sup>

<sup>1</sup>Tokyo Institute of Technology 2-12-1 Ookayama, Meguro, Tokyo, Japan, 152-8552

<sup>2</sup>Nihon Dengyo Kosaku Co., Ltd. 7-4 Nissai-Hanamizuki, Sakado, Saitama, Japan, 350-0269

Email: {mizutani, kida, sakaguchi, araki}@mobile.ee.titech.ac.jp, miyamoto-takehiro@den-gyo.com

**Abstract**—This paper develops the first prototype hardware for TDD two-way multi-hop relay network with MIMO network coding. Since conventional wireless multi-hop relay networks have a drawback of low data rate, TDD two-way multi-hop relay networks have been studied as a solution to realize high data rate recently. In the networks, forward and backward streams are spatially multiplexed by using interference cancellation techniques such as MIMO beamforming or MIMO network coding. In this paper, demonstration system for TDD two-way multi-hop relay network with MIMO network coding (called 2-way relay network hereafter) is developed by using the prototype hardware. In the demonstration system, each transmitter and receiver performs network coded broadcast and MIMO multiple access respectively. By using the demonstration system, network throughput is measured in a real indoor environment to prove the realization and effectiveness of the 2-way relay network. The network throughput of the 2-way relay network is about twice as large as that of the simple TDD one-way multi-hop relay network (1-way relay network), and higher than that of the direct link at all average end-to-end SNRs. From the result, the realization and effectiveness of the 2-way relay network is proved in the real indoor environment.

## I. INTRODUCTION

Recently, wireless multi-hop relay networks have attracted much attention because of its flexibility and connectivity, and are expected to be applied for public wireless networks, wireless sensor networks, and wireless utility networks [1]. Particularly, time division duplex (TDD) based two-way multi-hop relay network using network coding [2], [3], [4] with MIMO multiple access [5] has been studied as a high data rate multi-hop relay network. In this network, interference cancellation schemes are introduced, so that forward and backward streams can be spatially multiplexed. However, such TDD two-way multi-hop relay networks have not been implemented and realized with real hardware.

In this paper, prototype hardware and demonstration system are developed for the proof of TDD two-way multi-hop relay networks with MIMO network coding (called 2-way relay network hereafter) in real environment. The developed prototype hardware consists of an array antenna, an RF board, a baseband board, and a CPU. Furthermore, MIMO network coding and network synchronization [6] are implemented in the prototype hardware and the CPU.

The demonstration system consists of three hardware nodes. The first node is the source and destination of forward and backward streams respectively. The third node is the destination and source of forward and backward streams respectively.

The second node performs two-way relay. Firstly, appropriate Tx and Rx timing of each node is generated by the network synchronization. After that, the two-way multi-hop relay is performed by using MIMO network coding. These operations can be checked through a user interface.

Finally, network throughput is measured in an indoor environment to prove the realization and effectiveness of the 2-way relay network. For evaluation and comparison of the network throughput of the 2-way relay network, a direct transmission system without the help of the relay node (Direct link), and a TDD one-way multi-hop relay network (1-way relay network) in which the forward and backward streams are transmitted in different TDD phases are established as two optional systems of the demonstration. From the results of the network throughput measurement, we can find that 2-way relay network can achieve network throughput close to the upper bound even at low average end-to-end SNRs. Additionally, the measured network throughput of the 2-way relay network performs twice of that of the 1-way relay network at all average end-to-end SNRs, and also, the measurement results show that the 2-way relay network can achieve a same network throughput with the direct transmission at high average end-to-end SNRs. Thus, our experiment proves the realization and effectiveness of the 2-way relay network in the real indoor environment.

The paper is organized as follows. The TDD two-way multi-hop relay network using MIMO network coding is explained in Sect. II. In Sect. III, the overview of the prototype hardware and demonstration system are shown. In Sect. IV, measurement results of the network throughput using the prototype hardware in an indoor environment are presented. Finally, Sect. V concludes this paper.

## II. TDD TWO-WAY MULTI-HOP RELAY NETWORK USING MIMO NETWORK CODING

In order to reduce the required number of phases for two-way transmission and to achieve higher network throughput, MIMO network coding has been introduced in TDD multi-hop relay network [5] as shown in Fig. 1. In the MIMO network coding, two-way streams are relayed simultaneously. Each Tx node broadcasts a network coded signal, and each Rx node receives two signals from the adjacent nodes by using MIMO multiple access. In Fig. 1, each node is equipped with two antennas. Each Tx node uses single antenna for broadcast,

while each Rx node uses two antennas for MIMO multiple access.

At the  $t$ th timeslot, when the 1st and 3rd nodes are Tx, transmit binary messages  $s_1(t)$  and  $s_3(t)$  are modulated and coded to  $x_1(t)$  and  $x_3(t)$ . At the 2nd receiver node, received signal  $y_2 \in \mathcal{C}^2$  can be modeled as,

$$\mathbf{y}_2 = [\mathbf{h}_{21} \ \mathbf{h}_{23}] \begin{bmatrix} x_1(t) \\ x_3(t) \end{bmatrix} + \mathbf{n}_2 \quad (1)$$

$$= \mathbf{H}_2 \mathbf{x}_2 + \mathbf{n}_2, \quad (2)$$

where  $\mathbf{h}_{ij} \in \mathcal{C}^2$  is the channel vector between the  $j$ th and  $i$ th nodes,  $\mathbf{n}_i \in \mathcal{C}^2$  is the additive white Gaussian noise vector at the  $i$ th node, and  $\mathbf{H}_i \in \mathcal{C}^{2 \times 2}$  is the aggregated channel matrix that will be used for MIMO multiple access. In this paper, interference cancellation is done by using Zero-Forcing scheme, which is a simplest MIMO receiving algorithm as follows,

$$\tilde{\mathbf{x}}_2 = \begin{bmatrix} \tilde{x}_1(t) \\ \tilde{x}_3(t) \end{bmatrix} = \mathbf{H}_2^{-1} \mathbf{y}_2, \quad (3)$$

where  $\tilde{\mathbf{x}}_i \in \mathcal{C}^2$  is an estimated transmit signal vector. The estimated signal  $\tilde{x}_i(t)$  is decoded and demodulated to a binary message  $\tilde{s}_j(t)$ .

In the multi-hop relay network, the relay node has a priori knowledge described as,

$$s_i^F(t) \equiv s_{i-1}^F(t-1) \quad (4)$$

$$s_i^B(t) \equiv s_{i+1}^B(t-1). \quad (5)$$

By using the priori knowledge and network coding, binary message  $s_2(t+1)$  is generated as,

$$s_2(t+1) = s_1^F(t) \oplus s_3^B(t) \quad (6)$$

$$= s_2^F(t+1) \oplus s_2^B(t+1), \quad (7)$$

where  $\oplus$  denotes the exclusive OR (XOR) operator. This network coded binary signal is broadcast to the 1st and 3rd nodes. At the 1st and 3rd nodes, the desired messages  $s_2^B(t+1)$  and  $s_2^F(t+1)$  can be obtained by using the received message  $\tilde{s}_2(t+1)$  and network decoding as,

$$\begin{aligned} s_2^B(t+1) &= \tilde{s}_2(t+1) \oplus s_1^F(t) \\ &= \tilde{s}_2(t+1) \oplus s_2^F(t+1) \end{aligned} \quad (8)$$

$$\begin{aligned} s_2^F(t+1) &= \tilde{s}_2(t+1) \oplus s_3^B(t) \\ &= \tilde{s}_2(t+1) \oplus s_2^B(t+1). \end{aligned} \quad (9)$$

The required number of phases for the two-way transmission can be reduced to only two phases as shown in Fig. 1 owing to the MIMO multiple access with network coding.

### III. PROTOTYPE HARDWARE AND DEMONSTRATION SYSTEM

#### A. Prototype hardware and demonstration system

In order to prove the realization of 2-way relay network, prototype hardware and a demonstration system are developed at 950MHz band. The developed prototype hardware is shown in Fig. 2. The prototype hardware consists of an array

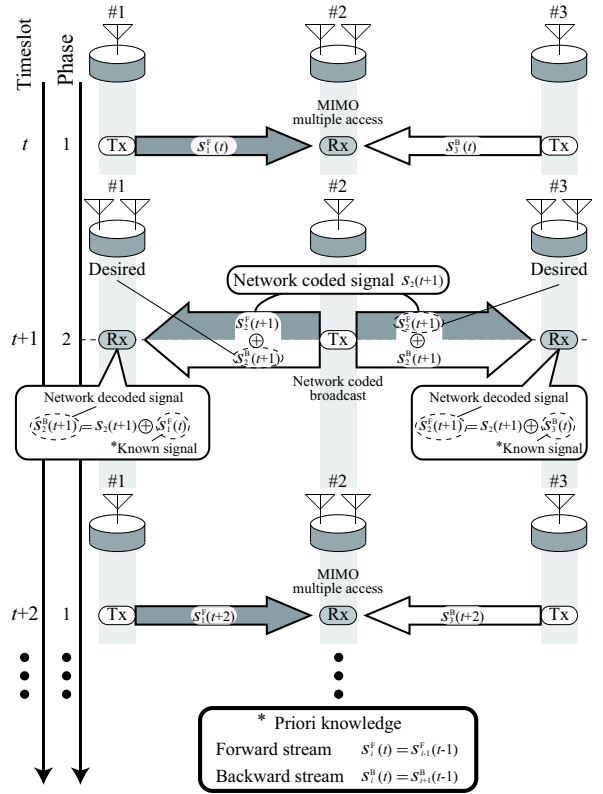

Fig. 1. TDD two-way multi-hop relay network using MIMO network coding.

antenna, an RF board, a baseband board, and a CPU. On the FPGA implemented on the baseband board, a real-time network synchronization scheme [6] is employed.

The demonstration scenario and system setting are described in Fig. 3. In this demonstration system, three prototype hardware are used to realize dual-hop 2-way relay network. The first node is the source of the forward stream as well as the destination of the backward stream. The third node is the destination of the forward stream as well as the source of the backward stream, and the second node relays these two-way streams. There is no mobility of the nodes, so that a fixed routing table is used in this demonstration system.

At the beginning, network synchronization is performed before starting communication mode. In the first phase of the communication mode, the first and third nodes transmit the forward and backward streams respectively. Then the second node receives the two transmitted signals by using MIMO multiple access. In the second phase, the network coded signal is broadcast from the second node to the first and third nodes. The first and third nodes obtain the desired signal by using network decoding. As a result, two-way streams are transmitted from the sources to the destinations with only two phases.

#### B. Transmission signal format

1) 950MHz band active low-power wireless system and OFDM signal format: Since Japanese 950MHz band is a spectrum sharing band with RFID, all systems must perform

carrier sense before transmission. In the Japanese radio law, the frequency bandwidth 4.8MHz (950.9-955.7MHz) is divided into 24 units (1 unit is 200kHz), and 3 units (600kHz) can be used at the same time. In the system, the 3 units compose a single channel. In the demonstration system, OFDM is applied in the 2-way relay network. OFDM which has tolerance for time dispersive multi-path fading is adopted as a modulation scheme. In this system, the sampling frequency of the OFDM modulation is configured as 5.0MHz. The transmit data are mapped into the desired channel by selecting partial subcarriers of the whole band, and the nulls are mapped into the other subcarriers as shown in Fig. 4. In Fig. 4, the transmit data are mapped into the first channel as an example. The spectrum and spectrogram of the RF output (the first channel) are shown in Fig. 5.

2) *Frame configuration*: Signal frame consists of preamble, PHY header, MAC header, and payload as shown in Fig. 6. The preamble is used for frame synchronization and channel estimation for both the purposes of OFDM demodulation and MIMO processing. The preambles are configured as orthogonal sequences for MIMO channel estimation by using four OFDM symbols. In this demonstration system, preamble sequences  $\mathbf{p}_1 = [p_1 \ p_2 \ p_3 \ p_4] = [P \ P \ P \ P]$  and  $\mathbf{p}_3 = [p_1 \ p_2 \ p_3 \ p_4] = [P \ -P \ P \ -P]$  are assigned for the first and third nodes respectively, where  $p_k$  is the  $k$ th preamble symbol. Since these preamble sequences are orthogonal, the second node can estimate the channel vectors between the first and second nodes and between the third and second nodes independently.

The PHY header consists of two parts of the forward and backward streams. The information of physical layer such as modulation scheme, code rate, and the length of the payload are included in the PHY header. The MAC header consists of the transmitter address (TA), the destination address of the forward stream (DAF), the destination address of the backward stream (DAB), and an information bit for network synchronization (SYNC). By using the TA and the routing table, each node finds whether the received signal should be decoded or not. Furthermore, from the DAF and DAB in the MAC header, each node finds the destination of the received signal. If the detected destination of the received signal is not the receive node, the node will relay the received signal to the next node based on its routing table. In the payload, the network coded signal of the forward and backward streams is stored.

### C. Network synchronization system

If OFDM is applied in the TDD two-way multi-hop relay network using MIMO network coding, the problem of inter-symbol-interference (ISI) and inter-carrier-interference (ICI) will occur, when an Rx node receives two signals from the adjacent nodes with some delay of arrival. At each Rx, the two signals from neighboring Tx access at the same time as shown in Fig. 3. When a block modulation such as OFDM is combined to multiple access system, all multiple access signals must arrive at the receiver at the same time. The arrival time

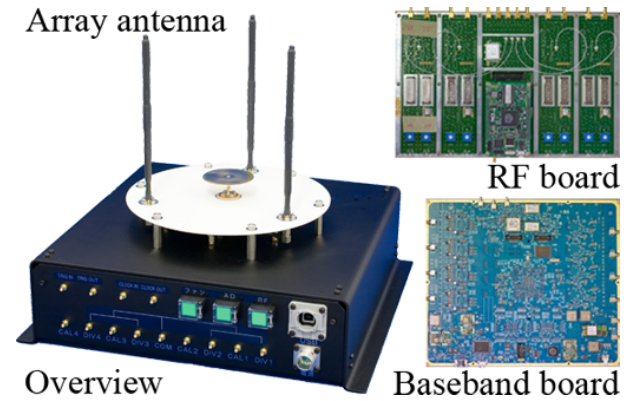

Fig. 2. Prototype hardware for TDD two-way multi-hop relay network.

mismatch between the multiple access signals causes the frame synchronization error of the block processing, and the ISI and ICI occur. Therefore, a network synchronization scheme is necessary. In the paper, the network synchronization scheme [6] in which conventional ranging scheme is extended to the two-way multi-hop relay network is implemented.

In the network synchronization scheme, the Tx/Rx timing of the master node (the first node) is fixed. The slave nodes are synchronized to the one-hop former node successively. The procedure of the network synchronization scheme is shown in Fig. 7.

- 1) The first node is a master node. The Tx and Rx timing and frame interval  $T$  are fixed. The first node transmits a training signal to the second node at a fixed Tx timing. The second node fixes the arrival timing of the training signal as its Rx timing.
- 2) The second node generates the temporary Tx timing after  $T/2$  from the fixed Rx timing, and training signal is transmitted to the first node at that timing. The first node measures the synchronization error  $d_{1,2}$  between the arrival time of the training signal and the fixed Rx timing of the first node.
- 3) The first node transmits the measured synchronization error  $d_{1,2}$  to the second node.
- 4) The second node adjusts the temporary Tx timing with  $d_{1,2}$  and fixes the Tx timing.
- 5) In the same way, the third node synchronizes to the second node. Since the first and third nodes transmit at the adjusted Tx timing, the signals simultaneously arrive at the second node.

In the hardware, Tx and Rx timing counters for the network synchronization are implemented in the FPGA.

### IV. MEASUREMENT IN REAL INDOOR ENVIRONMENT

In order to prove the realization and effectiveness of 2-way relay network, network throughput is measured in an indoor environment as shown in Fig. 8. The parameters of the measurement are shown in Table I. During the measurement, the doors of the experiment room #1 and #2 are closed, and nobody presents in the measurement environment to ensure a static condition. Each hardware is remotely controlled from

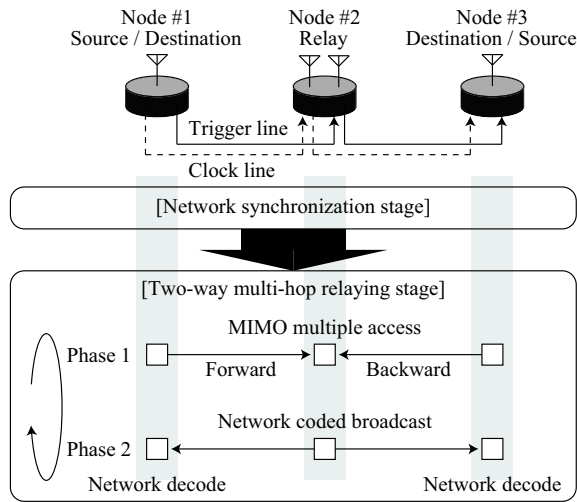

Fig. 3. Demonstration scenario and system setting with the prototype hardware.

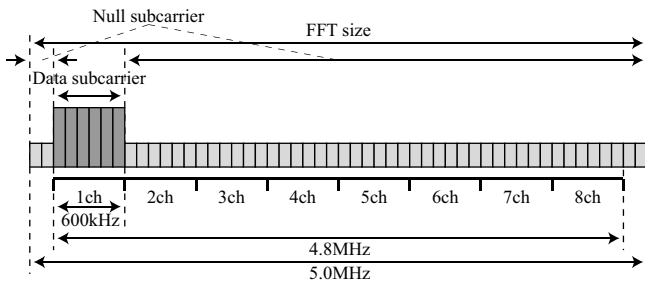

Fig. 4. OFDM signal generation scheme with null subcarriers.

another floor by a laptop PC via 2.4GHz WLAN. In order to average the effect of multi-path fading, antenna position is moved in a  $450 \times 450 \text{ mm}^2$  area by using a positioner as shown in Fig. 9, and 81 spatial samples are obtained. The transmit power of the source/destination node, the relay node, and the destination/source node are set to be the same. The

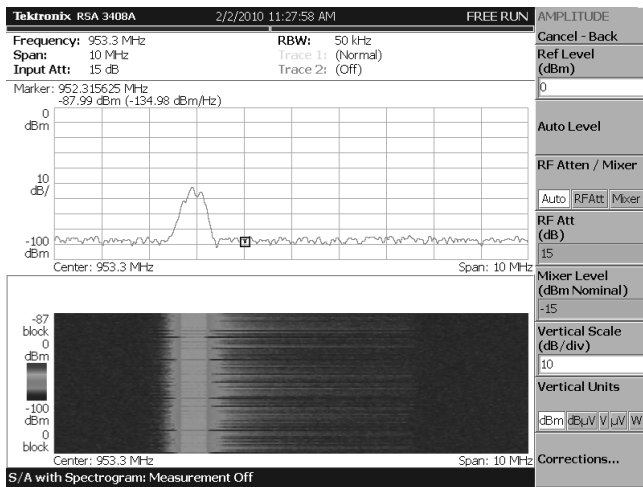

Fig. 5. Spectrum and spectrogram of RF output (first channel).

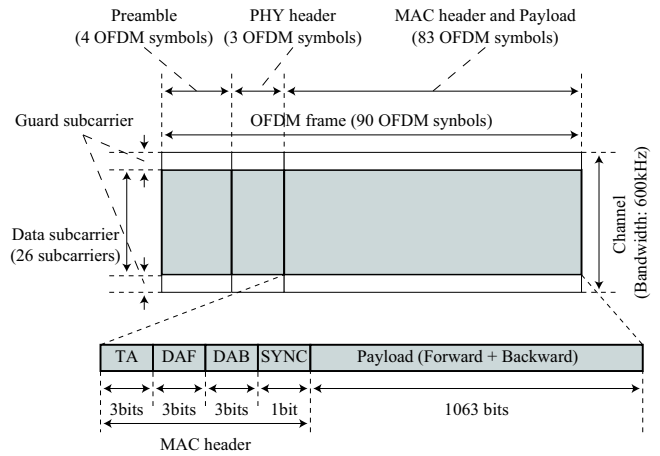

Fig. 6. Frame configuration.

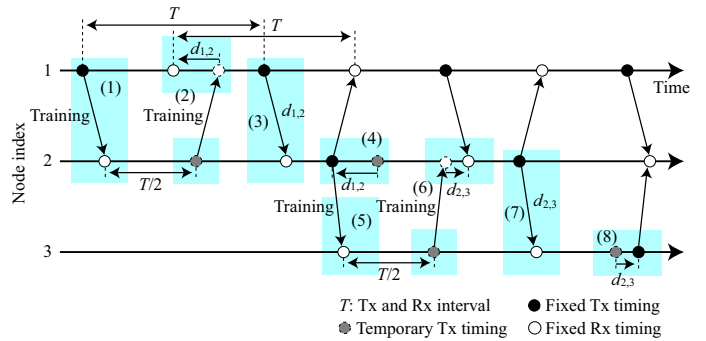

Fig. 7. Procedure of network synchronization scheme.

end-to-end SNR can be changed by adjusting the transmit power of each node. In the measurement, OFDM signal with  $1/8$  rate guard interval is used for the transmission. One packet consists of 90 OFDM symbols (including preamble, PHY and MAC header, and payload), and 1063 bits binary data is put into one packet with half rate convolutional coding and BPSK the modulation.

Figure 10 shows the measured network throughput in the environment. Red, green, and blue lines respectively show network throughputs of the 2-way relay network, the 1-way relay network, and direct link. The 1-way relay network is a simple TDD one-way multi-hop relay network with four TDD phases to transmit two-way streams in the dual-hop case. The horizontal axis indicates the average end-to-end SNR. In this measurement, the network throughput is calculated from the number of TDD phases and the successfully received bits in one TDD phase. In Fig. 10, the network throughput of the 1-way relay network is larger than that of the direct link when the average end-to-end SNR is lower than 2dB. This is owing to the benefit of the introduction of the relay node. However, when the average end-to-end SNR is high, the direct link is more effective than the 1-way relay network, because the 1-way relay network needs twice TDD phases for two-way transmission in comparison with the direct link.

On the other hand, the network throughput of the 2-way

TABLE I  
PARAMETERS OF MEASUREMENT.

FFT points $N$	256
Sampling frequency $F_s$	5.0MHz
Guard interval (GI) rate $G$	1/8
One symbol duration (including GI)	51.2 us (57.6 us)
Center frequency	951.2 MHz
Channel bandwidth	600 kHz
Number of subcarriers per channel	26
Number of symbol in one frame $S$	90
Modulation	BPSK
Coding rate	1/2 (Convolutional code)
Number of bits in one packet $B$	1063 bits

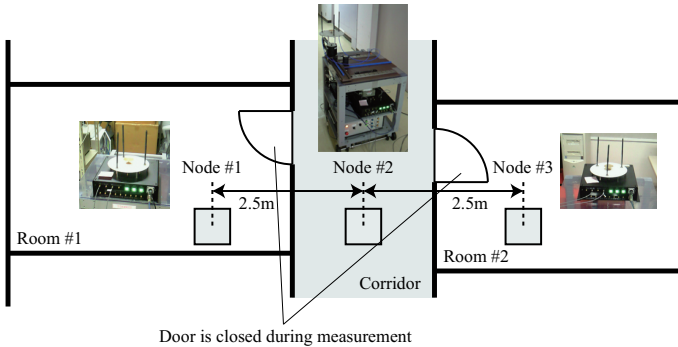

Fig. 8. Node arrangement in experiment rooms and corridor.

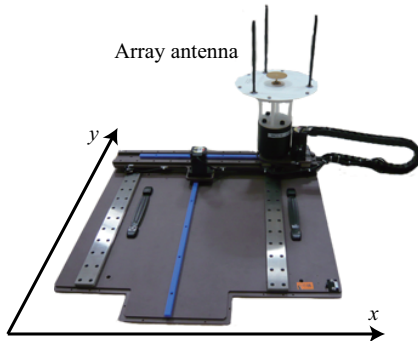

Fig. 9. Positioner for 2-D scan.

relay network is around as twice as that of the 1-way relay network. Furthermore, the network throughput of the 2-way relay network is larger than that of the direct link at all average end-to-end SNR. This is owing to the benefit of relaying and MIMO network coding.

From these results, the realization and effectiveness of the 2-way relay network are proved in the real indoor environment.

## V. CONCLUSION

In this paper, prototype hardwares and a demonstration system were developed at 950MHz band for the proof of the 2-way relay networks. In the demonstration system using the prototype hardware, the MIMO network coding and network synchronization scheme for TDD two-way multi-hop relay networks were implemented. Network throughput was measured in an indoor environment to prove the realization of the 2-

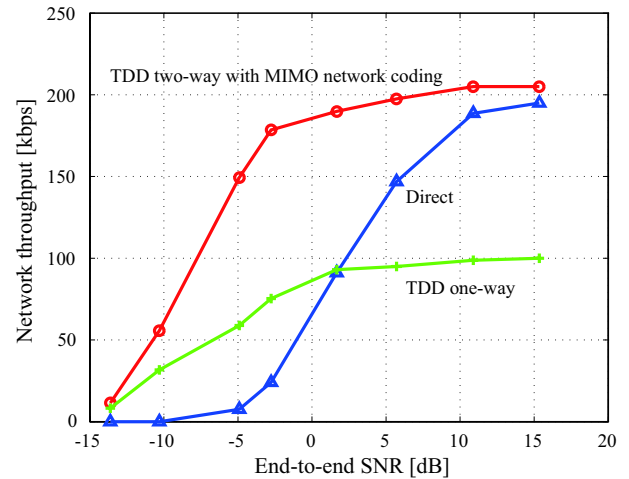

Fig. 10. Throughput performance of 3-node relay network.

way relay network. The network throughput of the 2-way relay network is as twice as that of the 1-way relay network, and also higher than that of the direct link at all average end-to-end SNR. This is owing to the benefit of MIMO network coding. From these results, the realization and effectiveness of the 2-way relay network can be proved in the real indoor environment.

## REFERENCES

- [1] I. F. Akyildiz, X. Wang, "A survey on wireless mesh networks," *IEEE Commun. Mag.*, vol. 43, no. 9, pp. 523–530, Sept., 2005.
- [2] R. Ahlswede, N. Cai, S. Y. R. Li, R. W. Yeung, "Network information flow," *IEEE Trans. Inf. Theory*, vol. 46, pp. 1204–1216, July Sept., 2000.
- [3] P. Popovski, H. Yomo, "Bi-directional amplification of throughput in a wireless multi-hop network," *Procs. of IEEE VTC2006-Spring*, vol. 2, pp. 588–593 May, 2006
- [4] S. Katti, H. Rahul, W. Hu, D. Katabi, M. Medard, J. Crowcroft, "Xors in the air: Practical wireless network coding," *Procs. of ACM SIGCOMM'06*, pp. 243–254, June, 2006.
- [5] F. Ono, K. Sakaguchi, "STBC MIMO Network Coding for Bi-directional Multi-Hop Relay Networks," *IEICE Trans. Commun.*, vol. E92-B, no. 12, pp. 3676–3682, Dec., 2009.
- [6] K. Mizutani, K. Sakaguchi, K. Araki, "Network Synchronization for Two-way Multi-hop Relay Networks with Block Modulation," *Procs. of IEEE VTC2010 Spring*, pp. 1–5, May, 2010.