

# Flexible Wireless System: Unified Wireless Platform for a Wide Variety of Wireless Systems

Doohwan Lee, Takayuki Yamada, Hiroyuki Shiba, Yo Yamaguchi, Takana Kaho, and Kazuhiro Uehara  
NTT Network Innovation Laboratories, NTT Corporation  
1-1 Hikari-no-oka, Yokosuka-shi, Kanagawa, Japan  
lee.doohwan@lab.ntt.co.jp

**Abstract**—A flexible wireless system (FWS) is a unified wireless platform which simultaneously deals with various types of wireless signals. The FWS consists of flexible access points (distributed remote stations) and flexible signal processing unit (central station). Various types of radio wave data is received at flexible access points and transmitted to the flexible signal processing unit through the wired access line. In particular, recently developed compressed sensing technology is applied as a radio wave data compression method. This paper introduces the prototype of the flexible access system.

**Keywords**—component; flexible wireless system, compressed sensing, software defined radio

## I. INTRODUCTION

Rapid developments and changes of wireless radio environments require a unified platform which can flexibly deal with various wireless radio systems. To satisfy this requirement, we have proposed a flexible wireless system (FWS) [1]. Figure 1 illustrates the concept of the FWS. Various wireless signals are simultaneously received by flexible access points. Flexible access points have the capability of receiving a wide variety of wireless signals from several hundred megahertz to several gigahertz. The received radio wave data is transferred to the flexible signal processing unit through the broadband wired access line. The flexible signal processing unit performs multiple types of signal analysis by software exploiting software defined radio and cognitive radio technologies [2].

The FWS consists of three key technologies: 1) RF technology for reception and transmission over wide frequency bands, 2) data compression technology between flexible access points and flexible signal processing unit, and 3) signal processing technology for extracting the desired signal from overlapped and interfered signals.

RF and signal processing technologies were implemented by the first generation FWS prototype [1]. The broadband low noise amplifier with wide dynamic range [3] and signal separation method for overlapped signals were implemented. The experiment results of the first generation FWS prototype confirmed the system's practicality. The front-end ICs for receiver yielded the signal reception capability from 300 MHz to 3 GHz frequency bands signals. The signal processing unit also yielded the capability of demodulating the overlapped signal by software with reduced CPU processing load. These

RF and signal processing technologies are further expanded to [4] and [5], respectively.

We have recently developed the second generation FWS prototype. Data compression technology between flexible access points and flexible signal processing unit is mainly concerned in the second generation FWS prototype. To overcome the huge bandwidth necessity for transferring the radio wave data, recently developed compressed sensing technology [6-8] is applied as a data compression method. Moreover, to achieve the enhanced performance, our previous research works [9-11] are also implemented. [9] proposed the combined Nyquist and compressed sampling method to apply compressed sensing technology for multiple signals with different priorities. [10] suggested the weighted compressed measurement matrix generation method for utilizing the prior information. [11] developed the processing burden reduction method using averaged compressed sensing.

This paper introduces the second generation FWS prototype. The remainder of this paper is organized as follows: Section II introduced the details of the prototype of FWS. Section III describes the context of the demonstration and shows the experiment results, and Section IV summarizes this paper.

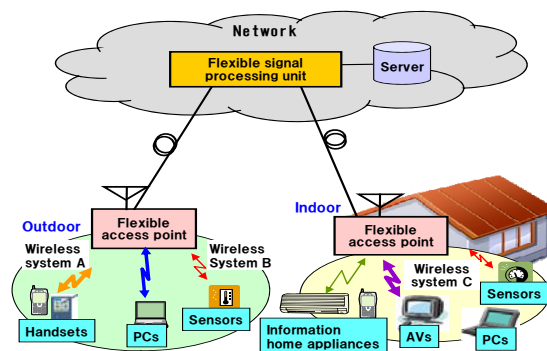

Fig.1 Concept of a flexible wireless system.

## II. PROTOTYPE OF A FLEXIBLE WIRELESS SYSTEM

### A. Wireless Environment

To make the virtual environment in which various types of wireless signals exist, we used various types of active RFIDs. Since protocols and data rates are different from each other, multiple types of RFIDs can be a proper model for the FWS. The frequency bands of RFIDs are 300 MHz, 430 MHz, 950

MHZ, and 2.45 GHz. Protocol and dynamic range of each RFID are diverse.

### B. Architecture of Prototype

Figure 2 and Table 1 show the architecture of the prototype and the specification, respectively. A flexible access point consists of RF front-end, ADC, DAC, compressed sensing unit, and IP packetizing (unpacketizing) unit. The wired access line is implemented by 10 Gbit/s optical fiber. A flexible signal processing unit consists of protocol-free baseband signal processing unit, compressed sensing reconstruction unit, and IP packetizing (unpacketizing) unit.

For the downlink signal processing, the received RF wireless signals at a flexible access point are downconverted into IF band after broadband low noise RF operation. These downconverted signals are compressed using compressed sensing technology after the analog-to-digital conversion. Then, the compressed signals are transferred to the flexible signal processing unit through the 10 Gbit/s optical fiber after the IP packetizing.

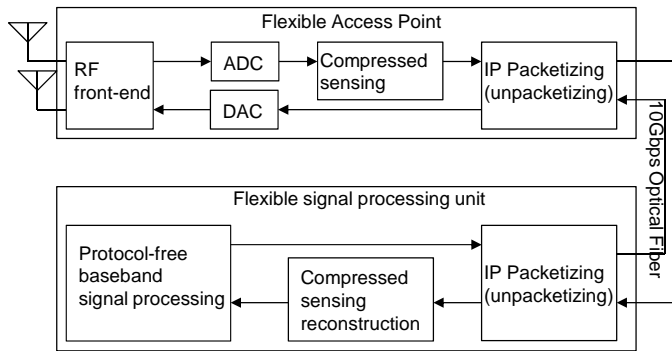

Fig.2 Architecture of the Prototype.

TABLE I. SPECIFICATIONS OF PROTOTYPE

Flexible access point RF receiver	RF	280 ~322 MHz 2.4 ~ 2.442 GHz
	IF	1 ~ 43 MHz
	Input level	-80 ~ -41dBm
Flexible access point RF transmitter	RF	280 ~322 MHz
	IF	1 ~ 43 MHz
	Output level	under 35 $\mu$ V/m
ADC / DAC	Channel number	2 channels
	Bandwidth	1 ~ 43 MHz
	Quantization	16 bits
	Sampling rate	100 Msps
Access Line	Interface	10Gbit/s optical fiber
Flexible signal processing unit	CPU	2.66 GHz Zeon (Quad core) X 2
	Memory	8 GB
	OS	Windows server 2003 R2 standard edition

Subsequently, the transferred compressed signals are reconstructed by compressed sensing reconstruction algorithm such as L1-minimization after the IP unpacketing. Finally, the baseband signal processing is conducted using the reconstructed signals by software. The uplink signal processing is conducted by opposite order except the compressed sensing

and its reconstruction process. The appearance of the prototype is shown in Fig. 3. All signal processing is conducted by software except RF operation, ADC, and DAC.

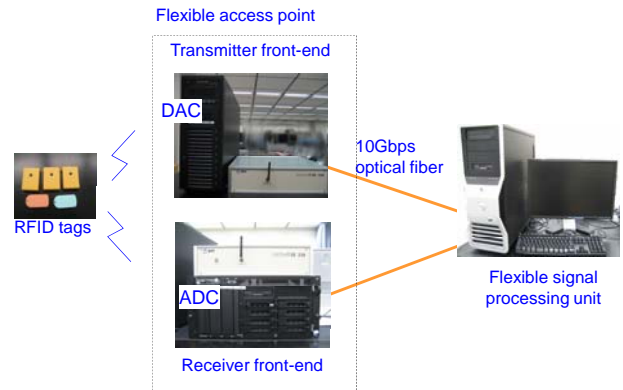

Fig.3 Appearance of the Prototype.

### C. Architecture of RF front-end

Figure 3 shows the architecture of RF front-end. Two antennas receive 300 MHz band and 2.4 GHz band signals, respectively. Those signals are downconverted and merged at 1 to 43 MHz IF band. The wideband LNA yields superior characteristics of which  $S_{21}$  parameter is below 20 dBm over 0.2 to 6 GHz band. This superior characteristic enables wideband and low-noise RF operation. Although this prototype deals with two frequency bands signals for the basic validation, our current work includes expanding the number of the frequency bands [4].

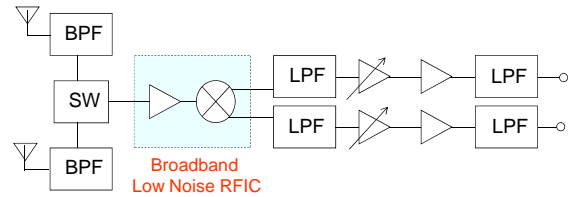

Fig.3 Architecture of RF front-end.

### D. Radio Wave Data Compression by Compressed Sensing

#### D.1 Compressed Sensing

For the radio wave data compression, compressed sensing technology is applied. Compressed sensing is a new method for solving ill-posed inverse problem utilizing the sparsity of the original data. Figure 4 [12] is the most frequently referred example of compressed sensing. Left figure is time domain dense signal. Marked points indicate randomly sampled data. Right figure shows reconstructed signal in the frequency domain using only randomly sampled data. These figures verify that frequency domain sparse signal can be reconstructed from time domain sub-Nyquist rate random sampling.

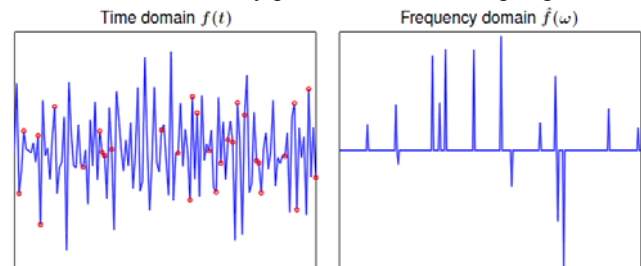

Fig. 4 Compressed sensing example of the freq. domain sparse signal [12].

Figure 5 shows a conceptual example of finding the sparse solution using L1-norm minimization. With respect to compressed sensing, finding the sparse solution means the reconstruction of the original signal from the compressed data. L1-norm minimization method finds the solution from the infinite solution plane by adjusting (optimizing). As confirmed from the figure, the solution obtained by adjusting L1-ball is inherently sparse L1-ball. On the other hand, L2-norm minimization method (minimizing mean square error) does not yield the sparse solution because the point where L2-ball reach the solution plane is usually non sparse point. This explains why and how L1-norm minimization is used for compressed sensing. As frequently mentioned in the literature, the time-frequency-space resources are sparsely utilized. Therefore, compressed sensing can enable the large-scale data processing using sub-Nyquist rate information.

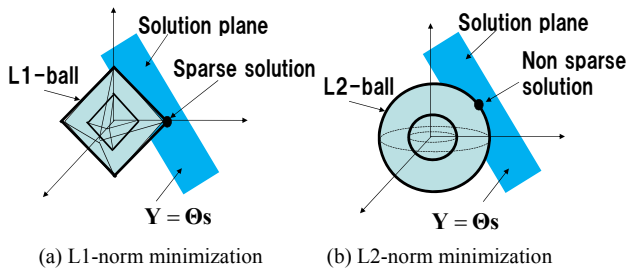

Fig. 5 Graphical illustration of L1-norm minimization and L2-norm minimization method.

There also exist other approaches to the reconstruction of compressed sensing such as an orthogonal matching pursuit algorithm, which uses a greedy iterative algorithm [14], or gradient projection method for sparse recovery (GPSR), which enhances the processing speed for reconstruction process [15]. L1-minimization method [13] and GPSR method are implemented in our prototype as a reconstruction algorithm.

### D.2 Averaged Compressed Sensing

To achieve the enhanced performance, our previous research works [9-11] are also implemented. In particular, processing burden reduction method using averaged compressed sensing [11] is mainly concerned for the real-time operation.

Figure 5 shows an example of the averaged compressed sensing. Original signal is transformed into the frequency domain by FFT. Then, the absolute values of Fourier coefficients are averaged over a period. The number of measurements is reduced as much as the ratio between the frame length and the average period. Subsequently, compressed measurement is conducted with averaged absolute values of Fourier coefficients. These measured data is transferred through wired access line and reconstructed at the flexible signal processing unit. By applying this method, the number of reconstruction is also reduced as much as the ratio between the frame length and the average period.

### E. Signal Processing of Flexible Signal Processing Unit

Figure 6 shows the concept of signal separation and restoration for spectrally overlapped signal at flexible signal processing unit. The frequency analysis is conducted by the Short Time Fourier Transform to extract amplitude and phase values at each center frequency of overlapped signals. Using these values enables signals from received radio wave data to be

separated and reconstructed. Detailed explanation on signal processing method and its enhanced version are described in [1] and [5], respectively.

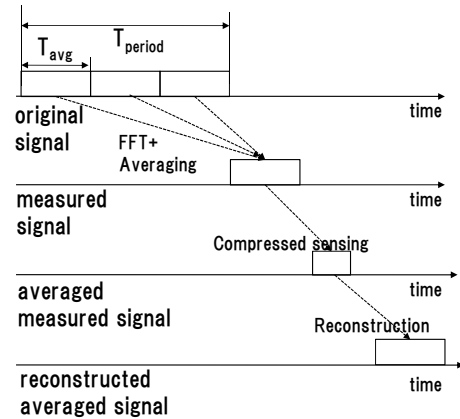

Fig.5 Example of the averaged compressed sensing.

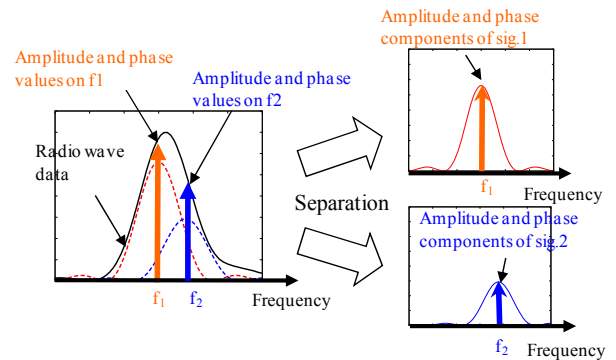

Fig.6 Signal Separation and restoration at flexible signal processing unit

## III. DEMONSTRATION AND EXPERIMENT RESULTS

This section introduces the context of demonstration and shows experiment results.

All operations are controlled by software at the flexible signal processing unit. Figure 7 shows the user interface of flexible signal processing unit. It is implemented using Visual C++ and run on Window OS. All of parameter settings are done by control window at flexible signal processing unit. Control parameters necessary for RF and compressed sensing operations such as sampling rate, initial seed for random measurement matrix generation, period of average, and frame length are transferred from the flexible signal processing unit to the flexible access points. If necessary, updated control parameters are transferred as well.

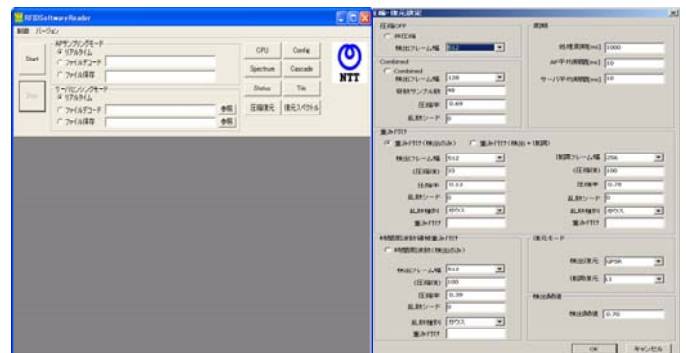

Fig. 7 User interface of flexible signal processing unit.

Some important parameter settings for the demonstration are given in Table 2. The whole bandwidth 10 MHz is sampled at 20 Msps at flexible access point. Sampled data is compressed by averaged compressed sensing and transferred to flexible signal processing unit. The data rate of RFID is varied from 9.6 Kbit/s to 36.4 Kbit/s. Due to the spectral leakage, its channel bandwidth occupies up to 300 KHz. The frequency domain sparsity is 0.3 (300 KHz among 10 MHz). Signal duration of RFIDs varies from 5 ms to 20 ms, and their period is 1s. Therefore, time domain sparsity is 0.005 to 0.02. Average period is set from 1 ms to 10 ms. Of course, tradeoff between processing burden and time resolution exist depends on the length of average period. Using above parameter settings, 0.001 to 0.0001 compression rate is obtained guaranteeing the perfect signal detection performance.

TABLE II. PARAMETERS FOR DEMONSTRATION

Bandwidth	10 MHz
Sampling rate	20 Msps
Quantization	16 bits (I/Q 32 bits)
Channel Bandwidth of RFID	~ 300 KHz
Modulation of RFID	FSK
Data rate of RFID	9.6 Kbit/s, 19.2 Kbit/s, 36.4 Kbit/s
Period of RFID	1 s
Signal duration of RFID	5ms, 10ms, 20 ms
Average Period	1ms - 10 ms
Compression rate	0.0001 ~ 0.001

Figure 8 shows snapshots of operation of prototype. Figure 8 (a) shows the law data when compressed sensing is not applied. For the transfer the 10 MHz radio wave without compression, 640 Mbit/s transfer rate is necessary. Figure 8 (b) shows the data transfer rate when compressed sensing is applied. Almost compression rate of 0.001 is achieved in this example. Figure 8(c) shows the reconstructed signal with compressed data. It is confirmed that three RFID signals are clearly detected. Note that RFID signals are actually not overlapped in the time domain in this example. The reason what three RFID signals seems to exist together in Figure 8(c) is due to the update time of display, which is not related with compression or detection performance.

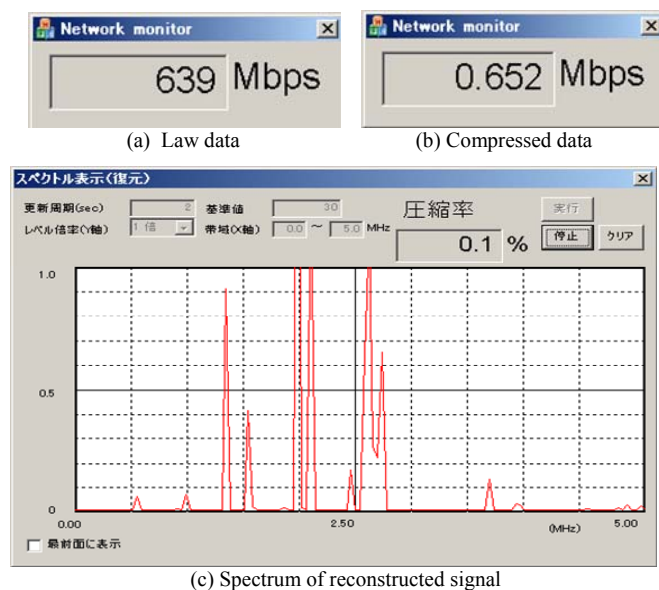

Fig. 8 Snapshots of transmitted data rate and reconstructed signal.

Figure 9 shows the probability of detection success rate when the number of RFID is one (38.4Kbit/s) and average period is 10 ms. Simulation result is obtained from Matlab simulation using received data at flexible access point. Experiment result is obtained from the output of prototype. Two curves in Fig. 9 shows the similar trend except that the simulation performance is slightly better than that of experiment. This slight difference comes from 1) precision difference 2) diversity of random measurement matrix. Matlab simulation is not limited to 16 bit quantization and its random measurement matrix is updated at every run of simulation. Although this slight difference, it can be stated that the experiment result yields great compression performance. Compression rate of 0.00015 guarantees the perfect detection performance in this case.

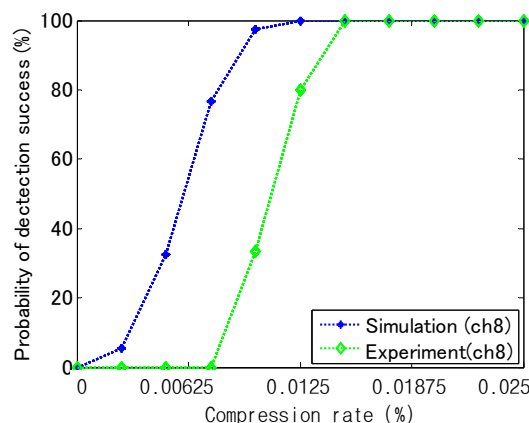

Fig. 9 Probability of detection success rate (Number of RFID:1, Data rate of RFID: 38.4Kbit/s, average period: 10ms).

#### IV. SUMMARY

This paper introduced the FWS prototype which is updated from our previous prototype. For the realization of the FWS, RF and signal processing technologies were implemented in our previous prototype. It confirmed the system's practicality. Our new prototype mainly implements the data compression technology utilizing recently developed compressed sensing. Moreover, averaged compressed sensing is implemented to further reduce the processing burden. Experiment results shows that the real time signal detection can be conducted using RFID signals. The demonstration will show the operation of our prototype using RFID signals.

#### REFERENCES

- [1] H. Shiba, Y. Yamaguchi, K. Akabane, T. Yamada, and K. Uehara, "A flexible wireless system supporting for a wide variety of wireless systems," IEICE Technical Report, SR2010-37, Jul. 2010.
- [2] K. Uehara, K. Araki, and M. Umehira, "Trends in Research and Development of Software Defined Radio," NTT Technical Review, Vol. 1, No. 4, pp. 10-14, 2003.
- [3] M. Kawashima, Y. Yamaguchi, K. Nishikawa, and K. Uehara, "Broadband low noise amplifier with high linearity for software-defined radios," Proc. European Microwave Integrated Circuit Conference (EuMIC) 2007, pp. 243 - 246, Oct. 2007.
- [4] T. Kaho, Y. Yamaguchi, H. Shiba, D. Lee, T. Yamada, M. Kawashima, and K. Uehara, "Proposal of a wide-band and high dynamic range receiver for flexible wireless systems," IEICE Tech. Report MW2010-61, Jul. 2010.

- [5] T. Yamada, D. Lee, H. Shiba, Y. Yamaguchi, and K. Uehara, "Signal Separation and Reconstruction Method for Simultaneously Received Multi-System Signals in a Unified Wireless System," Proc. 6th International Conference on Cognitive Radio Oriented Wireless Networks, May, 2011.
- [6] E. Candes and M. Wakin, "An introduction to compressive sampling," IEEE Signal Process Mag., vol. 25, no. 2, pp.21-30, Mar, 2008.
- [7] D. Donoho, "Compressed sensing," IEEE Trans. Inf. Theory, vol. 52, no. 4, pp.1289-1306, Apr. 2006.
- [8] E. J. Candès and T. Tao, "Decoding by Linear Programming," IEEE Trans. Inf. Theory, Vol. 51, No. 12, pp. 4203–4215, Dec. 2005.
- [9] D. Lee, T. Yamada, H. Shiba, Y. Yamaguchi, and K. Uehara, "Combined Nyquist and Compressed Sampling Method for the Wireless Multiband Receiver," IEICE Trans. Commun., Vol. E93-B, No. 12, Dec. 2010.
- [10] D. Lee, T. Yamada, H. Shiba, Y. Yamaguchi, and K. Uehara, "Time-frequency Domain Weighted Measurement Matrix Generation Method for Compressed Sensing," IEICE Society Conference, Sep. 2010.
- [11] D. Lee, T. Yamada, H. Shiba, Y. Yamaguchi, and K. Uehara, "Processing burden reduction of a large-scale data compression by employing averaged compressed sensing," IEICE Tech. Report SR2010-69, Jan. 2011.
- [12] R. Baraniuk, J. Romberg, and M. Wakin, "Tutorial on compressive sensing," 2008 Information theory and application workshop, [Online]. Available: <http://www.ece.rice.edu/~richb/talks/cs-tutorial-ITA-feb08-complete.pdf>.
- [13] E. J. Candès and J. Romberg, "l1-magic: Recovery of Sparse Signals via Convex Programming," available online at [www.l1-magic.org](http://www.l1-magic.org). Oct. 2005.
- [14] J. A. Tropp and A. C. Gilbert, "Signal Recovery from Random Measurement via Orthogonal Matching Pursuit," IEEE Trans. Inf. Theory, Vol. 53, No. 12, pp. 4655–4666, Dec. 2007.
- [15] M. Figueiredo, R. Nowak, and S. Wright, "Gradient Projection for Sparse Reconstruction: Application to Compressed Sensing and Other Inverse Problem," IEEE Selected Topics in Signal Processing, Vol. 1, No. 4, pp. 586-597, Dec. 2007.