

Analysis of Foreign Exchange Using Neural Network and Adaptive Neuro Fuzzy Inference System (ANFIS)

Yulius Eka Agung Seputra¹, Ahmad Rodoni², Meirinaldi³
{yulius.eka@gmail.com¹, ahmad.rodoni@uinjkt.ac.id², usu_mey@yahoo.co.id³}

Student of Doctoral Program in Economics, Borobudur University¹
Borobudur University²³

Abstract. Foreign Exchange (FOREX) is the exchanging of one money against another. FOREX rates are impacted by many related monetary, political and mental variables and subsequently anticipating it is a difficult errand. A few techniques to foresee the FOREX rate incorporate measurable examination, time series investigation, fluffy frameworks, brain organizations, and mixture frameworks. These techniques experience the ill effects of the issue of precisely foreseeing the trade. An Artificial Neural Network (ANN) and a cross breed Neuro-Fuzzy framework (ANFIS) are proposed to foresee the future pace of the FOREX market because can combine fundamental and technical FOREX Data. The independent variables studied in this study were the exchange rates of China, Japan, Europe, Gold and Crude Oil to analyze the Rupiah exchange rate dependent variable. For the analysis, USDIDR swapping scale from the forex market is utilized. Mean Square Error (MSE) and Mean Absolute Error (MAE) are utilized as execution pointers. ANFIS model accomplished a MSE of 0.02 and a MAE of 0.00792 during the preparing and testing stage.

Keywords: Technical Analysis; Fundamental Analysis; investment decision making; Trading Transactions; Forex; Forex Trading

1 Introduction

Foreign Exchange (FOREX) is a sort of exchanging of the country's money against the monetary standards of different nations and cash sets are called sets, unfamiliar trade exchanges including significant cash markets all over the planet for 24 hours constantly. Given the degree of advancement of liquidity and the speed with which money value developments are extremely high, unfamiliar trade exchanging has turned into an option for a financial backer on the grounds that the benefits to acquired surpass exchange general. Because of the fast cost developments, foreign trade exchanging additionally conveys an extremely high gamble.[1]

With risk, there is likewise a chance for benefit. Thusly, a merchant is expected to have great specialized and principal examination abilities to have the option to harvest enormous benefits from exchanging these monetary forms. Value expectations are utilized to help merchants in settling on choices whether they should sell or purchase while in the unfamiliar trade market. Specialized examination is utilized to foresee the cost available will rise or will fall in view of the cost edge (support) and the cost edge (opposition) in light of the Moving Average.[2]

The Forex dataset is a public dataset as time series information which is downloaded in the investing.com and mt4 application on the fbs server, while to process fbs information it is important to preprocess the gathering of information to standardize it with the goal that it is not difficult to handle the proposed technique.

The Autoregressive Integrated Moving Average (ARIMA) model is a model that totally disregard the free factors in making gauges. ARIMA utilizes the at various times upsides of the reliant variable to create exact momentary estimating. ARIMA is appropriate if the perceptions from time series (time series) are genuinely connected with one another (dependent).[2]

Adaptive Neuro Fuzzy Inference System (ANFIS) To foresee FOREX, an autoregressive model is required that can dissect transient information and long-haul information and can adjust different sorts of information with various time-frames, in this study utilized Forex information with long haul which is central information and momentary information which is specialized information. (ANFIS) can be utilized for expectation and anticipating with the standard ANFIS design of five layers. ANFIS is a joined strategy between fluffly rationale and Artificial Neural Networks (ANN).

The blend of the two strategies is supposed to be a mixture framework. ANFIS likewise has a few types of hub layers in view of a fluffly induction framework. Notwithstanding, the fluffly rationale technique enjoys benefits in demonstrating the subjective viewpoints acquired from human information and the dynamic cycle by applying a standard base. While the ANN strategy can work in view of past recorded information and can foresee future occasions in light of the inputted information.[3]

2 Research Methods

2.1 Foreign Exchange (FOREX) Prediction

There are a few customary forex loan fee hypothesis models, for example, financing cost equality, buys, and so on Equilibrium of buying power equality and worldwide settlement for unfamiliar trade determining. It is extremely challenging to anticipate after the presentation of the drifting swapping scale framework. Autoregressive Moving Average (ARMA) is the most proper for models, for example, consistent trade rates and autoregressive restrictive heterogeneous differences (ARCH) and summed up autoregressive contingent heterogeneous fluctuation (GARCH).[4]

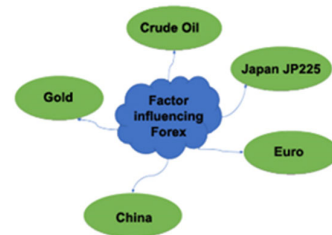

Fig 1. Factor Influencing Forex

There are a few non-straight models Developed to give preferable outcomes over ARMA, ARCH and GARCH For dynamic trade rates. A few nonlinear models incorporate counterfeit brain organizations (ANN), hereditary calculations (GA), and many different models offer

higher exactness contrasted with different models. The loan cost is one of the central point that impacts the Forex rate, it is the pace of revenue charge by the country for any monetary exchange. [5]

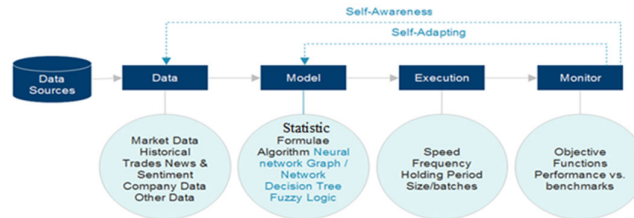

Fig 2. Forex Analysis Model

2.2 Adaptive Neuro Fuzzy Inference System (ANFIS)

ANFIS is an organization structure in which a bunch of altered boundaries decides the general info yield conduct. One of the brain network structures is the multi-facet perceptron (MLP). The ANFIS hub can conjecture datasets in monetary time series. ANFIS consolidates fluffy rationale and brain organizations. ANFIS handles arbitrary information that join the Least-Squares Estimator (LSE) and Back-Propagation (EBP) techniques. The utilization of ANFIS is finished by entering learning information into fluffy rationale and searching for the worth with the littlest blunder rate. For additional insights regarding how the enrollment work functions, see the Fig.3

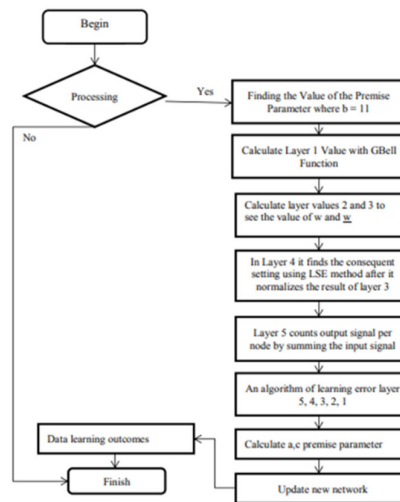

Fig 3. ANFIS Flowchart

In this cycle, the info was determined fluffy participation capacity to change the customary arrangement of information (fresh) partially. Participation work utilized is the Bell-type. The participation work has two boundaries to be specific mean and fluctuation boundaries. The boundary in the ANFIS technique is called as reason boundary. In the second and third layer,

surmising motor cycle (Fuzzy derivation framework) indicated the fluffy rule for the further computation process. In this interaction, in light of the fact that the ANFIS framework utilized was one info, then there was no estimation. The result hub of this layer was equivalent to the result layer hub 1.

In layer three was standardized every vertex showed the level of actuation standardized. In layer four the defuzzification cycle played out the estimation of changing the fluffy outcomes into the fresh result structure. In this layer, the LSA computation was performed to acquire the accompanying boundary values. In layer five an outline cycle of two results was performed on layer 4.[6].

In ANFIS the fluffy framework was situated on layers 1(Learning), Layers 2 (Fuzzyfication), Layers 3(Fuzzy Inference System) and Layers 4 (Fuzzy Test with Takagi Sugeno Kang). The fluffy framework was the secret hub determinant of the brain network framework.[7]

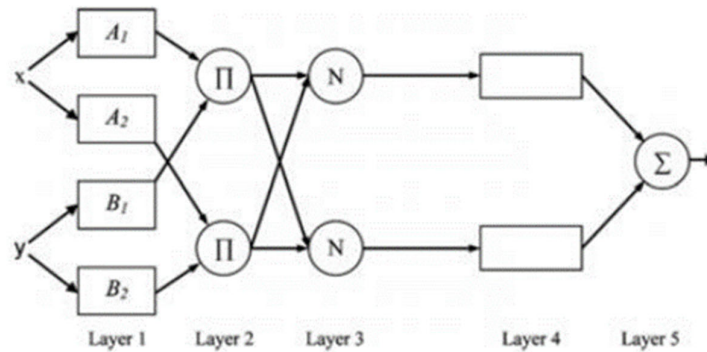

Fig 4. ANFIS

The ANFIS model, including the autoregressive model, is a mix of fluffy derivation framework components depicted in the brain network design. This Fuzzy Inference System changes over quantitative mathematical information into subjective semantic information by weighting and taking away specific constants. The fluffy surmising framework utilized is the main request Takagi-Sugeno Kang (TSK) model fluffy derivation framework because of contemplations of straightforwardness and computational simplicity. Simultaneously. [8].

ANFIS utilizes a brain organization, while the arrangement utilizes fluffy rationale. The ANFIS technique can be given contribution to the type of long haul subjective and quantitative information in learning.

2.3 Forex Data

This study utilizes the reliant variable of Indonesia's unfamiliar conversion scale against the dollar and the autonomous variable of the cash swapping scale of China, Japan, Europe, Gold and Crude Oil in unfamiliar trade exchanging from 1990-2021.

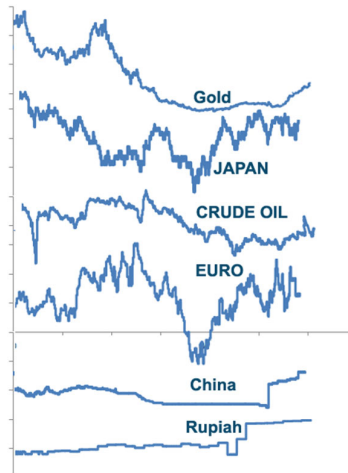

Fig 5. Forex Data

3 Results and Discussion

China Forex is exceptionally corresponded with Forex rate. The country with exorbitant financing cost will cause serious effect on the nearby business of the country. The country with higher financing cost diminishes the buy force of shoppers and furthermore individuals who intend to take advances needs to pay exorbitant premium which will at last decrease the financial backers. Japan Forex is exceptionally corresponded with Forex rate. The country with exorbitant financing cost will cause serious effect on the nearby business of the country. The country with higher financing cost diminishes the buy force of shoppers and furthermore individuals who intend to take advances needs to pay exorbitant premium which will at last decrease the financial backers.

Europe Forex is exceptionally corresponded with Forex rate. The country with exorbitant financing cost will cause serious effect on the nearby business of the country. The country with higher financing cost diminishes the buy force of purchasers and furthermore individuals who intend to take advances needs to pay exorbitant premium which will eventually decrease the financial backers.

The Inflation rate decides the award of the item in a nation and it basically relies upon the commodity strength of the country. The country with low expansion rate will draw in the financial backers to put more in these nations thusly, expansion rate plays the significant part in the valuation of the unfamiliar cash swapping scale. Expansion is a significant component that influences the swapping scale in a country. The event of expansion should be visible to breaking down the personality of the conversion scale of gold and oil.

Financial backers will normally purchase up gold to safeguard the worth of their abundance when expansion increments and spreads in different spots. Unrefined petroleum is a hazardous item where cost changes happen in view of the interest and supply component which is fundamental for a nation's economy, replaces in oil costs can influence the expansion rate. One

might say that replaces in oil costs are expansion assumptions later on, while gold costs are an impression of financial backers' responses when expansion extends.[9]

Table 1. The factors that influence the FOREX

Variable	Mean Square Error (MSE)	Mean Prediction Error (MPE)	Adjusted R Square	Durbin Watson
Rupiah-Dolar	0,0863	0,0084	0,895616	1,877200
China - Dolar	0,0428	0,0025	0,797356	2,003753
Japan - Dolar	0,1142	0,0187	0,817880	2,037140
Euro - Dolar	0,0653	0,0081	0,839011	1,736211
Gold	0,0563	0,0045	0,793241	1,682757
Crude Oil	0,0796	0,0105	0,810651	1,896902

Table 1 shows the factors that influence the FOREX conversion standard and shows that the China-Indonesia and Europe-Indonesia relations have lower MSE and MPE values than different factors, demonstrating that there is close collaboration between Indonesia - China and Europe. Relations among Japan and Indonesia have little MSE and MPE values, which show that there is still great participation in exchange, product and import to Japan, albeit not quite so large as China and Europe.

Table 2. The factors that influence the rupiah-dollar FOREX

Dependent Variable	Independent Variable	Mean Square Error (MSE)	Mean Prediction Error (MPE)	Adjusted R Square	Durbin Watson
Rupiah-Dolar	China , Japan, Europe, Gold, Crude Oil	0,0863	0,0084	0,895616	1,877200

Table 2 shows the factors that influence the rupiah-dollar FOREX swapping scale and as per the forex hypothesis that the conversion standard of a nation is impacted by the forex exchanging meeting and the quantity of exchanges, products and imports completed among nations and the affecting factors are the trade paces of China, Japan, Europe, Gold Prices, Crude Oil.

4 Conclusion

The rules in light of the perceptions from the after effects of the trial and error of this review, the accompanying ends are deduced that ANFIS can be utilized to streamline and break down the rupiah-dollar swapping scale either somewhat or all the while and the affecting variable is the unfamiliar conversion standard of China, Japan, Europe, Gold and Crude Oil as proven by the low MSE esteem. The autonomous variable can likewise be utilized to foresee the development of the rupiah-dollar forex esteem in light of the fact that the MPE esteem is generally little so it can anticipate long haul forex information and contrasts in information types can be overwhelmed by utilizing ANFIS.

References

- [1] K. Abhishek, B. N. Panda, S. Datta, and S. S. Mahapatra, "Comparing Predictability of Genetic Programming and ANFIS on Drilling Performance Modeling for GFRP Composites," *Procedia Mater. Sci.*, vol. 6, no. Iempc, pp. 544–550, 2014, doi: 10.1016/j.mspro.2014.07.069.
- [2] I. Rus et al., "Real Option as a Potential Link between Financial and Strategic Decision-making," *Procedia Econ. Financ.*, vol. 32, no. 15, pp. 232–238, 2015, doi: 10.1016/j.procs.2018.10.523.
- [3] G. S. Atsalakis, C. Ioana, and C. H. Skiadas, "Forecasting Unemployment Rate Using a Neural Network with Fuzzy Inference System," *Icap*, no. June 2014, pp. 1–7, 2007, [Online]. Available: https://www.researchgate.net/publication/4720767_Forecasting_Unemployment_Rate_Using_a_Neural_Network_with_Fuzzy_Inference_System.
- [4] S. A. Monfared and D. Enke, "Volatility forecasting using a hybrid GJR-GARCH neural network model," *Procedia Comput. Sci.*, vol. 36, no. C, pp. 246–253, 2014, doi: 10.1016/j.procs.2014.09.087.
- [5] D. Pradeepkumar and V. Ravi, "Soft computing hybrids for FOREX rate prediction: A comprehensive review," *Comput. Oper. Res.*, vol. 99, pp. 262–284, 2018, doi: 10.1016/j.cor.2018.05.020.
- [6] N. D. Lima and M. E. Student, "FOREX rate prediction using ANN and ANFIS," no. November, 2016.
- [7] R. Dash and P. K. Dash, "Efficient stock price prediction using a Self Evolving Recurrent Neuro-Fuzzy Inference System optimized through a Modified technique," *Expert Syst. Appl.*, vol. 52, pp. 75–90, 2016, doi: 10.1016/j.eswa.2016.01.016.
- [8] S. A. Jalaee, M. Lashkary, and A. GhasemiNejad, "The Phillips curve in Iran: econometric versus artificial neural networks," *Heliyon*, vol. 5, no. 8, p. e02344, 2019, doi: 10.1016/j.heliyon.2019.e02344.
- [9] D. Pradeepkumar and V. Ravi, "Forecasting financial time series volatility using Particle Swarm Optimization trained Quantile Regression Neural Network," *Appl. Soft Comput. J.*, vol. 58, pp. 35–52, 2017, doi: 10.1016/j.asoc.2017.04.014.