

# Multi-Mode, Multi-Band Spectrum Sensor for Cognitive Radios Embedded to a Mobile Phone

Sami Kallioinen\*\*, Mikko Vääräkangas\*, Ping Hui,  
Jani Ollikainen, Ilari Teikari, Aarno Pärssinen\*\*  
Nokia Research Center, Otaniemi, Espoo, Finland  
\*Nokia Research Center, Helsinki, Finland  
\*\*Currently with Renesas Mobile, Helsinki, Finland

Vesa Turunen, Marko Kosunen, Jussi Ryyänen  
Aalto University School of Electrical Engineering  
Department of Micro- and Nanosciences  
SMARAD CoE  
Espoo, Finland

**Abstract**— Localized spectrum sensing is an alternate for database centric approaches to solve secondary use of spectrum in cognitive radios. This can be carried out by using collaborative spectrum sensing where larger amount of small devices is utilized for local spectrum sensing. This paper describes a mobile device scale implementation of multi-mode, multi-band spectrum sensor for cognitive radio. Cyclostationary feature detector algorithm is utilized to detect digital television (DVB-T/H) on UHF band and IEEE802.11a/g on 2.4/5 GHz (ISM/WLAN) bands. A miniaturized spectrum sensing device encounters physical challenges; like limited size and battery capacity, but provides opportunities to establish a dense network and fast response to dynamic changes in signal conditions.

**Keywords** – cognitive radio; spectrum sensing; mobile phone; white space devices; digital television; DVB; UHF; WLAN; cyclostationary; feature detector; intermodulation; radio frequency; broadband

## I. INTRODUCTION

Spectrum sensing is a broadly studied area in cognitive radios and many different algorithms have been developed to find energy [1] or specific protocols, especially TV transmissions and wireless microphones [2], in order to improve spectrum utilization. However, issues related to portability and small mobile phone sized devices are not addressed thoroughly in previous spectrum sensing literature [3]-[7]. Spectrum sensing capability especially in portable, battery limited devices is one of the reasons why database centric approaches are currently considered as core solutions for secondary use of spectrum [8],[9]. Attractiveness of more localized spectrum detection has not vanished [10] and various aspects need to be addressed in the field trials using realistic devices to complement trials using rack-sized equipment [3]. The requirements proposed and later revised by Federal Communications Commission (FCC) in the US have been the first concrete step towards opening licensed frequency band for secondary use [11]. Sensitivity requirement in the FCC ruling is -114 dBm at 6 MHz channel. Required sensitivity level is achievable using known spectrum sensing algorithms as shown later. However it has been questioned that is current sensitivity requirement enough to protect primary users especially in the UHF band [12]. On the other hand, opportunities to determine spectrum collaboratively using larger amount of small devices have not been included in the current rulings.

Another problem and key point in flexible spectrum use is to really find unused spectrum. This relates at least to exact positions of communicating devices and linearity requirements of spectrum sensors. We show by field measurements the importance of the problem when there are strong primary signals in the vicinity. By making sensitivity requirement stricter we decrease possibility of interference caused by white space devices (WSD) to primary signals but this increases unintentional false alarms caused by intermodulation results.

Miniaturization of spectrum sensing devices is not straightforward for small, battery-operated devices. Because signal detection needs to have sufficient margin to protect primaries in the band of interest sensors need to observe signals from significantly lower levels than the actual communication typically requires. Although many algorithms can perform the task at very low SNR values noise of the receiver and especially losses in the antenna and front-end filter pose major challenges for practical implementations. As antenna form factors are larger at lower frequencies and relative bandwidth is typically proportional to receiver front-end losses sensing at UHF band will be performance limited mostly due to antenna losses and intermodulation performance of the receiver ASIC. These aspects will be discussed further in the paper with practical examples from field tests. In addition to UHF band the demonstrated device is also capable of detecting signals at 2.4 GHz ISM and 5 GHz WLAN bands.

Although not discussed in detail power consumption will also be an issue if multitude of channels needs to be monitored frequently. The mechanism does not differ significantly from the principles of cellular paging although individual detection times may be relatively long and in many cases the detection over a larger bandwidth needs to be done sequentially.

## II. SPECTRUM SENSOR EMBEDDED TO A MOBILE DEVICE

In order to conduct field tests using a device with realistic form factor a spectrum sensor was embedded into a Nokia N900 mobile computer with all functionalities. The choice caused some extra challenges since the N900 has not been designed for a mobile TV receiver. Spectrum sensor hardware has been designed on a separate printed circuit board (PCB) and it has been equipped with hardware which enables to receive desired frequency bands and realize all spectrum sensor functionality (Fig. 1). Fig. 2 shows the two complete signal paths that have

---

This research is supported by Tekes (the Finnish Funding Agency for Technology and Innovation).



Fig. 1. The spectrum sensor detector board inside N900 mobile phone.

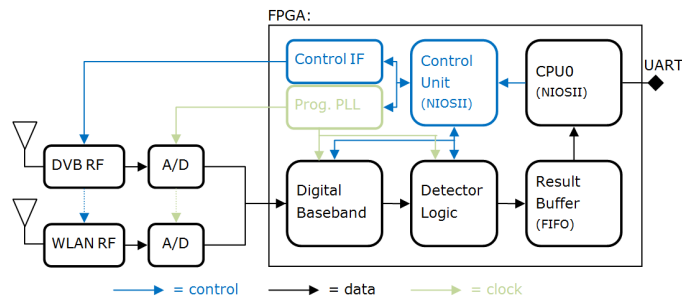

Fig. 2. Blocks on the detector board.

been implemented on the PCB from an antenna element to a FPGA. Two separate RF frontend chips were required: one for UHF frequencies and one for IEEE802.11a/b/g (2.4/5.8 GHz). The used RF receivers are commercial RFIC and they are controlled by the FPGA. The analog baseband data is digitized for the FPGA using two dual 10 bit AD converters operating at maximum rate of 80 MHz, depending on the system under detection. Feature detector algorithms for spectrum sensing have been implemented on the FPGA. Communication between sensor board and the mobile device is done using a universal asynchronous receiver/transmitter (UART). The data rate between the sensor board and mobile device is 1 Mbit/s.

The spectrum sensor board is located inside the display slider case of the device. A custom plastic riser (Fig. 3) was required between the display and the bottom of the case to allow sufficient space for the board. Sensor board is located just behind of the display and on top of the slider mechanic. The slider mechanic is made of metal, as is the background of the display element. To ensure sufficient antenna efficiency both antennas had to be placed to the fin of the plastic riser that is outside the metal frame. It should however be noted that this is only due to the fact that the device has not been designed for spectrum sensor use.

Antenna design, especially at UHF band, is the utmost challenge in a spectrum sensor design. Best efficiency can be achieved with external antennas but for consumer devices embedded antennas have become de facto solutions. Relative bandwidths of the both antennas,

UHF and WLAN, are reasonably high. Size and the location of the antennas inside the mobile device limit their efficiency and matching as well as the surrounding mechanics. Sizes of the antennas has been tried to keep as small as possible without losing performance too much. Antenna miniaturization in a mobile device scale is more problematic for an UHF antenna due to its longer electrical (and physical) length compared to a WLAN antenna.



Fig. 3. Spectrum sensor prototype implementation on N900 mobile phone.

### III. SYSTEM REQUIREMENTS RELATED TO SPECTRUM SENSING

Two very different kind of target systems were addressed: DVB-T as an example of rather static TV primary system and 802.11a/g as an example of system having very dynamic traffic characteristics. Goal was to implement sensing strategy to measure both temporal and spectral characteristics of target systems. Another aspect was to measure spatial channel utilization in the field. We ended up in this phase to traditional channel numbering instead of generalized notation for cognitive radios in order to simplify control.

TV primary sensing requirement by FCC is -114 dBm sensitivity level averaged over a 6 MHz channel. This corresponds to -112.8 dBm averaged over a 8 MHz DVB-T channel in order to keep equal requirements for the detector. In order to measure UHF channel utilization, selected strategy is to make single detection per channel at each studied location. This requires quite low false alarm rate e.g. 1% and high probability of detection e.g. 99%. Excluding antenna losses, the sensor prototype presented in this work could reach these requirements with a sensing time of approximately 115 ms. However, for the longest detection time, i.e. 460ms, the headroom for antenna losses is only about 5dB.

WLAN average temporal channel utilization analysis needs several samples. Detected cyclostationary properties of the 802.11a/g OFDM signal exist in any part of the transmitted packet. Therefore no synchronization is needed to capture average temporal channel utilization if duration of the detection (0.1-0.8 ms in this case) is small compared to average packet length of the 801.11a/g. According to CRAWDAD measurement data, most of the payload data in WLAN networks is generated by TCP protocol. If we calculate upper limit of 802.11a/g packet transmission times, that are longer than the detection time, assuming that all traffic is sent using a maximum 54 mbps data rate, share of packets that are shorter than 100 us is 7.7% and shorter than 200 us 8,8% and most of the packets

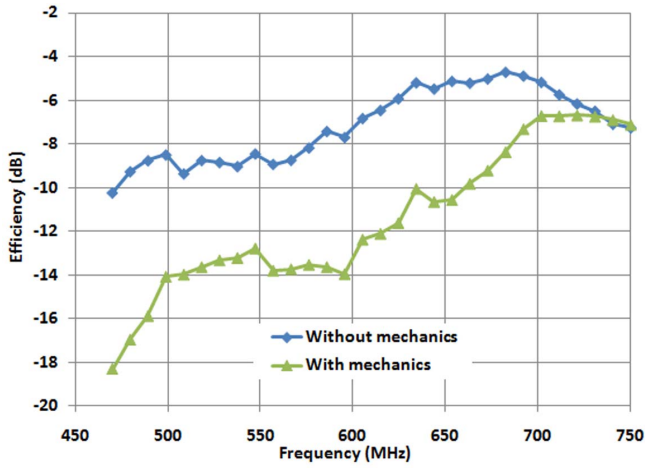

Fig. 4. Efficiency of the UHF antennas.

have length from 240  $\mu$ s up to 2 ms. Number of individual packets in the analyzed data was 500 000 [13],[14]. Sensing strategy is to make 1000 consecutive measurements and calculate average number of positive samples to determine utilization of the channel. Because WLAN can be considered as another secondary system in cognitive communications utilization will guide the decision to operate in channels that have the lowest temporary load and thus less inter-system interference.

#### IV. PLATFORM PERFORMANCE

In order to understand practical limitations of the platform and analyze field test properly the prototype and its core entities were characterized both separately and as a complete system.

##### A. Antenna

Two antennas were implemented inside the presented mobile spectrum sensing device. For UHF frequencies a commercial antenna which based on planar technology has been used. Dimensions of the antenna are 45 mm x 5 mm and it has been designed to work at frequency range from 470 to 750 MHz (DVB-H EU). Antenna for 802.11a/b/g has been realized as a wideband structure which covers frequency range from 2 to 6 GHz. It has been implemented directly to the same PCB than the spectrum sensor. It requires slightly more area than the UHF antenna (32 mm x 8 mm).

Both antennas were measured with and without the device mechanics to understand differences compared to conventional stand-alone antenna testing, and to evaluate actual performance in the field. Measurement results for the UHF antenna are presented in Fig. 4 and wideband antenna in Fig. 5. Deterioration of the efficiency of the UHF antenna due to mechanics is significant (6-8 dB) at low frequencies. The wideband antenna behaves better and its efficiency deterioration due to mechanics is only 1-2 dB over the whole band. The efficiencies of the antennas are -18(-7)/-3/-6(-4) dBs at UHF/2.4/5 GHz bands, respectively, depending on the specific channel. The results clearly indicate the issue of antenna performance at UHF band in small devices.

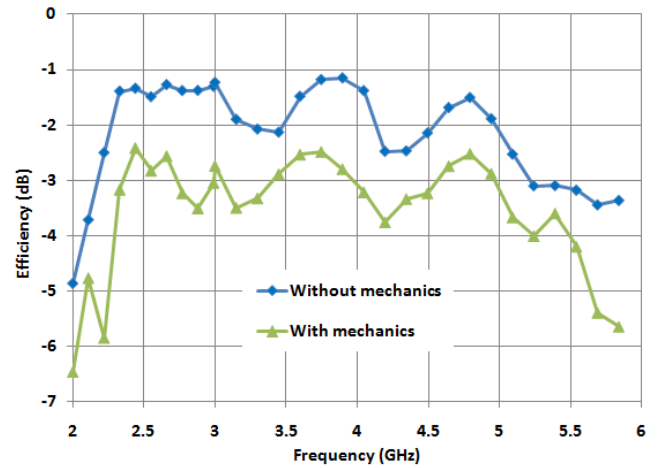

Fig. 5. Efficiency of the wideband 802.11a/b/g antenna.

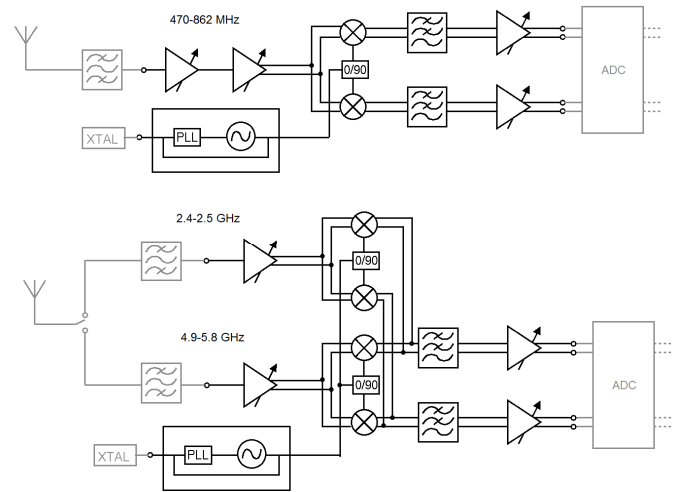

Fig. 6. Block diagram of the UHF (a) and 802.11 a/b/g (b) receiver.

##### B. RF

The used RF receivers are commercial RFIC and they are based on a direct-conversion architecture. Baseband filters are adjustable and they support several bandwidths used in different standards. Block diagrams of the receivers are presented in Fig. 6. Typical noise figure (NF) of all receivers without front-end filter is around 4 dB depending on the band. Typical insertion-losses of front-end filter are 1.8 dB at UHF/2.4 GHz bands and 1.4 dB at 5 GHz band.

##### C. Detector

Detector core on the FPGA is developed from the FFT-based cyclostationary feature detector formerly presented by the authors in [15]. The structure of the detector is shown in Fig. 7. The fixed-size-FFT implementation utilizes decimation after autocorrelation to control the detection time. Test for the presence of cyclostationary at given cyclic frequency ( $\alpha$ ) is performed from the FFT of the decimated autocorrelation signal.

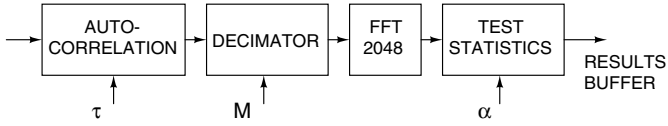

Fig. 7. Structure of the implemented cyclostationary feature detector.

In this implementation, the range of selectable decimation ratios is extended up to  $M=2048$  to support longer detection times. Similarly, the maximum autocorrelation delay ( $\tau_{\max}$ ) is increased to 8192. The modifications were required to enable detection of very long OFDM symbols used in DVB-T signals. The detector implementation utilizes 16k logic elements, 406k memory bits and 84 9-bit multiplier elements. The figures are 10.2%, 13.7% and 14.6% of all available resources on the FPGA, accordingly.

Detector sensitivity was measured for a WLAN [14] signal at 2.4 GHz ISM band and for a DVB-T [16] signal at the UHF band. Parameters related to modulation, signal bandwidth and transmit frequency of both systems are summarized in TABLE I. During the measurements, the antennas were bypassed and the signal generator was connected directly to the RF receiver inputs, therefore the results exclude any antenna effects. The RF receivers operate at maximum gain. Detection times for WLAN and DVB-T were set to 0.8 ms and 460ms, accordingly. False alarm rate is 5%.

TABLE I. SPECIFICATIONS OF THE PRIMARY SIGNALS USED IN DETECTOR PERFORMANCE MEASUREMENTS.

	WLAN	DVB-T
Modulation:	OFDM	OFDM
FFT-size ( $N_{FFT}$ )	64	8192
Length of cyclic prefix ( $N_{CP}$ )	16	1024
No. of non-zero subcarriers	52	6817
Subcarrier modulation	16-QAM	16-QAM
Transmit frequency	2437 MHz	670 MHz
Bandwidth	20 MHz	8 MHz

The measured sensitivities are presented in Fig. 8 for DVB-T and in Fig. 9 for WLAN signal. DVB-T detection reaches 95% probability of detection when the received power is about -117 dBm, while for the WLAN detection received power of -102 dBm is required. Both figures are below the thermal noise floor. Fig. 8 and Fig. 9 also show ideal simulation results for the same signals. The differences between simulated and measured probability of detections almost entirely match and are accounted by the non-zero noise figures of the RF receivers. The primary reason that DVB-T detection outperforms WLAN detection by such a large margin is the longer detection time that can be utilized in DVB-T detection. WLAN detection time is limited on the other hand by implementation, where larger FFT would be required to keep the cyclic frequency under the Nyquist frequency for larger decimation ratios, and on the other hand by duration of WLAN signal bursts which is already on the same scale with the detection time.

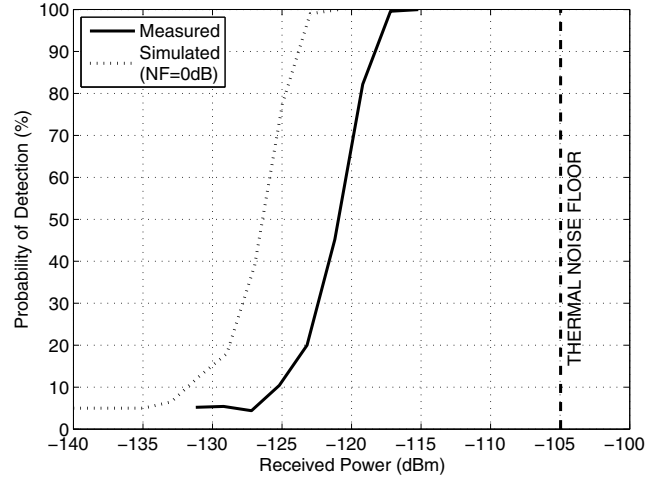

Fig. 8. Measured DVB-T probability of detection compared to simulated performance. Simulation utilizes ideal receiver (NF=0dB).

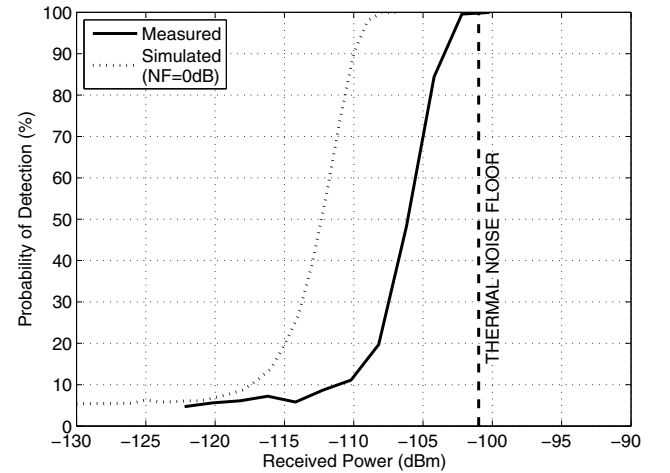

Fig. 9. Measured WLAN probability of detection compared to simulated performance. Simulation utilizes ideal receiver (NF=0dB).

#### D. Platform Performance

Overall performance for the spectrum sensor hardware has been determined in the laboratory measurements. A 5 dB NF for UHF receiver path was measured at 660 MHz and it is only 1 dB more than NF of the pure UHF receiver. For dual-band 802.11a/b/g receiver, 5 dB and 6.5 dB NF at 2.427 and 5.130 GHz were measured, respectively. IIP3 of -10 dBm, -1 dBm and -1 dBm were measured for UHF, 2.4 and 5 GHz bands, respectively.

When combined with antenna results the overall sensitivity of the signal detection for DVB-T signals at UHF band will be from -100 to -108 dBm depending on the channel of interest. This is significantly higher than FCC requirements but shows feasible values for small devices if the integration time of the detection is kept reasonable. IIP3 of the UHF receiver with antenna corresponds 8 - (-3) dBm compared to 0 dB antenna in the field tests. At some channels platform noise caused by processors and other noisy components in the device will further deteriorate the performance. However, those could be mostly avoided with proper design when UHF band requirements will be taken into account initially in the design of the device and its

mechanics. For WLAN OFDM signal detection, the sensitivities using parameters given earlier in this paper will be  $-101$  and  $-98$  dBm (2.4 / 5 GHz) including the antenna.

## V. FIELD TRIALS

Field tests were carried out in capital area in Finland [17]. The measurement set was done mostly outdoors in urban Ruoholahti area in Helsinki. The measurement set consists of spectral samples from 37 different locations, One spectral sample includes detection time, GPS location, band, channel, received signal strength in dBm and DVB-T detection statistics from UHF channels 34 to 60 (578 – 784 MHz). Detection time was set to 460 ms and detection statistics positive detection threshold to produce constant false alarm rate of 1%. Example of spectral sample is shown in Fig. 10. Estimated probabilities of DVB-T detections on different channels are shown in Fig. 10. There is DVB-H repeater in the area, detected on channel 35. Espoo TV transmitter is transmitting on channels 32, 44, 46, and 53.

TV transmissions on measurement range are detected with high probability. Channel 59 is occupied by Tallinn TV transmitter on average 78 km away and it is out of the reach for typical TV reception setups in Helsinki households. Splat! [18] radio propagation calculation tool was used for field strength estimation. It is based on Longley-Rice Irregular Terrain Model and uses Space Shuttle Radar Topography Mission elevation data in propagation calculations. Used transmitter parameters are shown in TABLE II. , receiver was assumed to be 3m above sea surface. Estimated field strength in Ruoholahti area is 20-60 dB $\mu$ V/m. With measured antenna efficiency of  $-7.5$  dB, it corresponds  $-123$  –  $(-83)$  dBm signal input power at the receiver. Taking measured detector sensitivity into account we end up 0.6 to 1 detection probability of Tallinn TV transmitter in Ruoholahti, Helsinki. Tallinn transmission on channel 45, adjacent to much stronger Espoo TV transmitter on channel 44 and 46, is masked and it cannot be detected.

## VI. CONCLUSIONS

We have integrated a spectrum sensor for the detection of primaries and other radio systems at white space/UHF, 2.4 and 5 GHz bands inside a functional smart phone. The device is capable of detecting current TV and WLAN transmissions. Key performance tradeoffs have been shown in the laboratory tests and functionality proven in the field when observing operating TV stations and access points. The key challenge is antenna integration and the strictest FCC ruling requirements cannot be met using a single device and especially single shot decisions.

However when collecting more samples, position information and combining the results from several devices, a local and dynamic data base can be established to find spectral opportunities in tighter raster than in centralized, computational data bases. When combined with analysis measured data can improve reliability to detect primaries, like TV channels, but in addition to define dynamic opportunities amongst secondaries operating in the band. Hence, more field testing is required with smart phone size devices to find practical opportunities of mobile spectrum sensors to support future cognitive radios when avoiding primary signals and operating smoothly with other secondary systems.

TABLE II. DVB-T TRANSMITTER PARAMETERS.

DVB-T transmitters	Espoo	Tallinn
Latitude:	60.1778	59.4713
Longitude:	24.6403	24.8875
Mast height:	313 m	272 m
Transmission power:	47 dBm	42 dBm
Occupied channels	32, 35, 44, 46, 53	45, 59, 64

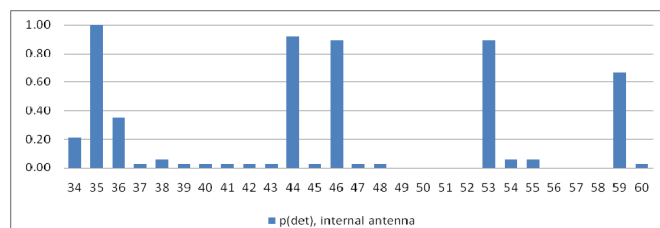

Fig. 10. Measured probability of DVB-T detection,  $n = 37$  per channel, average distance to Espoo transmitter 15 km and 78 km to Tallinn transmitter.

## REFERENCES

- [1] F. F. Digham, et al., "On the Energy Detection of Unknown Signals Over Fading Channels," *IEEE Trans. Commun.*, vol. 55, pp. 21–24, Jan. 2007.
- [2] M. Ghosh, et al., "Spectrum Sensing Prototype for Sensing ATSC and Wireless Microphone Signals," in *Proc. Int. Conf. Cognitive Radio Oriented Wireless Networks and Communications*, 2008, pp.1-7.
- [3] OET, "Evaluation of the Performance of Prototype TV-band White Space Devices Phase II", OET rep. FCC/OET 08-TR-1005, Oct. 2008.
- [4] Demonstration of a Prototype Dynamic Spectrum Access System, Philips Research, in DySPAN demo session, 2008.
- [5] Ser Wah Oh, et al, "White-Space Sensing Device for Detecting Vacant Channels in TV Bands," in *Proc. Int. Conf. Cognitive Radio Oriented Wireless Networks and Communications*, 2008, pp.1-6.
- [6] Yuan Yuan, et al , "KNOWS: Cognitive Radio Networks Over White Spaces," in *Proc. IEEE Int. Symp. New Frontiers in Dynamic Spectrum Access Networks*, 2007, pp. 416-427.
- [7] V. Gaddam, M. Ghosh, "Robust Sensing of DVB-T Signals," in *Proc. IEEE Int. Symp. New Frontiers in Dynamic Spectrum Access Network*, 2010, pp 1-8.
- [8] FCC, "Public Notice", ET Docket No. 04-186, Nov. 2009. [http://hraunfoss.fcc.gov/edocs\\_public/attachmatch/DA-09-2479A1.doc](http://hraunfoss.fcc.gov/edocs_public/attachmatch/DA-09-2479A1.doc)
- [9] FCC News, "FCC Frees Up Vacant TV Airwaves for "Super Wi-Fi" Technologies," , Sep. 2010. [http://www.fcc.gov/Daily\\_Releases/Daily\\_Business/2010/db0923/DOC-301650A1.pdf](http://www.fcc.gov/Daily_Releases/Daily_Business/2010/db0923/DOC-301650A1.pdf)
- [10] FCC News, "FCC Crafts Proposals to Boost Spectrum Research and Spectrum Efficient Wireless Technologies," , Nov. 2010. [http://www.fcc.gov/Daily\\_Releases/Daily\\_Business/2010/db1130/DOC-303096A1.pdf](http://www.fcc.gov/Daily_Releases/Daily_Business/2010/db1130/DOC-303096A1.pdf)
- [11] FCC, "Second Report and Order and Memorandum Opinion and Order," ET Docket No. 08-260, Nov. 2008.
- [12] FCC, "Second Memorandum Opinion And Order", ET Docket No. 10-174, Sep. 2010.
- [13] <http://crawdad.cs.dartmouth.edu/>
- [14] Wireless LAN medium access control (MAC) and physical layer (PHY) specifications, IEEE Standard 802.11<sup>TM</sup>-2007, Jun. 2007.
- [15] V. Turunen, et al, "Implementation of cyclostationary feature detector for cognitive radios," in *Proc. Int. Conf. Cognitive Radio Oriented Wireless Networks and Communications*, 2009, pp. 1-4.
- [16] Digital video broadcasting (DVB); framing structure, channel coding and modulation for digital terrestrial television, ETSI EN 300 744, Jan. 2009
- [17] M. Vääräkangas, et al, "Trade-offs in Primary Detection Using a Mobile Phone as a Sensing Device," accepted to . *Int. Conf. Cognitive Radio Oriented Wireless Networks and Communications*, 2011, pp.1-4.
- [18] <http://www.qsl.net/kd2bd/splat.html>