

Automatic Tooth Color Tester Device

Ipin Prasajo ^{1*}, Nishith Shahu ², Lastuti Abubakar ², Irfan Ahmad ³, Nia Maharani Raharja ⁴

¹Department of Electrical Engineering, ITS PKU Muhammadiyah Surakarta, Solo, Surakarta

²polytechnic college to Gujarat Technological University, India

³Khurasan university, Nangarhat, Afghanistan

⁴Department of Electrical Engineering, Universitas Islam Negeri Sunan Kalijaga, Yogyakarta, Indonesia

* rmprasojo@gmail.com

Abstract. Teeth have a very meaningful function for humans which is to help chew, cut food. Therefore the teeth must be treated properly. Although treatment has been done but there are still changes in tooth color. This device can reduce human error from medical officers who conduct examinations. Besides these things, this device is also very useful for determining the colors of teeth in accordance with existing parameters. In this module the average percentage of errors in the color of white teeth is + 2.32%, the color of yellow teeth is + 2.53%, while the color of brown teeth is + 2.34%, and the Ua value of the measurement results is 0.01 while the U95 value is 0.04. From the results of voltage measurements on the colors of yellow and brown teeth there is the same voltage, this is due to differences in the thin color of the teeth, the measurement position of the reading and selection of sensors and the light source used.

Keywords: Tooth color, LDR sensor, LED, microcontroller.

1 Introduction

In line with the increasingly rapid advances in technology that encourage people to think about doing activities and activities easily and lightly, so the old ways and need a long time are increasingly abandoned. In the field of medicine, the development of this technology will facilitate the operation of medical device, one of which is a teeth instrument.

As it is known that teeth are an important part in the process of digestion. With genetic influences and external influences such as diet and differences in tooth sensitivity, can affect tooth color. According to the author's observations of the examination of tooth discoloration is currently still done manually by means of matching with the teeth color measurement card.

2 Method

The research design used in the preparation of this Final Project is a research design that is Pre-Experimental. This type of research used in the preparation of this Final Project is a type of research "After Only Design" which is only to see the results of teeth color measurement automatically without seeing before. But there is already a control group that is measuring the color of teeth manually. The weakness of this study is that it does not know the initial situation, so the results obtained are difficult to conclude.

In designing this device there are two variables used including:

- Independent Variables [1]: Independent variables are often called influence variables treatment variable, in this case acting the independent variable is the tooth color level.
- Bound Variables: Bound variables are often called effect variables, variable is affected, not free, in this case which acts as a dependent variable is Resistance to LDR [2]–[8].

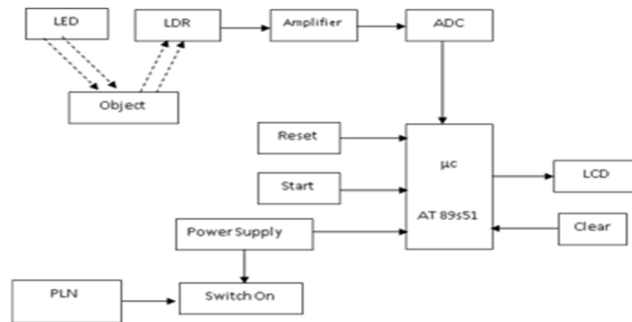

Figure 1. System block diagram

The grid provides the voltage to the power supply, the AC voltage will be converted into a DC voltage. The voltage will supply all circuits when the On switch is pressed while to start the check then press the start button. LEDs provide light to the object so that the light is reflected to the LDR [9]–[14], where the output from the LDR will be input to the amplifier to be strengthened so that the ADC can read it. The output from the amplifier will go into the ADC circuit to be converted into digital data where the output will be processed by the IC microcontroller [15]–[20] which then the processed results will be displayed on the LCD. To repeat the inspection then press the clear button.

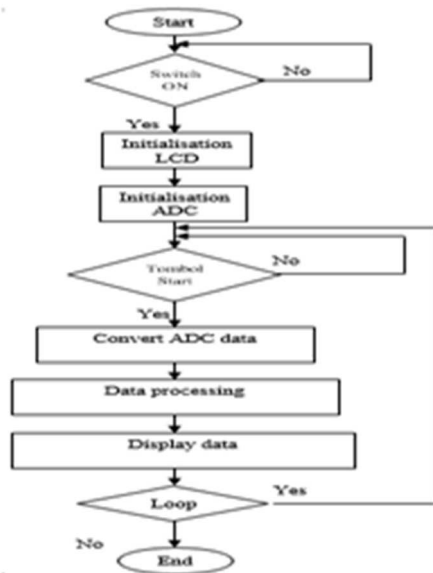

Figure 2. System work flow

The workflow system [21]–[32] shown in the figure consists of Start the device process. Switch On. To begin the introduction of LCD and ADC. LCD initialization. Introduction of LCD. ADC initialization. Introduction of ADC. Start. To start reading. ADC changed the analog trade entered to be made a digital trade so that it could be sent to Micro. Retrieve ADC data from the conversion results. LCD Displays the final results of the microcontroller. This LCD serves to display the final results of the Micro in the form of the text of the teeth. If yes, then return to the initial process, but if not, then go down (END).



Figure 3. Device visualisation

Tooth discoloration is an average tooth color disorder that can be seen clinically. Color changes can be divided into the following categories:

Formative color changes. This type of color change is hereditary or congenital. The causes for this formative color change are:

- a. Erythroblastosis Fetalis is anemic congenital hemolysis, a blood rupture which results in structural disruption and discoloration of teeth - teeth. This happens because of a mismatch of proteins in the fetus and maternal blood, which is called rhesusfactor (Rh). The result of rhesusfactor is an anemic severe hemolysis, which appears as jaundice (Icterus Gravis Neonatorum). Tooth color changes that will occur vary greatly: green, blue, gray, yellow and brown. The cause of this change is the presence of bilirubin in the teeth bones and these changes will disappear little by little.
- b. Fluorosis Endemila is an email that has fluorosis that shows opacity. Brown discoloration occurs due to infiltration of color ingredients from food.

Tetracycline discoloration

Tooth discoloration that occurs due to antibiotics given during infancy, this antibiotic is often known as Tetracycline. The original tetracycline used causes a yellow discoloration under fluorescent UV light. Oxidation affected by sunlight darkens yellow to brown.

Sensors schematic

- a. LED. In making this device, the authors use LEDs as a light source on teeth which will be captured by the LDR with different intensities according to the media (teeth). These LEDs are usually referred to as light diodes, when given a forward bias or forward currents generate light at the P-N meeting. At the time of recombination the electrons that release their energy will produce light or heat. This diode has two legs, namely anode and cathode.

LED (Light Emitting Diode) is a diode that can emit light when the legs are stressed according to the required voltage. There are two LED voltage sources that can be given

AC voltage for AC LEDs and DC voltage for DC LEDs (In DC LEDs the voltage should not be reversed).

- b. LDR. In making this device, the author uses the LDR as a series of light sensor transducers that is receiving light reflection from the media (teeth).

LDR is a resistor whose resistance changes because of changes in the intensity of the light absorbed. LDR is also a resistor that has a negative temperature coefficient, where the resistance is influenced by light intensity. LDR is formed from Cadmium Sulfide (CDS) or ceramic powder. In general, CDS is also called Photo Conductive equipment, as long as there are variations in light intensity.

Buffer schematic

LM 741 IC as an operational amplifier. The LM 741 Series is an operational amplifier for general use that looks better than the industry standard. This amplifier has properties that are always right and can protect the inserted and removed material. Op-Amp 741 which is produced by national semiconductor has 1 Op-Amp that is operated with dual supply, namely + 12 V and -12 V.

ADC 0804 schematic

ADC is an extension of Analog to Digital Converter which means converter from analog to digital. The function of the ADC is to convert analog data into digital data which will later be entered into a digital component, the AT89S51 microcontroller.

There are 2 inputs from ADC, namely positive (+) and negative (-) inputs. The ADC 0804 consists of an 8 bit Analog to Digital Converter microprocessor.

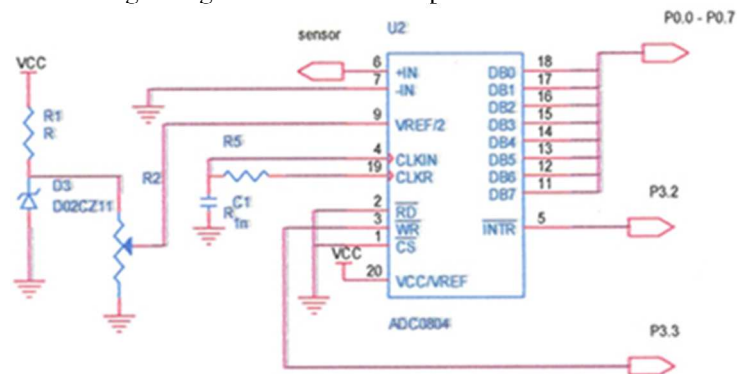

Figure 4. ADC 0804 schematic diagram

$V (+)$ and $V (-)$ are input analog differential voltage so that the voltage data to be processed by the ADC is the difference between $V_i (+)$ and $V_i (-)$. V_{ref} is the ADC reference voltage used to adjust the input voltage at $V_i +$ and $V_i -$. This reference voltage is half the maximum input voltage. It is intended that at the time of maximum input of digital data will also be maximized. The clock frequency of the ADC can be regulated by external R and C components on the Rclk and Cclk pins.

Chip select function is to activate the ADC which is activated by logic low. Read is input that is used to read digital data from active convection results in low conditions. Write function to start the ADC conversion is activated in low logic conditions. The instruction is to detect whether the conversion has been completed or not, if it has, then the instruction pin will issue a logic low. Digital output data as much as 8 bytes (DB0 - DB7) binary 0000 0000

through 1111 1111, so the possibility of decimal numbers that will appear is 0 to 255 can be taken a

pins D0 through D7. DB0 - DB7 has latching properties.

Microcontroller minimum system schematic

AT89S51 Microcontroller IC is a component of Atmel's production oriented control with CMOS logic level. This component belongs to the MCS '51 family. The integration circuit has a single chip microcomputer equipment. The equipment in question is the CPU (Central Processing Unit) which consists of components that are interconnected with other components. Among them are the Register, ALU (Arithmetic Logic Unit) and the Control Unit.

LCD schematic

LCD is a dot matrix display that is used to display writing in the form of numbers or letters as desired (according to the program used to control it). In this final project the author uses a dot matrix LCD with 2 x 16 characters, so the legs are 16 pins

3 Results And Discussion

3.1 System Test Result

After making the module it is necessary to conduct testing and measurement. For this reason, the authors make data collection through a process of measurement and testing. The purpose of the measurement and testing is to determine the accuracy of the module making by the author or to ascertain whether each part (component) of the series of modules in question has worked in accordance with its function as planned.

Table 1. The Measurement results of the tooth color output voltage from sensor

No	Teeth color		
	White	Yellow	Brown
1	1.22 Volt	1.11 Volt	1.05 Volt
2	1.20 Volt	1.09 Volt	1.08 Volt
3	1.19 Volt	1.10 Volt	1.00 Volt
4	1.18 Volt	1.06 Volt	1.02 Volt
5	1.14 Volt	1.07 Volt	1.05 Volt

In this module the voltage measurement results on the color of white teeth obtained an error percentage of 2.34%, the uncertainty value in the measurement of 0.01 and this device is feasible to use because $-U_{95} < \text{measuring value} > +U_{95}$ namely: $1.005 < 1.07 > 1,07$.

From the results of voltage measurements on the yellow and brown teeth of the same voltage range (Brown teeth: 1.08 Volts), this can be caused by differences in the thin color of the teeth and the measurement position of the readings, so the reading results can change.

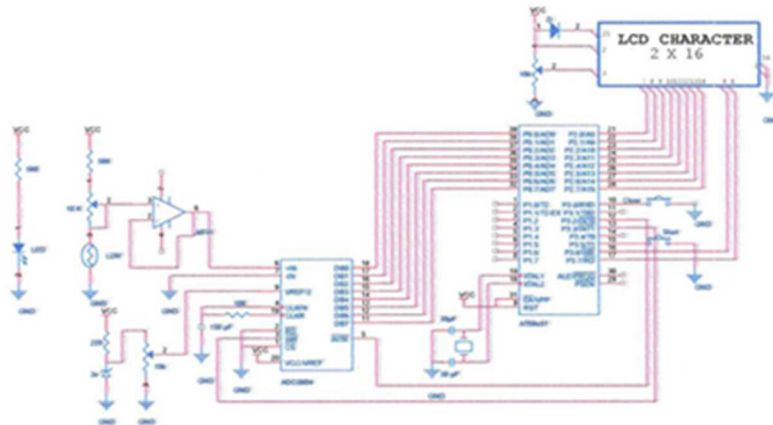

Figure 5. Overall system schematic

This circuit is powered by DC voltages +5, +12 and -12 Volts, where the voltage is obtained from the regulator circuit. +5 Volt DC voltage is used to supply the target board circuit (AT89s51 microcontroller), ADC 0804, LCD and sensors (LED and LDR). Voltage +12 and -12 Volt DC are used to supply the amplifier circuit (Buffer).

The sample used here is teeth. From the sample will get light from the LED which is then reflected by the teeth to the LDR, the results of the reflection will be forwarded to the amplifier circuit (buffer). Output from the buffer circuit in the form of analog voltage will be converted into digital data through IC ADC 0804.

After that, ADC 0804 data waits for commands from the microcontroller in the form of pressing the start button. If the start button is pressed then the ADC data will be entered or received by the microcontroller through port 0. The microcontroller then processes the data received from ADC 0804 and translates it as a type of tooth color, the results of the translation will be displayed to the LCD. To repeat the reading then press the clear button then press the start button.

4 Conclusions

After conducting the experiment it turns out that the Teeth Color Test Device can be made using LED and LDR sensors, the LED here functions as a light source and the LDR functions as a light sensor transducer, which receives light reflection from the media (teeth), from the sensor the voltage is 1.22 Volt ; 12Volt and 1.07Volt which voltage will be processed by micro, so the results will be displayed on the LCD, namely white, yellow and brown teeth.

- a. Color reading of teeth using LEDs and LDR that is by illuminating the LEDs on the teeth which then results of the gear is received by the LDR, with the amount of light used is 1345Lux and with a reading distance of 2.5 cm.
- b. Teeth color test equipment is usually used to determine teeth warrants, which in everyday life are commonly used in the installation of denture
- c. In this module the average percentage of errors in the color of white teeth is + 2.32%, the color of yellow teeth is + 2.53%, while the color of brown teeth is + 2.34%, and the U_a value of the measurement results is 0.01 while the U_{95} value is 0.04.

- d. From the results of voltage measurements on the colors of yellow and brown teeth there is the same voltage, this is due to differences in the thin color of the teeth, the measurement position of the reading and selection of sensors and the light source used.
- e. The use of a microcontroller circuit in this device is very supportive for controlling the color of the teeth automatically, reading the size results and summing up the size results including white, yellow or brown teeth.

References

- [1] J.-J. Huang, H.-Y. Syu, Z.-L. Cai, and A. R. See, "Development of a long term dynamic blood pressure monitoring system using cuff-less method and pulse transit time," *Measurement*, vol. 124, no. April, pp. 309–317, Aug. 2018.
- [2] N. Hassan, S. I. Abdullah, A. S. Noor, and M. Alam, "An automatic monitoring and control system inside greenhouse," in *2015 3rd International Conference on Green Energy and Technology (ICGET)*, 2015, pp. 1–5.
- [3] I. J. Gabe, A. Buhler, D. Chesini, and F. Frosi, "Design and implementation of a low-cost dual-axes autonomous solar tracker," in *2017 IEEE 8th International Symposium on Power Electronics for Distributed Generation Systems (PEDG)*, 2017, pp. 1–6.
- [4] A. Saxena, C. S. Satsangi, and A. Saxena, "Collective collaboration for optimal path formation and goal hunting through swarm robot," in *2014 5th International Conference - Confluence The Next Generation Information Technology Summit (Confluence)*, 2014, pp. 309–312.
- [5] H. Singh, V. Pallagani, V. Khandelwal, and U. Venkanna, "IoT based smart home automation system using sensor node," in *2018 4th International Conference on Recent Advances in Information Technology (RAIT)*, 2018, pp. 1–5.
- [6] R. Kumar and A. Kumar, "Design and hardware development of power window control mechanism using microcontroller," in *2013 INTERNATIONAL CONFERENCE ON SIGNAL PROCESSING AND COMMUNICATION (ICSC)*, 4692, pp. 361–365.
- [7] T. Ahmed, Sheik Md. Kazi Nazrul Islam, I. Chowdhury, and S. Binzaid, "Sustainable powered microcontroller-based intelligent security system for local and remote area applications," in *2012 International Conference on Informatics, Electronics & Vision (ICIEV)*, 2012, pp. 276–280.
- [8] A. Murthy, S. S. Rao, M. A. Herbert, and Navin Karanth P, "Experimental study on linear displacement measurement sensor using RGB color variation technique with PID controller," in *2017 International Conference on Computer, Communications and Electronics (Comptelix)*, 5092, pp. 241–247.
- [9] V. Abilash and J. P. C. Kumar, "Arduinio controlled landmine detection robot," in *2017 Third International Conference on Science Technology Engineering & Management (ICONSTEM)*, 2017, vol. 2018-Janua, pp. 1077–1082.
- [10] I. Lita, D. A. Visan, I. B. Cioc, A. G. Mazare, and R. M. Teodorescu, "Indoor environmental parameters monitoring for building automation systems," in *2016 8th International Conference on Electronics, Computers and Artificial Intelligence (ECAI)*, 2016, pp. 1–4.
- [11] I. Amri, E. Dian Atmajati, R. A. Salam, E. Yuliza, M. M. Munir, and Khairurrijal, "Potentiometer a simple light dependent resistor-based digital," in *2016 International Seminar on Sensors, Instrumentation, Measurement and Metrology (ISSIMM)*, 2016, pp. 24–27.
- [12] P. B. Sowmiya, B. K. Nagaswetha, and D. Priyadarshini, "Design of Automatic Nutrition Supply System Using IoT Technique in Modern Cities," in *2017 International Conference on Technical Advancements in Computers and Communications (ICTACC)*, 2017, vol. 2017-Octob, pp. 109–111.

- [13] M. Belkasm, K. Bouziane, M. Akherraz, T. Sadiki, M. Faqir, and M. Elouahabi, "Improved dual-axis tracker using a fuzzy-logic based controller," in 2015 3rd International Renewable and Sustainable Energy Conference (IRSEC), 2015, pp. 1–5.
- [14] H. Rashid, I. U. Ahmed, S. M. T. Reza, and M. A. Islam, "Solar powered smart ultrasonic insects repellent with DTMF and manual control for agriculture," in 2017 IEEE International Conference on Imaging, Vision & Pattern Recognition (icIVPR), 2017, pp. 1–5.
- [15] N. H. Wijaya, Z. Oktavihandani, K. Kunal, E. T. Helmy, and P. T. Nguyen, "Tympani Thermometer Design Using Passive Infrared Sensor," *J. Robot. Control*, vol. 1, no. 1, pp. 27–30, 2020.
- [16] K. Kunal, A. Z. Arfianto, J. E. Poetro, F. Waseel, and R. A. Atmoko, "Accelerometer Implementation as Feedback on 5 Degree of Freedom Arm Robot," *J. Robot. Control*, vol. 1, no. 1, pp. 31–34, 2020.
- [17] P. Megantoro, A. Widjanarko, R. Rahim, K. Kunal, and A. Z. Arfianto, "The Design of Digital Liquid Density Meter Based on Arduino," *J. Robot. Control*, vol. 1, no. 1, pp. 1–6, 2020.
- [18] N. H. Wijaya, A. G. Alvian, A. Z. Arfianto, J. E. Poetro, and F. Waseel, "Data Storage Based Heart and Body Temperature Measurement Device," *J. Robot. Control*, vol. 1, no. 1, pp. 11–14, 2020.
- [19] T. P. Tunggal, A. W. Apriandi, J. E. Poetro, E. T. Helmy, and F. Waseel, "Prototype of Hand Dryer with Ultraviolet Light Using ATMega8," *J. Robot. Control*, vol. 1, no. 1, pp. 7–10, 2020.
- [20] A. Latif, K. Shankar, P. T. Nguyen, U. Islam, and S. Agung, "Legged Fire Fighter Robot Movement Using PID 1," *J. Robot. Control*, vol. 1, no. 1, pp. 15–19, 2020.
- [21] A. N. N. Chamim, M. Heru Gustaman, N. M. Raharja, and I. Iswanto, "Uninterruptable Power Supply based on Switching Regulator and Modified Sine Wave," *Int. J. Electr. Comput. Eng.*, vol. 7, no. 3, p. 1161, Jun. 2017.
- [22] Iswanto, J. Syafridi, A. Nur, N. Chamim, R. O. Wiyagi, and R. Syahputra, "LED and Servo Motor Control Via Bluetooth Based on Android Applications," *Int. J. Recent Technol. Eng.*, vol. 8, no. 2, pp. 6227–6231, Jul. 2019.
- [23] A. N. N. Chamim, M. E. Fawzi, I. Iswanto, R. O. Wiyagi, and R. Syahputra, "Control of Wheeled Robots with Bluetooth-Based Smartphones," *Int. J. Recent Technol. Eng.*, vol. 8, no. 2, pp. 6244–6247, Jul. 2019.
- [24] D. Hardiyanto, I. Iswanto, D. A. Sartika, and M. Rojali, "Pedestrian Crossing Safety System at Traffic Lights based on Decision Tree Algorithm," *Int. J. Adv. Comput. Sci. Appl.*, vol. 10, no. 8, pp. 375–379, 2019.
- [25] I. Iswanto, "Ar-Drone Navigation Based on Laser Sensor and Potential Field Algorithm," *Int. Rev. Aerosp. Eng.*, vol. 11, no. 6, p. 260, Sep. 2018.
- [26] A. N. N. Chamim, D. Ahmadi, and Iswanto, "Atmega16 implementation as indicators of maximum speed," *Int. J. Appl. Eng. Res.*, vol. 11, no. 15, pp. 8432–8435, 2016.
- [27] K. Purwanto, I. -, T. Khristanto, and M. Yusvin, "Microcontroller-based RFID, GSM and GPS for Motorcycle Security System," *Int. J. Adv. Comput. Sci. Appl.*, vol. 10, no. 3, pp. 447–451, 2019.
- [28] H. H. Triharminto, O. Wahyunggoro, T. B. Adji, A. Cahyadi, I. Ardiyanto, and Iswanto, "Local information using stereo camera in artificial potential field based path planning," *IAENG Int. J. Comput. Sci.*, vol. 44, no. 3, pp. 316–326, 2017.
- [29] P. Ananto, M. Saifussalam, R. Inovan, Iswanto, and A. I. Cahyadi, "Coverage control on multi-agent system," in 2016 6th International Annual Engineering Seminar (InAES), 2016, pp. 37–41.
- [30] A. Maarif, S. Iskandar, and I. Iswanto, "New Design of Line Maze Solving Robot with Speed Controller and Short Path Finder Algorithm," *Int. Rev. Autom. Control*, vol. 12, no. 3, p. 154, May 2019.

- [31] T. Padang Tunggal, A. Supriyanto, N. M. Zaidatur Rochman, I. Faishal, I. Pambudi, and I. Iswanto, "Pursuit Algorithm for Robot Trash Can Based on Fuzzy-Cell Decomposition," *Int. J. Electr. Comput. Eng.*, vol. 6, no. 6, p. 2863, Dec. 2016.
- [32] R. Mubarak, D. Verdy Firmansyah, D. Haryanto, N. Pratama Apriyanto, U. Mahmudah, and I. Iswanto, "Motorcycle-Security using Position Searching Algorithm Based on Hybrid Fuzzy-Dijkstra," *Indones. J. Electr. Eng. Comput. Sci.*, vol. 3, no. 2, p. 468, Aug. 2016.