

# Enhanced vertical handover based on 802.21 framework for real-time video streaming

Michail Tsagkaropoulos  
Dept. Electrical&Comp.  
Engineering  
University of Patras  
26500 Rio, Greece  
Tel: +30 2610 996465  
mtsagar@ece.upatras.gr

Ilias Politis<sup>\*</sup>  
Dept. Electrical&Comp.  
Engineering  
University of Patras  
26500 Rio, Greece  
Tel: +30 2610 996465  
ipolitis@ece.upatras.gr

Tasos Dagiuklas  
Dept. Telecommunication  
Systems & Networks  
TEI of Messolonghi  
Greece  
Tel: +30 26310 58486  
ntan@teimes.gr

Stavros Kotsopoulos  
Dept. Electrical&Comp.  
Engineering  
University of Patras  
26500 Rio, Greece  
Tel: +30 2610 996466  
kotsop@ece.upatras.gr

## ABSTRACT

This paper presents a novel middleware architecture in order to support multimedia services across inter-technology nodes in a seamless manner and with minimum perceived QoS degradation. The proposed architecture is based on the Media Independent Handover (MIH) framework. The novelty of the proposed architecture is based on a number of enhancements on top of the original MIH scheme. Firstly, the handover decision function is based on triggering/collecting statistics from physical, network and application layer, so that an ongoing multimedia session (video) can be transferred seamlessly. Secondly, the original MIH scheme is coupled with a novel mechanism that updates the video encoding parameters in real time, allowing video QoS adaptation and/or video QoS based vertical handover based on an estimated value of the current Peak Signal to Noise Ratio received by the mobile user. The simulation results carried out with the NS-2 tool parametrized for supporting MIH functionality and H.264 encoded video traffic, have shown a significant improvement both in the received video QoS in terms of PSNR and the network throughput, during WiFi to UMTS handover, under the proposed scheme.

## Keywords

802.21, MIH, vertical handover, QoS, PSNR, RTCP-XR

## 1. INTRODUCTION

<sup>\*</sup>Corresponding author

Permission to make digital or hard copies of all or part of this work for personal or classroom use is granted without fee provided that copies are not made or distributed for profit or commercial advantage and that copies bear this notice and the full citation on the first page. To copy otherwise, to republish, to post on servers or to redistribute to lists, requires prior specific permission and/or a fee.

*MobiMedia '09*, September 7-9, London, UK

Copyright 2009 ICST 978-963-9799-62-2/00/0004 ...\$5.00.

One of the main trends in the mobile communications sector is the connected everywhere, anytime, anyhow philosophy. This philosophy is also denominated Always Best Connected (ABC) philosophy [2]. It is based on the facts that several “competing” Radio Access Technologies (RATs) can co-exist, which have different requirements and capabilities. For an advanced scenario these RATs can range from existing technologies (e.g. UMTS, WiMAX) to future networks [4]. It is then necessary to have mechanisms that, for a particular instant in time, select the “best” network and perform the inter-working between different technologies. Therefore, it is important to define the framework that will allow mobility protocols to handle ongoing session and demanding services uniformly among heterogeneous link-layer interfaces. Interoperability and cooperative control of provided services are the key factors during the handover procedure of a Mobile Terminal (MT). Media Independent Handover (MIH) mechanism will handle the upcoming challenges of seamless mobility and session continuity at the middleware service platform. IEEE Working Group has recently proposed IEEE 802.21 standard [11] to enable handover and interoperability between heterogeneous networks with context-awareness in mobile terminals.

The major disadvantages of existing mobility solutions are, that they consider link-layer and network layer triggers in order to carry-out handover. They do not capture the application-related QoS requirements in order to support session continuity and maintain QoS of on-going sessions. An extensive overview of the key elements that are proposed in IEEE 802.21 standard, is included in [5]. The study focuses on the architecture and the services proposed in MIH. In [13] a MIH based vertical handover solution is presented. Although, a number of novel network entities that assist on the handover performance, which is carried out by the Mobile IP, are proposed, the study does not consider application specific requirements. Seamless mobility using 802.21 is also the focus in [7], which suggests a number of modification to be made on the underlying access networks in order to facilitate the MIH functionality. The reduction of the handover latency is the aim in [9]. This is achieved by specific link layer triggers that indicate the exact handover performance time to the handoff algorithm. A WLAN-

WMAN interworking framework that was presented in [3], proposed a number of extensions to the MIH, including a network selection function, a handover monitor and a novel module for QoS adaptation. Moreover, [15] proposes extensions to the MIH framework that include link, network and application layer information from both the client and the network sides, however, the authors suggest that a QoS adaptation to the new access network requirements will only take place after the execution of the handoff. A scheme for adapting the video codec in order to improve the performance during handoffs, is presented in [8].

Unlike previous research works on mobility using the MIH concept [10], the main emphasis of this work is that it takes into consideration application oriented parameters and investigates the impact of MIH at the perceived QoS and the handoff latency. The proposed MIH architecture acts as middleware mediator by collecting statistics from different layers. These parameters are imported in the decision handover algorithm that determines where on going session should be handed off by taking into account various cost parameters. Simulation results have been carried out between UMTS and WLAN in order to measure the performance of the proposed middleware architecture and test its impact on the perceived QoS.

The rest of the paper is organized as follows. Section 2 presents briefly the key elements of the MIH framework as proposed in [11]. The proposed enhancements, including the application layer specific parameters and the handoff functionality are analyzed in Section 3. The system architecture is presented in Section 4 along with the simulation setup and a discussion of the simulation results. Finally, Section 5 concludes the paper.

## 2. MEDIA INDEPENDENT HANDOVER – 802.21 FRAMEWORK

The IEEE 802.11 standard aims to enable handovers between heterogeneous technologies including WLAN, 3G and other wireless access technologies without service interruption, hence improving the user experience. Contrary to the current functionalities that provide service continuity with the cost of complex interactions specific to each particular technology, IEEE 802.21 provides a framework that ensures simplified interactions among higher and lower layers for achieving session continuity independently of the underlying technologies.

In particular, the 802.21 framework primary intention is to enable seamless handoff and interoperability between heterogeneous network types. This is done by introducing the layer 2.5 specified by Media Independent Handoff Function (MIHF) which provides three principal functionalities: Media Independent Events Service (MIES), Media Independent Command Service (MICS) and Media Independent Information Service (MIIS). The interactions among lower and upper layers and the role of the MIH functions are illustrated in Fig.1.

The MIES detects and delivers triggers from both local and remote interfaces corresponding to dynamic changes in link characteristic, status and quality. The current 802.21 specification defines events that may be relevant to handover decision, which may originate from any layer (PHY, MAC or MIH) either at the mobile terminal or the network point of attachment (PoA). MIES is responsible to trace any change in physical, network or application parameters that possible affect the ongoing session. When such changes are detected, MIES creates the appropriate triggers to the MIH function that resides in the MIH server. Since this study focuses primarily in a heterogeneous wireless network environment, a hierarchical structure of decision factors, each of which has a related trigger event, is proposed and will be further analyzed in the

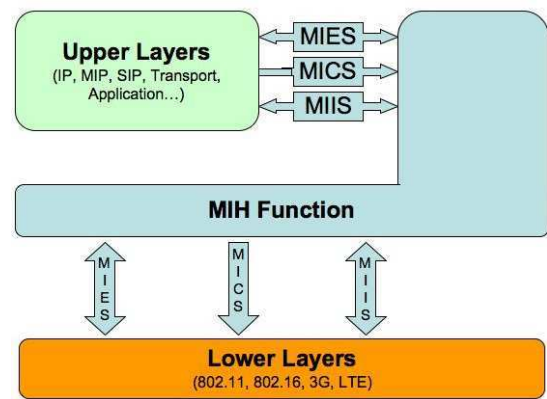

Figure 1: Layer interactions via MIH key functions

following section.

The MICS enables higher layers to control lower layers (physical, link layer). Higher layers may control the reconfiguration or selection of an appropriate link through a set of handover commands. The mobility management protocols combine dynamic information regarding link status and parameters, provided by the MICS with information regarding network status or other higher-layer service information provided by the MIIS, in order to assist the decision making. MIH commands can be both local and remote. The commands instruct a MIH device to poll connected links to learn the most recent status, to scan for newly discovered links, to configure new links and to switch between available links. All commands are designed to help in the handover procedure, but the routing of user packets is left to the mobility management protocols located at higher layers, like Mobile IP or SIP.

Finally, MIIS provides a framework and the corresponding mechanisms for discovering and obtaining information of existing networks able to facilitate handovers. The MIIS provides link layer parameters such as channel information, MAC address and security information of each point of attachment.

## 3. NOVEL ENHANCEMENTS ON MIH

The current 802.21 specification explicitly defines events related to the handover decision, which originate from the PHY, MAC and application layers, either at the mobile terminal or the network side. However, service continuity in the case of multimedia streaming and video in particular, requires also information that originates from higher layer. Thus, a vertical handover from 3G to WLAN, during a video session, can be triggered by an application layer event, such as a perceived QoS deterioration, or the need of higher video transmission bit rate. This paper proposes an enhanced MIH framework that takes into consideration these application initiated trigger events combined with other events relevant to the user context (i.e. QoS guarantees, equipment restrictions, charging policies, security policies) and lower layer originated events (i.e. SNR, packet loss, delay, jitter, etc.) during the handover decision. This section includes an analysis of the events that trigger a vertical handover and presents in details the proposed vertical handover decision algorithm. Particular focus is given to the perceived quality of video service in terms of PSNR and how the estimation of the PSNR value in real time may trigger the handover decision.

### 3.1 Application specific enhancements

All trigger events that are defined in the enhanced MIH framework can be categorized in three main groups namely, Link Information, Application QoS and Network Context. The source of these events may be the mobile terminal or the network point of attachment. From the network side, a set of information messages carried by MIIS is defined, which include the value of specific parameters such as, the list of available networks, the IDs of the cells, or the APs. The enhanced MIH based handover decision considers the list of authorized users, the target QoS parameters for on-going sessions, the number of connections per PoA, as well as, the uplink and downlink load factor for each cell and last but not least the available bandwidth. On the other hand, the proposed MIH framework defines trigger messages that originate from the MT. These messages include parameters such as, the discovered networks, the context transfer parameters, as well as, a set of PHY and network QoS parameters and informations regarding the MT's current location.

An important improvement to the standard 802.21 MIH framework, proposed in this paper is the use of the estimated PSNR (EPSNR) as a vertical handoff trigger. The calculation of the value of EPSNR requires the knowledge of parameters from different layers, the packet loss, the delay, and the available network capacity. Thus, it is also important to define a mechanism of collecting these informations from both the application server and the mobile user. Analytically, the main purpose of IEEE 802.21 is to enable handovers across inter-technology wireless networks without service interruption, hence improving the user experience of mobile terminals. However, multimedia applications that comprise of audiovisual context (IPTV, video streaming, VoIP, etc.), are very sensitive to the impairments of the wireless access channel and the IP core. Therefore, a fairly accurate mechanism of calculating the perceived by the user QoS, which is also relative simple to implement for large scale deployments, is proposed as an enhancement to the MIH framework. The proposed mechanism is based on the RTP Control Protocol Extended Report (RTCP-XR) as defined in [6]. In particular, XR packets convey information beyond that already contained in the reception report blocks of RTCP's sender report (SR) or Receiver Report (RR) packets.

In particular, the Real-time Transport Protocol (RTP) and RTP Control Protocol (RTCP) communications use the RTCP Receiver Report to feedback IP network conditions from RTP receivers to RTP senders. However, the original RTCP provides overall feedback on the quality of end-to-end networks as a whole [12]. The RTP Control Protocol Extended Reports (RTCP-XR) is a new VoIP and video streaming management protocol which defines a set of metrics that contains information for assessing the multimedia application quality. The RTCP-XR can be implemented as software integrated into IP mobile terminals and gateways inexpensively and then, messages containing key call-quality-related metrics are exchanged periodically between IP MTs and application servers.

The MIH functionality that resides in the MIH enabled MT requires the codec specifications, the video characteristics and the knowledge of the current conditions along the communication path, in order to be able to calculate the estimated perceived QoS. Therefore, the RTCP-XR block format includes all the appropriate parameter fields that the MT is required to fill in (i.e., q-step size, GOP, Distortion, etc.) This information is then fed back to the video streamer via the RTCP-XR and is used for the estimation of the perceived video quality as EPSNR. Upon calculating a EPSNR below a predefined threshold, the video streamer can adapt the encoding parameters (often this means changing the encoder's quantization-step) in order to gracefully adapt the video quality. This procedure is defined as video QoS adaptation and reduces sig-

nificantly the number of vertical handovers required during a video session. Nevertheless, QoS adaptation is limited by the predefined preferences of the client, in particular the minimum acceptable QoS level, which also limits the range of available Q-steps. If QoS adaptation is not an option any more, or if the user is roaming in different access networks, then a vertical handover is mandatory. In this case, the value of EPSNR, along with other PHY, Link layer and Network parameters, are collected and evaluated by the handover algorithm in order to determine whether a handoff is required or not.

It is evident that the calculation of PSNR is a key aspect of the proposed MIH based vertical handover algorithm. Therefore, a simple calculation method of the perceived video quality, proposed in [14] is adopted. The following analysis considers a video sequence that begins with an  $I$ -frame and is followed by  $P$ -frames with an intra frame period  $N$  in order to increase the error resilience of the video frames. It is assumed that this intra frame period equals to the total error recovery period, in case of packet loss. As an effect, losses that occur outside this period are uncorrelated. Let  $k$  be the index of video frame. Then the total increase in distortion that will affect the video if picture  $k$  is lost is given by:  $D(k) = \sum_{i=1}^L \Delta d_i$ , where  $L$  is the number of video frames in the sequence and  $\Delta d_i$  is the increase in the distortion, relative to frame  $i$ , given that picture  $k$  is lost. Due to specific error reduction schemes that are inherent into the encoding and decoding systems, the distortion effect on subsequent frames is reduced until it eventually becomes zero at a point far enough from frame  $k$ . Based on this definition the total video distortion due multiple lost frames  $M$  will be the sum of all individual distortions over all the frames  $L$  affected by these losses. The resulting total distortion at the decoder and the PSNR are

$$D_{total} = \sum_{j=1}^M D(j) = \sum_{j=1}^M \sum_{i=1}^L \Delta d_i(j) \quad (1)$$

$$PSNR = 10 \log \left( \frac{255^2}{D_{total}} \right)$$

### 3.2 Handover Function

The proposed handover function is an enhancement to the centralized MIH framework described previously. The process flow of the algorithm is illustrated in Fig.2. It can be seen that the vertical handover algorithm consists of four stages:

1. **Handover decision:** Initially, the MT related information, including SNR, delay, jitter, PSNR, packet loss, etc, are collected and sent to the MIH server via the MIIS. In addition, the MIIS is responsible of collecting corresponding information from neighboring networks, in order to be used during the handover decision making.
2. **Handover initiation:** These collected MIH parameters will be evaluated and compared against a set of predetermined threshold values. These thresholds are either determined by the network provider, (e.g. SNR) or the service provider (e.g. PSNR, media coding parameters), which are specified in each user's profile. The MIH event service, is responsible of comparing the collected statistics with the threshold values and inform the command service when one or more thresholds are violated and the handover criteria are matched. According to the proposed algorithm parameters from different layers (physical, data link, network and application) are considered throughout the handover decision. At this state, a

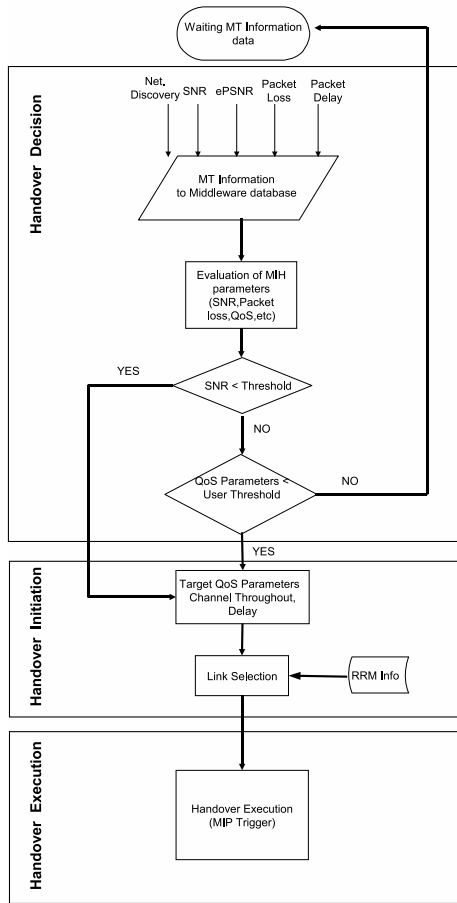

Figure 2: Proposed vertical handover algorithm

link selection module indicates the best candidate neighboring network for handoff according to specified target QoS parameters. The target QoS parameters are specified by the service provider according to the Quality of Service classification of the user (gold, silver, bronze).

3. **Handover execution:** The final stage is the execution of the vertical handover to the decided neighboring network. The Mobile IP platform is responsible of handling the vertical handover and of ensuring seamless service continuity.

The proposed vertical handover algorithm is modeled as a cost function that includes the rules and policies for selecting the best candidate network or for adapting the ongoing session parameters (increase QoS, reduce the number of handovers). The mathematical representation of the proposed handover cost function is as follows:

$$Q_i = f\left(\frac{1}{Q_i}, S_i, \frac{1}{P_i}, D_i, F_i\right) \quad (2)$$

$$= f\left(\omega_c \frac{1}{Q_i}, \omega_s S_i, \omega_p \frac{1}{P_i}, \omega_d D_i, \omega_f F_i\right)$$

This mathematical representation of the vertical handover function indicates that the decision for a handoff is based on the charging of the ongoing services ( $C_i$ ), the security scheme of current and candidate networks ( $S_i$ ), the QoS parameters ( $P_i$ ) and the condi-

tions ( $D_i$ ) and performance of home and candidate networks ( $F_i$ ). The service charging factor considers both the traffic class of the service (streaming, voice, data transfer, etc.) and the charge of roaming between heterogeneous networks. Moreover, security factor depends on whether authentication and end-to-end security is supported according to user-service provider preferences. The QoS factor depends on available quality information such as PSNR, R-Factor and jitter. Bandwidth availability, load and packet losses determine the network condition and network performance factors. In the context of this study, the security and the service charging factors are not under consideration. These parameters are the focus of future investigation as they demand more complex models and mathematical concepts, which are out of this paper's scope.

#### 4. SYSTEM ARCHITECTURE

This section presents the system architecture that is proposed in order to test the vertical handover using 802.21 framework. This architecture has been implemented using an heterogeneous network environment of 802.11 and UMTS networks. In addition, specific performance issues has been studied in order to evaluate the capabilities of the testing platform.

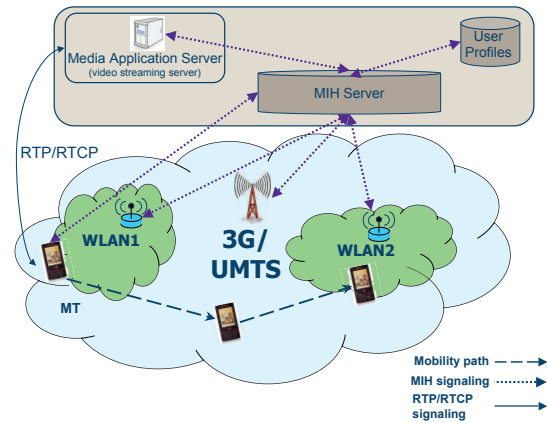

Figure 3: MIH system architecture

##### 4.1 System Architecture

The deployment of the enhanced vertical handoff based on 802.21 framework necessitates the development of a centralized unit that will assist the unified management of integrated mobile services over different access networks. The general system architecture that represents this concept, is illustrated in Fig.3. It is comprised of the network access entities, mobile terminals and access stations (e.g. access points, base stations), and the core network, which includes the media independent functionality.

The proposed architecture comprises of two 802.11e hotspots that are fully overlapped by a 3G/UMTS cell. The core network includes the media application servers, in addition to a middleware platform where the MIH functionality and the handover scheme reside. The media application servers provide real-time video streaming services to the mobile terminal and are capable to encode and transcode raw/compressed video according to the H.264/Advanced Video Codec standard. Moreover, the media servers implement the RTCP protocol with the extended report extension (RTCP-XR) in order to establish two-way RTP control signaling with the MT. The RTCP-XR report packet contains information regarding PHY and

Network layer statistics and it is responsible of notifying the MT in case of a change in the video encoding parameters. A key element of the proposed architecture is the middleware platform, which is responsible for the interoperability, control and provisioning of uninterrupted services to the underlying radio access networks and the IP layer. The MIH framework that is located at the central unit manages the ongoing sessions, based on the feedback that receives from the Remote Access Points (RAPs) or the MTs. Most importantly, the central unit hosts the proposed vertical handover decision algorithm, which evaluates the collected parameters from across different layers and firstly, determines whether a handover between WiFi and UMTS, or vice versa, is necessary and will improve the perceived video quality, secondly, triggers an underlying Mobile IP platform that is responsible for performing the vertical handoff. As a result, the proposed handoff functionality ensures seamless mobility and uninterrupted service provision by guaranteeing the QoS requirements of the video service before, during and after a vertical handoff. The middleware platform utilizes all MIH services defined in 802.21 standard, in order to connect to the MT.

## 4.2 Performance Evaluation

The performance of the proposed enhanced MIH framework was evaluated using NS-2 network simulation tool with extensions for MIH, 802.11e, and UMTS models. The network topology comprises of one 3G cell, two WLAN APs, one MT, a video server and a MIH enabled core network according to Fig.3. For the purpose of the simulation a YUV Quarter Common Intermediate Format (QCIF) 4:2:0 color video sequences consisting of 300 and coded at 30 frames per second are used as video source. Each group of pictures (GOP) is structured as *IPPPPPP* and contains 12 frames, and the maximum UDP packet size is at 1024 bytes (payload only). The H.264/MPEG-4 AVC encoder provided by [1] is used for encoding YUV sequences. The testing video sequence is encoded at 512 kbps. Each video frame can be conveyed into more than one RTP packets, thus a lost packet due to channel or network impairments will not necessarily cause the whole frame to be lost. The size of each RTP packet is maximally bounded to 1024 bytes. In order to stretch the system's capacity, a number of background nodes are transmitting CBR traffic at an aggregate rate of 300 kbps for the UMTS system and 2 Mbps for the WLAN.

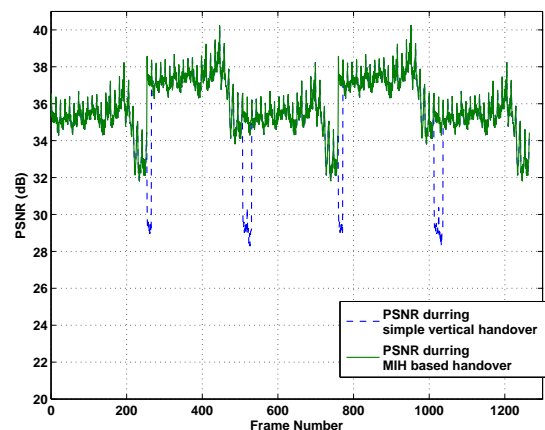

**Figure 4: Measured throughput achieved with the proposed handoff framework**

In order to demonstrate the ability of the proposed extended MIH scheme to maintain connection continuity and achieve better per-



**Figure 5: Measured throughput achieved with a simple vertical handoff**



**Figure 6: Perceived video quality in terms of PSNR during vertical WLAN-UMTS handover.**

formance (higher video throughput and better perceived video quality, in this case) than a traditional vertical handoff scheme, the following experiment was set up. The network setup for the experiment is shown in Fig.3. Specifically, there are two 802.11e APs with an available capacity of 5 Mbps each and a UMTS network with a maximum of 384 kbps transmission service rate. The MT includes an IEEE 802.11e WLAN and an UMTS interface, hence can maintain connectivity with both access networks simultaneously, while it is moving slowly at a speed of 1 m/s. In order to stretch the load of the networks a number of additional wireless nodes are used that transmit CBR TCP traffic at 2 Mbps in the WLAN network and 300 kbps in the UMTS network.

For comparison, a traditional simple vertical handoff scenario is implemented. The simple vertical handoff algorithm is based on the principle that a WLAN network is a better candidate network than a UMTS, in the case of a video communication. According to this simple scenario, a handoff from UMTS to WLAN will be triggered as soon as, the existence of a candidate WLAN AP becomes known to the MT. On the other hand, when the MT losses connection with its AP, it will initiate a network scanning process until another WLAN, or UMTS network becomes available.

In Fig.4 and 5, the network throughput achieved by the proposed and the simple scenarios, are illustrated respectively. Specifically, four handoffs are demonstrated during a 300 seconds simulation time. The MT is firstly connected to the UMTS network, hence the video throughput is limited by the maximum UMTS available transmission rate. The proposed scheme achieves a lower handoff delay, as shown at simulation time 150 seconds, during a WLAN to UMTS handover. It is evident that in the simple scenario, the MT during the WLAN to UMTS handoff, experiences a large handoff delay due to the network scanning procedure. On the other hand, the proposed scheme, based on the handoff functionality and the MIH services, is able to reduce the handoff time by 37% during a WLAN to UMTS handover and by 20% during a UMTS to WLAN handoff. In addition, Fig.6 illustrates a comparison of the achieved PSNR by the two handoff schemes. It can clearly be seen that the proposed MIH based handover improves the perceived video quality by almost 3 dB, in terms of PSNR, during the handover phases. This improvement is the result of lower handover latency and the resulting fewer packet losses, achieved by the proposed scheme, during the vertical handoff.

## 5. CONCLUSIONS

In conclusion, this presents an enhanced MIH framework for supporting multimedia services continuity across inter-technology access networks. Unlike previous research works on mobility using the MIH concept, this paper proposes a set of enhancements on the standard IEEE 802.21, which include application oriented parameters and investigates the impact of MIH at the perceived QoS, the throughput and the handoff latency. A novel handover decision function based on triggering/collecting statistics from physical, network and application layer, so that an ongoing multimedia session (video) can be transferred seamlessly, is proposed. The original MIH scheme is coupled with a novel mechanism that updates the video encoding parameters in real time, allowing video QoS adaptation and/or video QoS based vertical handover based on an estimated value of the current PSNR received by the mobile user. The simulation results indicate that the proposed enhanced MIH framework achieves a lower latency during a UMTS-WLAN and WLAN-UMTS handoff of 20% and 37%, respectively, compared to a traditional simple scenario. Moreover, the proposed scheme succeeds on improving the perceived video quality by 3 dB during the handoff.

## Acknowledgment

Part of this work was supported by the European Commission under Grant Agreement No.215533 (FUTON: Fiber Optic Networks for Distributed, Extendible Heterogeneous Radio Architectures and Service Provisioning), FP7, ICT-1-1-1 Activities (Network of the Future).

## 6. REFERENCES

- [1] H.264 reference software version. *Fraunhofer Institute, Image Processing Department, available from <http://ip.hhi.de>.*
- [2] I. Akyildiz, J. Xie, and S. Mohant. A survey of mobility management in next-generation all-ip based cellular systems. *IEEE Wireless Communications*, 11(4):16–28, August 2004.
- [3] T. Ali-Yahiya, K. Sethom, and G. Pujolle. A case study: Ieee 802.21 framework design for service continuity across wlan and wman. In *IFIP International Conference on Wireless and Optical Communications Networks, WOCN '07.*, pages 1–5, July 2007.
- [4] D. Bourse and R. Tafazolli. Beyond 3g / 4g radio access technologies (rats) and standards roadmaps. *eMobility Technology Platform Whitepaper*, Version 1.0:1–41, December 2007.
- [5] A. De La Oliva, A. Banchs, I. Soto, T. Melia, and A. Vidal. An overview of ieee 802.21: media-independent handover services. *IEEE Wireless Communications*, 15(4), August 2008.
- [6] draft-ietf-avt-rtcpvr-video-00.txt IETF. Rtcp xr video metrics. Technical report, IETF, <http://www.ietf.org/internet-drafts/draft-ietf-avt-rtcpvr-video-00.txt>.
- [7] L. Eastwood, S. Migaldi, Q. Xie, and V. Gupta. Mobility using ieee 802.21 in a heterogeneous ieee 802.16/802.11-based, imt-advanced (4g) network. *IEEE Wireless Communications*, 15(2):26–34, April 2008.
- [8] B. Kim, S. Seo, and J. Song. An effective codec adaptation for mih based vertical handover in heterogeneous wireless networks. In *International Symposium on Information Science and Engineering, ISISE '08.*, volume 2, pages 80–83, December 2008.
- [9] J.-M. Kim and J.-W. Jang. Low latency vertical handover using mih l2-trigger algorithm in mobile ip networks. In *Proceedings of the 5th international symposium on Parallel and Distributed Processing and Applications*, volume 4742, pages 707–718. Springer-Verlag, 2007.
- [10] G. Lampropoulos and N. Passas. Media-independent handover for seamless service provision in heterogeneous networks. *IEEE Communications Magazine*, 46(1):64–71, January 2008.
- [11] P802.21/D10.0. Ieee draft standard for local and metropolitan area networks: Media independent handover services. Technical report, IEEE, April 2008.
- [12] H. Schulzrinne, S. Casner, R. Frederick, and V. Jacobson. Rfc 3550 rtp: A transport protocol for real-time applications. Technical report, The Internet Society, July 2003.
- [13] J.-H. Seol and J.-M. Chung. Ieee 802.21 mih based handover for next generation mobile communication systems. In *4th International Conference on Innovations in Information Technology, IIT '07.*, pages 431–435, November 2007.
- [14] K. Stuhlmuller, N. Farber, M. Link, and B. Girod. Mobility using ieee 802.21 in a heterogeneous ieee 802.16/802.11-based, imt-advanced (4g) network. *IEEE J. Selected Areas in Communications*, 18(6):1012–1032, June 2000.
- [15] W. Ying, Z. Yun, Y. Jun, and Z. Ping. An enhanced media independent handover framework for heterogeneous networks. In *IEEE Vehicular Technology Conference, VTC Spring 2008*, pages 2306–2310, May 2008.