

Efficiency and Effectiveness of a Fin Having Capsule-Shaped Cross Section Dependent on the One-Dimensional Position

1st Kevin Sebastian Ginting¹, 2nd st Petrus Kanisius Purwadi², 3rd st Sudi Mungkasi³
{sebastianginting@gmail.com¹, pur@usd.ac.id², sudi@usd.ac.id³}

Sanata Dharma University, Yogyakarta, Indonesia¹²³

Abstract. In this paper, we investigate the efficiency and effectiveness of a special form of fin to accelerate heat transfer in a system when the state is unsteady. The fin has capsule-shaped form in its cross sections. The area of the cross section is dependent on its one-dimensional position. The closer the position to the heat source, we have that the area of the fin cross section is larger. The further the position from the heat source, we have that the area of the fin cross section is smaller. The aim of the research is to investigate the influence of the convection heat transfer coefficient, fin material, and fin slope to the efficiency and effectiveness of fin in the unsteady state condition. In the heat transfer within the fin, we assume that the conduction heat transfer coefficient is dependent on the temperature. The solving method is an explicit finite difference method. We obtain three findings for unsteady state conditions. First, the larger the convection heat transfer coefficient, we have that the smaller the efficiency and the effectiveness of the fin. Second, in the unsteady state condition, the materials influence the efficiency and effectiveness of the fin in an unstructured way. Third, when we observe the influence of fin slope of angles 1.5o, 1.75o, 2o, 2.25o, and 2.5o, we obtain that the fin slope of angle 2.5o leads to the worst efficiency, and the effectiveness gets smaller with respect to time.

Keywords: one-dimensional; conduction heat transfer; fin material, and fin slope to the efficiency

1 Introduction

Heat transfer is very important in a mechanical system so that the system is not overheating [1]. Therefore, the system is usually equipped with fins to accelerate heat transfer[2],[3]. Fins are usually added in computer processors, fuel motor cylinders, and heat exchangers. Fuel motor cylinders needs fins in order to maintain the temperature in the cylinders. To optimize the heat transfer, we need to study the efficiency and effectiveness of the added fins. Efficiency is the ratio between the actual heat being released by fins and the ideal heat that can be released if all parts of fins have the same temperature as their bases. Effectiveness is the ratio between the actual heat being released by fins and the actual heat being released without fins.

In the steady state, literature shows some graphical relations between efficiency (η) and ξ (ξ), where $\xi = Lc3/2(hk/Am)1/2$ [4].

. Here L_c represents the corrected length of fin, h denotes the convection heat transfer coefficient, k denotes the thermal conductivity, and A_m represents the profile area of the fin. Some forms of fins can be found in the book of Holman [2]. The present research question is what if the state is unsteady. How the efficiency and effectiveness behave is our focus in this paper.

In this paper we consider a capsule-shaped fin, as shown in Figure 1. The cross sectional area is dependent on the one-dimensional position x . The thermal conductivity is assumed to be dependent on the temperature ($k = k(T)$). We limit our discussion for unsteady state conditions.

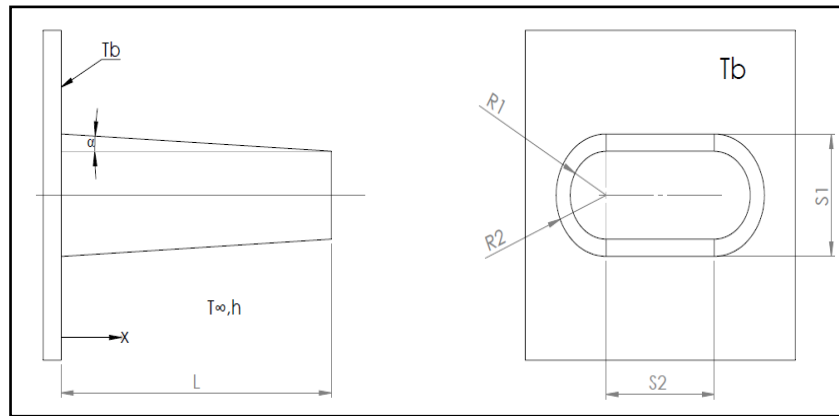

Figure 1. Illustration of a capsule-shaped fin

Figure 1 illustrate a geometrical interpretation of the capsule-shaped fin. The cross sectional area changes with respect to the position x . S_1 is the height of the fin at the base position. S_2 is the length of the horizontal part at the base position of the fin. Here we assume that $S_1 = S_2$. R_1 is the radius of the fin at the end-position. R_2 is the radius of the fin at the base-position. L is the length of the fin. α is the angle of the fin (fin slope). The goal of the research is to investigate the efficiency and effectiveness influenced by: (a) the convection heat transfer coefficient h , (b) materials of the fin, and (c) fin slope α .

1. Research methodology

In this section we provide our research methodology including the step by step for efficiency and effectiveness of the fin in the unsteady state condition as well as the numerical models that we use.

To obtain the efficiency and effectiveness of the fin, we use the following steps:

1. Find the value $k=k(T)$ for each material of the fin.
2. Calculate the temperature in the discrete positions.
3. Calculate the heat transfer including the actual, the ideal, and the base heat transfers.
4. Calculate the efficiency of the fin.
5. Calculate the effectiveness of the fin.

The discrete positions are related to the control volumes, as shown in Figure 2. Initially, we assume that the temperature is the same at all positions.

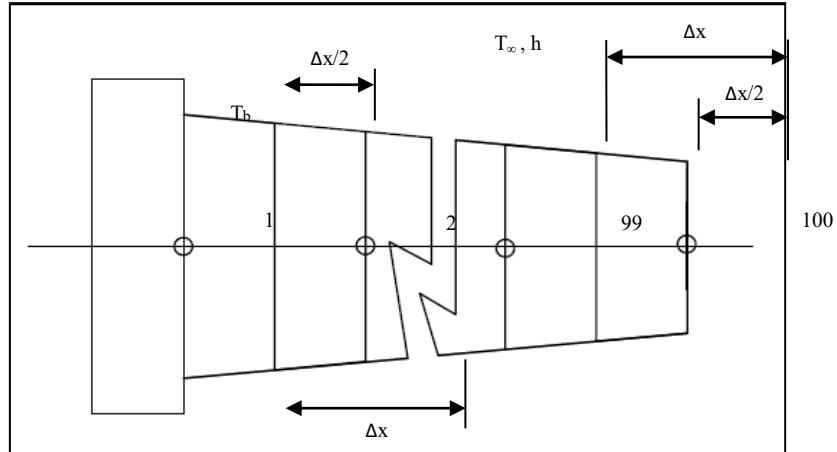

Figure 2. Illustration of the fin control volume

The mathematical equation for calculating the temperature at each discrete position is derived from the conservation energy principle in the control volume, as follows. Let

$$\begin{aligned} E_{in} + E_g &= E_s + E_{out} \\ (E_{in} - E_{out}) + E_g &= E_s \end{aligned} \quad (2)$$

Here E_{in} is the incoming energy, E_{out} is the outgoing energy, E_g is the generated energy, and E_s is the stored energy in the control volume. In addition, at $i = 1$, that is at the base control volume, the temperature is fixed to be:

$$T_i^{n+1} = T_b \quad (3)$$

Here we assume that $E_g = 0$, and T_b is the temperature at the base of the fin. The initial temperature on the whole fin is assumed to be equal to T_b . Based on the conservation energy principle, the temperature of the control volume inside the fin (not the base and not the end control volume) is calculated as follows:

$$T_i^{n+1} = \frac{\Delta t}{\rho c \Delta x V_i} \left[k_{i-\frac{1}{2}}^n \cdot A_{i-\frac{1}{2}} (T_{i-1}^n - T_i^n) + k_{i+\frac{1}{2}}^n \cdot A_{i+\frac{1}{2}} (T_{i+1}^n - T_i^n) + h A_{si} \Delta x (T_\infty - T_i^n) \right] + T_i^n$$

The stability condition for the explicit finite difference numerical method (4) is:

$$\Delta t \leq \frac{\rho c V_i \Delta x}{\left(k_{i-\frac{1}{2}}^n A_{i-\frac{1}{2}} + k_{i+\frac{1}{2}}^n A_{i+\frac{1}{2}} + h \Delta x A_{si} \right)} \quad (5)$$

Again, based on the conservation energy principle, the temperature of the control volume at the end of the fin is:

$$T_i^{n+1} = \left[\frac{\Delta t}{\rho c \Delta x V_i} \left(k_{i-\frac{1}{2}}^n A_{i-\frac{1}{2}} (T_{i-1}^n - T_i^n) + h A_i \Delta x (T_\infty - T_i^n) + h A_{si} \Delta x (T_\infty - T_i^n) \right) \right] + T_i^n$$

The stability condition of the explicit finite difference method (6) is:

$$\Delta t \leq \frac{\rho c V_i \Delta x}{\left(k_{i-\frac{1}{2}}^n A_{i-\frac{1}{2}} + h \Delta x A_i + h \Delta x A_{si} \right)} \quad (7)$$

Note that in the computation, the stability condition (5) and (7) must be fulfilled.

The variables in equations (3), (4), (5), (6), (7) are described as follows:

T_i^{n+1} : the temperature at the control volume at the i position for the $n + 1$ iteration ($^{\circ}\text{C}$ unit)

T_i^n : the temperature at the control volume at the i position for the n iteration ($^{\circ}\text{C}$ unit)

T_{i+1}^n : the temperature at the control volume at the $i + 1$ position for the n iteration ($^{\circ}\text{C}$ unit)

T_{i-1}^n : the temperature at the control volume at the $i - 1$ position for the n iteration ($^{\circ}\text{C}$ unit)

T_∞ : the temperature at the neighborhood of the fin ($^{\circ}\text{C}$ unit)

T_b : the temperature at the base of the fin ($^{\circ}\text{C}$ unit)

Δt : time step (s unit)

Δx : the distance between the consecutive centroids of control volumes (m unit)

$k_{i-\frac{1}{2}}^n$: thermal conductivity at the $i - \frac{1}{2}$ position for the n iteration ($\text{W}/\text{m}^{\circ}\text{C}$ unit)

$$\approx \frac{k^n (T_i^n) + k^n (T_{i-1}^n)}{2} \approx k^n \left(\frac{T_i^n + T_{i-1}^n}{2} \right)$$

$k_{i+\frac{1}{2}}^n$: thermal conductivity at the $i + \frac{1}{2}$ position for the n iteration ($\text{W}/\text{m}^{\circ}\text{C}$ unit)

$$\approx \frac{k^n (T_{i+1}^n) + k^n (T_i^n)}{2} \approx k^n \left(\frac{T_{i+1}^n + T_i^n}{2} \right)$$

h : convection heat transfer coefficient ($\text{W}/\text{m}^2\text{C}$ unit)

- $A_{i-\frac{1}{2}}$: cross section area of the control volume of the fin at the $i - \frac{1}{2}$ position
(m² unit)
 $A_{i+\frac{1}{2}}$: cross section area of the control volume of the fin at the $i + \frac{1}{2}$ position
(m² unit)
 A_{si} : surface area of the control volume of the fin at the i position (m² unit)
 ρ : density of the fin material (kg/m³ unit)
 c : specific heat of the fin material (J/kg°C unit)
 V_i : the volume of the control volume of the fin at the i position (m³ unit)

Efficiency (η) of the fin is the ration between the actual heat being released by fins and the ideal heat that can be released if all parts of fins have the same temperature as their bases [5]. The maximum of the heat that can be released by the fin can be obtained if the whole fin has the same temperature as the base of the fin. Therefore, the efficiency of the fin is defined by:

$$\eta^n = \frac{\sum_{i=1}^m (A_{si}(T_i^n - T_\infty))}{\sum_{i=1}^m A_{si}(T_b - T_\infty)} \quad (8)$$

Here we note that the value of h influences the temperature, so the value of h influences the efficiency of the fin. This is implicitly stated in equation (8). In this equation, the variables are described as:

- η^n : efficiency of the fin at the n iteration
 m : the number of control volumes
 T_i^n : the temperature of control volume at the i position at the n iteration (°C unit)
 A_{si} : the surface area of the control volume at the i position (m² unit)

Effectiveness (ε) of the fin is the ratio between the actual heat being released by fins and the actual heat being released without fins [1]. Effectiveness of the fin is defined by:

$$\varepsilon^n = \frac{h \sum_{i=1}^n (A_{si}(T_i^n - T_\infty))}{hA_d(T_b - T_\infty)} \quad (9)$$

where in this equation, the variables are described as:

- ε^n : effectiveness of the fin at the n iteration
 A_d : the cross sectional area of the fin at the base, that is, position $x = 0$
(m² unit)

1. 1 Research object

The geometry of the fin is shown in Figure 1. The fin length is $L = 0.099$ m, where $S1$ and $S2$ are at the base of the fin equal to 0.01 m. The number of control volume is fixed to be 100 . The distance between consecutive centroids of the control volumes is $\Delta x = 0.001$ m. The time step is $\Delta t = 0.001$ s. The temperature at the base of the fin is fixed to be $T_b = 100^\circ\text{C}$. The

initial temperature of the fin is the same everywhere to be $T_i = 100^\circ\text{C}$. The temperature of the environment is fixed to be $T_\infty = 30^\circ\text{C}$.

For the variation of h value, we assume to use the material of the fin to be steel with the fin slope $\alpha = 20$. For the variation of the fin materials, we take $h = 250 \text{ W/m}^2\text{oC}$ and the fin slope $\alpha = 20$. For the variation of the fin slope α , we take $h = 250 \text{ W/m}^2\text{oC}$ and we use steel as our fin material.

1.2 Research variation

In our research we use variations as follows:

- $h = 25 \text{ W/m}^2\text{C}$, $100 \text{ W/m}^2\text{C}$, $250 \text{ W/m}^2\text{C}$, $500 \text{ W/m}^2\text{C}$, and $900 \text{ W/m}^2\text{C}$.
- fin materials are aluminium, copper, silver, iron, and steel. The properties of these materials are listed in Table 1.
- $\alpha = 1.5^\circ$, 1.75° , 2° , 2.25° , 2.5° .

Table 1. Properties of materials [2]

Materials	Temperature Interval ($^\circ\text{C}$)	ρ (kg/m^3)	c ($\text{J/kg}^\circ\text{C}$)	k function of temperature ($k = k(T)$) ($\text{W/m}^\circ\text{C}$)
aluminium (99,75%)	0-800	2700	900	$k = (0.0003T^2)+0.0074T+202.23$
copper (98,9%)	0-600	8900	390	$k = (0.00002T^2)-0.0622T+385.66$
silver (99,9%)	0-500	10500	230	$k = (6.10^{-7}T^3)-(10^{-4}T^2)-0.1811T+ 410.54$
iron (armc) (99,92%)	0-800	7900	450	$k = (0.00002T^2)-0.0706T+74.59$
steel (99,2% Fe;0,2C)	0-999	7800	450	$k = (-0.00002T^2)+0.0075T+45.852$

2. Results and discussion

The convection heat transfer coefficient h that is varied gives influence to the efficiency and effectiveness of the fin. The higher the value of h leads to the smaller the efficiency and effectiveness of the fin, as shown in Figures 3a and 3b. This is because the higher the value of h leads to the temperature distribution of the fin gets smaller. In other words, the temperature of the fin approaches the temperature of the environment. Therefore, the difference between the temperature of the the fin and the temperature of the environment is small.

Because of the definition of the efficiency, the actual heat transfer determines the value of the efficiency. We observe that the larger the convection heat transfer efficiency h results in small difference between the temperature of the fin and the temperature of the environment. Consequently, the actual heat transfer gets small too, so does the efficiency.

The same case for effectiveness, the convection heat transfer coefficient h that is large leads to small distribution of the temperature of the fin. In other words, it approaches the temperature of the environment, so the difference between the temperature of the fin and the temperature of the environment is small. Because of the definition of the effectiveness, the

actual heat transfer influence the effectiveness itself. That is, if the actual heat transfer is small, then the effectiveness gets small.

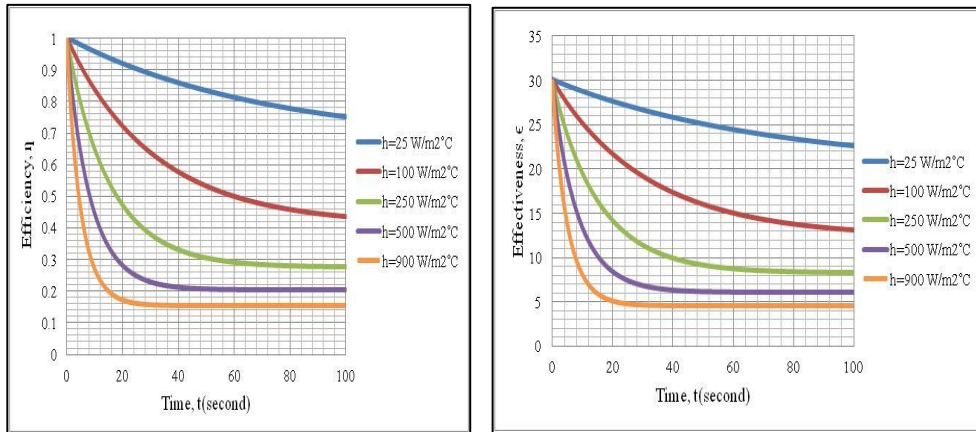

(a) (b)
Figure 3. (a) Efficiency and (b) effectiveness of the steel fin with respect to time with $\alpha = 2^\circ$, $T_\infty = 30^\circ\text{C}$, $T_i = 100^\circ\text{C}$, $T_b = 100^\circ\text{C}$

As illustrated in Figures 4a and 4b, we observe that the variation of the fin materials influences the efficiency and effectiveness of the fin. In the unsteady state condition, we have the following: the density ρ is constant, the specific heat c is constant, and the thermal conductivity of the fin material is dependent on the temperature. These all quantities influence the efficiency and effectiveness of the fin. At time 20 seconds of the simulation, the fin materials can be ordered based on the efficiency and effectiveness from high to low as follows: copper, silver, aluminium, iron, and steel. This order is the same until at time 30 seconds of the simulation. However, after 40 seconds of the simulation until the steady state condition is achieved, we can make an order of the fin materials having efficiency and effectiveness from high to low as follows: silver, copper, aluminium, iron, and steel.

In short, for the unsteady state condition, the order of the fin materials having efficiency and effectiveness from high to low can change. That is, this order is not fixed.

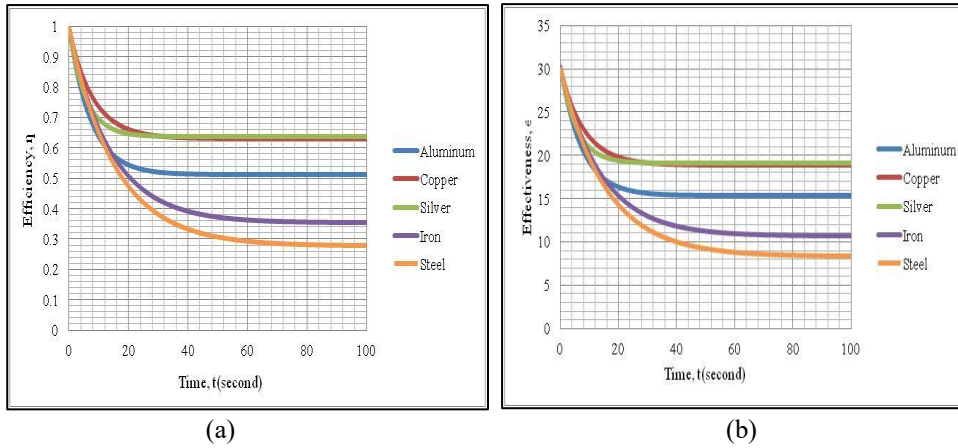

(a) (b)
 Figure 4. (a) Efficiency and (b) effectiveness of the fin with respect to time with $h = 250 \text{ W/m}^2\text{C}$, $\alpha = 2^\circ$, $T_\infty = 30^\circ\text{C}$, $T_i = 100^\circ\text{C}$, $T_b = 100^\circ\text{C}$

Based on Figures 5a and 5b, the fin slope also affects the efficiency and effectiveness of the fin. When the fin slope is large, the surface area of the fin is also large. This large surface area makes the heat transfer faster to approach the steady state condition. Therefore, the difference of the temperature of the fin and that of the environment is small. This results in the small heat transfer.

Based on the definition of the efficiency, the larger the surface area of the fin leads to the temperature distribution of the fin gets smaller. Therefore, the difference between the fin temperature and the environment temperature gets smaller too. The efficiency becomes smaller because of the surface area of the fin which is large.

According to the definition of the effectiveness, the effectiveness gets smaller with respect to the fin slope which gets smaller.

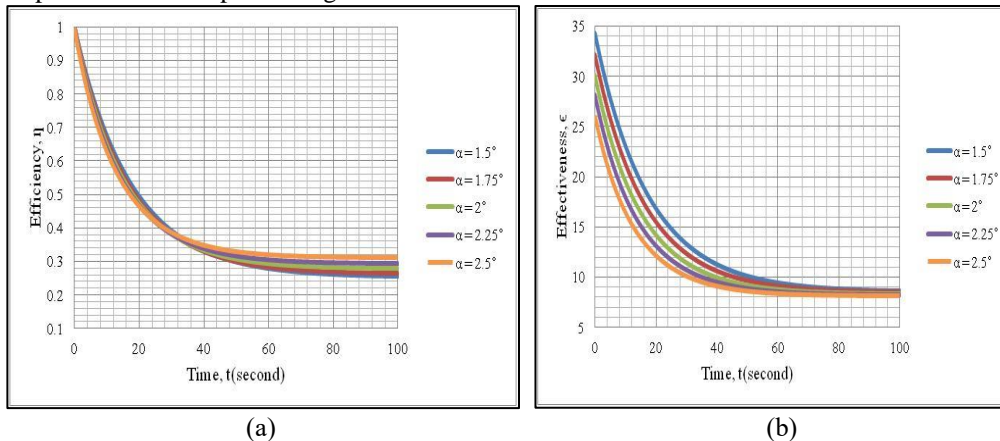

(a) (b)
 Figure 5. (a) Efficiency and (b) effectiveness of the steel fin with respect to time with $h = 250 \text{ W/m}^2\text{C}$, $T_\infty = 30^\circ\text{C}$, $T_i = 100^\circ\text{C}$, $T_b = 100^\circ\text{C}$

Conclusions

In this paper, we have presented our investigation about the influence of some variables to the efficiency and effectiveness of fins. We obtain that: a large convection heat transfer coefficient leads to small efficiency and effectiveness of the fin; for unsteady state conditions, the constant density, the constant specific heat, and the thermal conductivity dependent on temperature affects the efficiency and effectiveness of the fin; a large fin slope gives a small efficiency and a small effectiveness. Our research is limited to several convection heat transfer coefficients, several materials and several fin slopes. Future research could be an extension of these variations of coefficients, materials, and slopes.

Acknowledgements

This research was financially supported by Sanata Dharma University. The authors thank Sanata Dharma University for the financial support.

References

- [1] F. Ismail, Z. R, and A. M, Numerical investigation of turbulent heat convection from solid and longitudinally perforated rectangular fins”, *Procedia Engineering*. 2013.
- [2] T. D. Nugroho and P. K. Purwadi, “Fins effectiveness and efficiency with position function of rhombus sectional area in unsteady condition”, *AIP Conference Proceedings*,” 2016.
- [3] P. K. Purwadi, Efisiensi sirip berbentuk silinder”, *Mekanika*. 2010.
- [4] J. P. Holman, *Heat Transfer* (10th edition). McGraw-Hill, New York., 2010.
- [5] Y. A. Cengel, *Heat and Mass Transfer: A Practical Approach* (3rd edition. McGraw-Hill, New York., 2006.