

Control of energy efficient belt conveyor gearless drum-motor

I.Yu. Semykina^{1,*} and A.V. Tarnetskaya¹

¹T.F. Gorbachev Kuzbass State Technical University, 28 street Vesennyaya, Kemerovo, 650000, Russian Federation

Abstract

There is a tendency for simplifying the construction of gears. Many manufacturers design gearless electric drives for power mechanisms like traction. Rejection of mechanical transmission and replacing obsolete induction motor with energy-efficient permanent magnet synchronous machine allow to increase electric drive reliability, reduce repair and maintenance costs, also improve the technological process and industrial safety.

This article is devoted to questions of permanent magnet synchronous motor control for underground belt conveyor gearless drum-motor. The model of the electrical machine this type with special construction was created by finite elements method. In modeling, Infolytica MagNet and MotorSolve tools were used. The key thing is the special characteristics of high-torque slow-moving power machines was quantified by this modeling. The last section of the article contains the comparison of methods for high-torque slow-moving PMSM control. Finally, the simulation results for operating with vector control system is shown.

Keywords: high-torque high-efficient permanent magnet synchronous machine, finite elements modeling, electric drive control system, sensorless control.

Received on 15 June 2018, accepted on 12 October 2018, published on 31 January 2019

Copyright © 2019 I.Yu. Semykina *et al.*, licensed to EAI. This is an open access article distributed under the terms of the Creative Commons Attribution license (<http://creativecommons.org/licenses/by/3.0/>), which permits unlimited use, distribution and reproduction in any medium so long as the original work is properly cited.

doi: 10.4108/eai.13-7-2018.156435

*Corresponding author. Email: siyu.eav@kuzstu.ru

1. Introduction

The underground belt conveyors are the main type of equipment for delivering coal ore or other extracted raw materials from the underworkings. The energy consumption of equipment this type has a crucial impact on the power balance on the whole underground mine enterprise. Nowadays, in coalmine manufactures of Russia, the most of belt conveyor electric drives are non-regulated induction motor drives with hydraulic couplings. A gear system generally consists of worm and toothed gears. And this configuration of an energy-intense electric drive is a poorly performing one.

In traditional non-regulated induction motor drives constantly causes start-up and load-rejection overvoltages, high start-up currents and pulsating torque lead to additional tension and slippage of the belt. Therefore, total power

losses increase during to distribution of load, in speed regulation and steady-state operating modes. Mechanical transmission not only limits rotation power and reduces the efficiency of electric drive, but also has considerable dimensions. On top of all, the most expensive part of belt conveyor gear is coupling that easily becomes disabled because of fatigue damages [1].

In recent years, researchers and engineers all over the world commonly refuse to use traditional induction machines in the design of high-power electric drives, by reason of the inconsistency with new energy efficiency standards of IE. The modern researches have demonstrated that high-torque permanent magnet synchronous machines (PMSM) increasingly apply as electric machines of drum-motors in belt conveyor systems. There is also a tendency of replacing common power-drive station of belt conveyors with more producible drum-motors and introducing gearless electric drives with direct transmission of torque to the shaft

of controlled component. The preceding reasons allow confirming the urgency of this article and our research [2-6].

Developing of a high-torque slow-moving PMSM control system for gearless drum-motor needs to decide the next questions:

- (i) Design the high-torque slow-moving PMSM model using dimensions and parameters data of the electric drive of the actual underground belt conveyor.
- (ii) Select the control method on the assumption of the requirement for the belt conveyor control system.
- (iii) Simulate the slow-moving PMSM control system.

2. Development of high-efficient PMSM

2.1. Simulation by finite elements methods

In a gearless drive, a high-torque high-efficient permanent magnet synchronous machine is located inside a drum-motor. It should produce the required output power with needed mechanical torque and power factor and it has to fit the internal space of the drum-motor body. As a key sample, the electric drive parameters of the belt conveyor in “Taldynskaya-Kargaiskaya” coal mine (Russian Federation, Novokuznetsk) was chosen. They are the following: the drum width $l = 1.2$ m and the drum diameter $d = 1$ m; the supply voltage of induction motor with squirrel cage parameters $U_m = 6$ kV and its capacity $P = 680$ kW; the drum rotation velocity $n = 60$ rpm; the nominal torque $M_n = 110$ kNm.

The energy and mechanical characteristics of multipolar slow-moving PMSM depend on not only magnet systems materials and location of permanent magnets, furthermore on a magnetic angle, grooves the depth and magnitude of the tooth. High-torque high-efficient slow-moving permanent magnet synchronous machine has a rotor with radial surface magnets (magnetic flux produces on radial direction) and pole tips to provide uniform distribution of magnetic flux in the air gap and protect permanent magnets from demagnetization [7-9]. The rotor of PMSM must be thin and plate, the number of pole pairs $p \leq 12$ for creating high torque with desired magnitude [10].

The special software MotorSolve and Magnet environments by Infolytica that based on the finite elements method was used to development the PMSM with required characteristics. The finite elements method based on the principle of partition the area of solutions of differential and integral equations with partial differentials into a finite number of elements. The form of approximating function is selected for each element and the complexity of function depends on required accuracy. The parameters of the developed slow-moving PMSM is shown in Table 1.

Fig. 1 represents the distribution of electromagnetic flux in the magnetic conductor of slow-moving PMSM at the rated load. We can see that most of the magnetic field lines penetrate the tooth areas of stator core and magnitude of electromagnetic induction is high, that is shown as yellow and red areas in the fig. 1, because of the high coercive force

of permanent magnets. For these reasons, tooth material is strongly magnetized, in the air gap large number of upper harmonic occurs, and distribution of electromagnetic flux becomes unequal with peaks in the tooth areas.

Fig. 2 and Fig. 3 represent machine currents, power, losses, and torque versus rotor position angle relationship at rated stator current. All these characteristics, especially electromagnetic torque, have non-sinusoidal distribution. It explains by following factors.

Table 1. Parameters of the developed slow-moving PMSM

Parameter	Characteristics		
	Symbols	Unit	Value
Supply voltage in mining electric system	U	V	6000
Rated active power	P	kW	680
Active resistance of stator windings	R_s	Ω	2,367
Self-inductance of stator windings along d-axes	L_d	H	0,579
Self-inductance of stator windings along q-axes	L_q	H	0,496
Rated electromagnetic torque	T_e	Nm	110330
Flux produced by permanent magnets	Ψ_{PM}	Wb	52,49
Number of pole pairs	p_n	–	12
Rotor moment of inertia	J	kg·m	0,025
Power factor	$\cos\varphi$	–	0,72
Efficiency	η	%	93,8

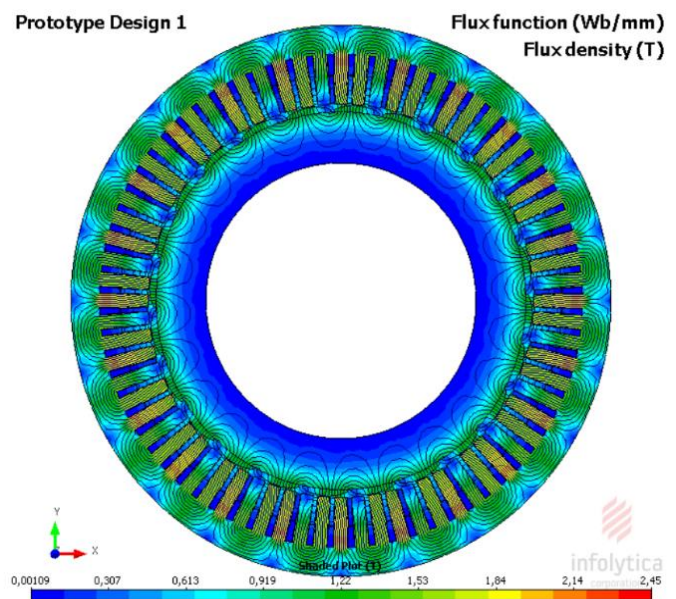

Figure 1. Distribution of electromagnetic flux

in the magnetic core of developed slow-moving PMSM at rated load

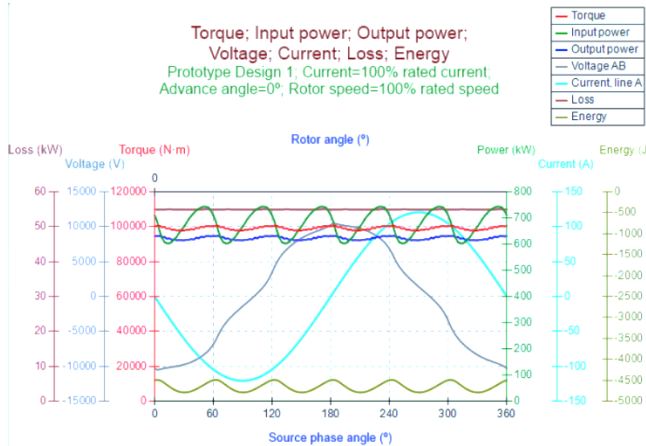

Figure 2. Power-angle curves

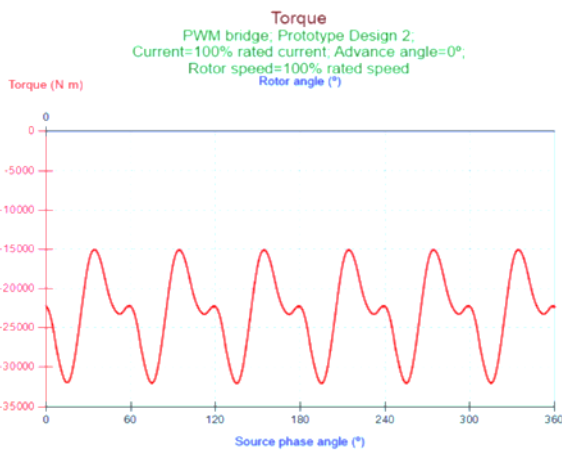

Figure 3. Electromagnetic torque versus rotor position angle relationship at tared stator current

Reactive power deforms power-angle curve because of significant non-saliency of PMSM. An additional deforming reactive torque appears as upper harmonics in harmonic spectrum of electromagnetic torque because of cogging torque and non-sinusoidal back-emf in stator windings with high mutual inductions [11-13].

2.2. Heat losses and cooling of PMSM

The high-power PMSM has higher heat losses, particularly in copper windings and lamination stacks. In Fig. 4, is represented the heat losses of developed PMSM in a rated operation without cooling. Since gearless drum-motor is appointed with fluid-tight housing aerodynamic cooling is lacking, air gap temperature could uncontrollably increase up to machine collapsed.

Given the type of closed PM-machines requires a forced cooling system with a cooling jacket and an effective liquid coolant. Assuming the articles [24-26], one of the most effective cooling methods is direct liquid-cooling using demineralized or deionized pH-controlled water flowing

along the parallel cooling circuits which ensure an operation temperature along the copper conductor surface by connected with stator stack in several points of extruding into copper windings stainless tubes filled with coolant [24-25].

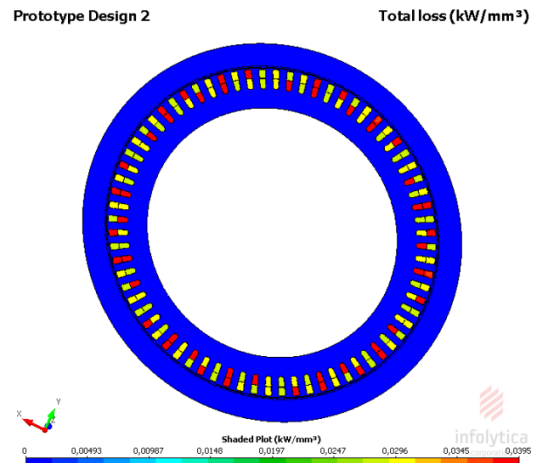

Figure 4. Total losses of modeling PMSM

Using direct-liquid cooling the temperature T_s to which the copper conductor can be cooled is determined by the convective heat transfer coefficient and heat exchange rate [26].

$$T_s = T_{dw} + \frac{P}{\pi \cdot D_{sst} \cdot l_c \cdot \alpha_{dw/c}} \quad (1)$$

where P is total losses of PMSM (see Fig. 2) and l_c is the length of the copper conductor equals to 2,849 m. The rough parameters of the possible cooling system of PMSM are shown in Table 2. Such values of tube diameter can decrease an efficiency of the machine, but expected influence does not significant and quantified as 0,1-0,2%.

Table 2. Rough parameters of cooling tubes and coolant

Parameter	Characteristics		
	Symbols	Unit	Value
The outlet temperature of the demineralized water	T_{dw}	°C	90
The inner diameter of the extruded steel tube	D_{sst}	m	0,05
Convective heat transfer coefficient between demineralized water	$\alpha_{dw/st}$	Wm ² /°C	0,045

In standard conditions the outlet temperature of water by inlet temperature equals to 40°C is within 80-90°C. On substituting of values in (1), rough temperature of cooled

conductors $T_s = 120,6$ °C which is sufficient and safety temperature for continuous operation with allowable heat losses.

3. Selection of control method for slow-moving PMSM

3.1. Sensorless methods vs sensor control methods

The crucial features of electric drive of belt conveyors are high static load resistant torque and unequal dynamic loads caused by dimensions and masses of conveyor components, curing of grease, splicing of the belt with fine fraction coal, etc. There are high requirements for reliability to electric drives, particularly smooth starting and smooth braking at loads. The performing of belt speed control depends on modes of operation of the conveyor system and the input flow of material [14].

The basic requirements that provide quality control of slow-moving PMSM of belt conveyor gearless drum-motor are next:

- (i) Wide torque control range for controllability at variable dynamic loads.
- (ii) High accuracy of regulation for control at low and close-to-zero rotations.
- (iii) Quick response time for stable control during frequent transient processes.

For control of a permanent magnet machine, it is necessary to know the actual value of rotor position angle θ . Sensorless control methods use an indirect estimation of angle θ , but the implementation of estimation methods is complicated by a large number of feedbacks on the control system, also calculating error can be significant, especially for operation at low speed [15]. In addition, sensorless control methods require very high computation capacity and significantly decrease response time. Sensor control methods use Hall sensors, resolvers and incremental encoders for measuring rotor position angle. The modern types of sensors measure angle θ with high accuracy and speed. Consequently, for control of slow-moving PMSM only sensor control methods was put under analysis.

3.1. Simulation of slow-moving permanent magnet synchronous machine system control

The model of the control system based on the mathematical representation of two-phase PMSM in dq -axes:

$$\begin{aligned}
 U_{sd} &= R_s i_{sd} - \frac{d\psi_d}{dt} = R_s i_{sd} + L_{sd} \frac{di_{sd}}{dt} - \omega_{0ei} L_{sq} i_{sq}, \\
 U_{sq} &= R_s i_{sq} - \frac{d\psi_q}{dt} = \\
 &= R_s i_{sq} + L_{sq} \frac{di_{sq}}{dt} + \omega_{0ei} L_{sd} i_{sd} + \omega_{0ei} \psi_{PM}, \quad (2) \\
 T_e &= \frac{3}{2} p_n [\psi_{PM} i_{sq} + (L_{sd} - L_{sq}) i_{sd} i_{sq}], \\
 \omega_{0ei} &= \frac{1}{J} (T_e - T_c).
 \end{aligned}$$

Scalar control based on proportional regulation of supply voltage amplitude and frequency is featured by simplicity and quick response time, but is not appropriate for slow-moving PMSM, because these methods use static models of steady-state conditions such as equivalent electric circuit and do not include dynamic processes cause in the electric drive during speed control and dynamic loads.

Applying of vector control methods assumes multi-phase systems transform into two-phase systems with dq -axes. One of the most effective control methods at low speed is field-oriented control (FOC) and direct torque control (DTC). In FOC electromagnetic torque and stator flux is indirectly controlled by control components of stator current vector, DTC method uses component of torque vector represented by stator current vector on quadrature axis and stator flux on direct current [16-18]. For the application of required impulses to semiconductor switch of inverter uses pulse width modulation (PWM) or space vector modulation (SVM). Comparative analyses of existing vector control systems for slow-moving PMSM, which is reproduced in the article [19], concludes that the most appropriate methods are FOC with PWM, DTC with SVM, differential and adaptive control [20-23]. However, the article [19] gives only theoretical analyses, in a computer simulation (by Matlab Simulink) FOC-PWM system shown the best result. The design of FOC-PWM vector control system with a position sensor (PS) and stator current component on direct axis $i_{sd} = 0$ presented in Fig. 5. There reference speed block produce required speed value, which depends on the rotor position angle θ and the conveyor load, rated speed of slow-moving PMSM $\omega = 6.28$ rad/s, resistance torque $T_c = 100$ Nm that is almost equal no-load operation. As current controllers were used standard proportional-integral (PI) controllers with saturations, and we used proportional-integrated-differential (PID) controller to control speed because it needs a quick time of response and high accuracy.

In Fig. 6, the simulation results are represented. as shown on plots, FOC-PWM control system performs smooth starting in 3 seconds time at no-load operation with good quality. Pulsations of electromagnetic torque not exceed 10% and produce by high cogging torque value in slow-moving power permanent magnet machine and PWM with high frequency of switching (20 kHz).

Although these simulation results are appropriate to the requirement of belt conveyor electric drive system control, ribbing of torque and speed will increase at working operation, by reason of unequal dynamic loads and mechanical hits. Consequently, the designed vector control system requires slow-moving PMSM conditions observer and additional speed and torque controllers.

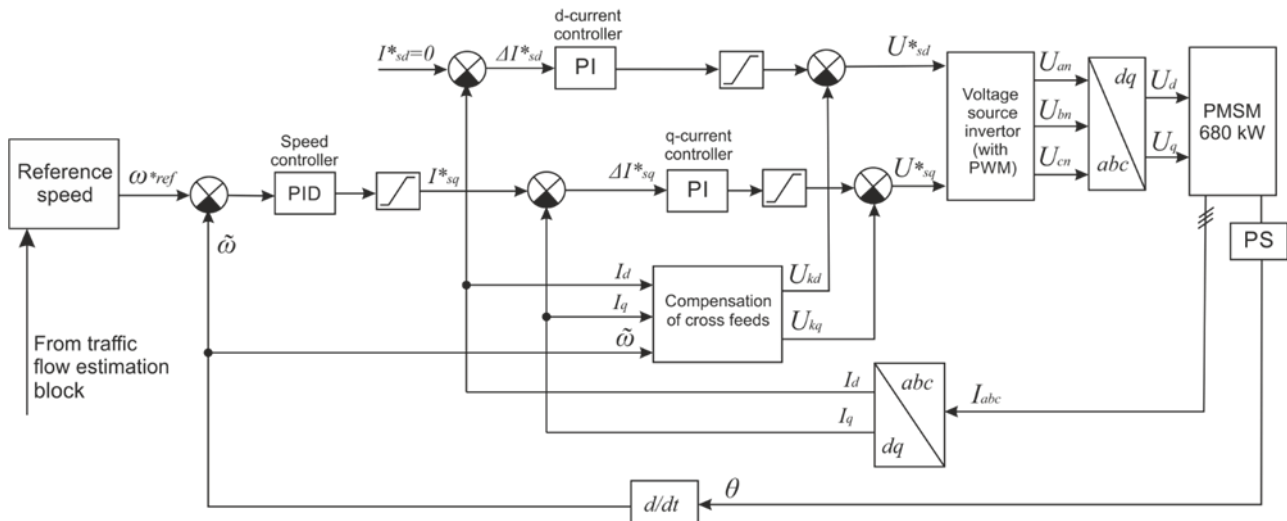

Figure 5. Design of FOC-PWM control system with $i_{sd}=0$ for slow-moving PMSM

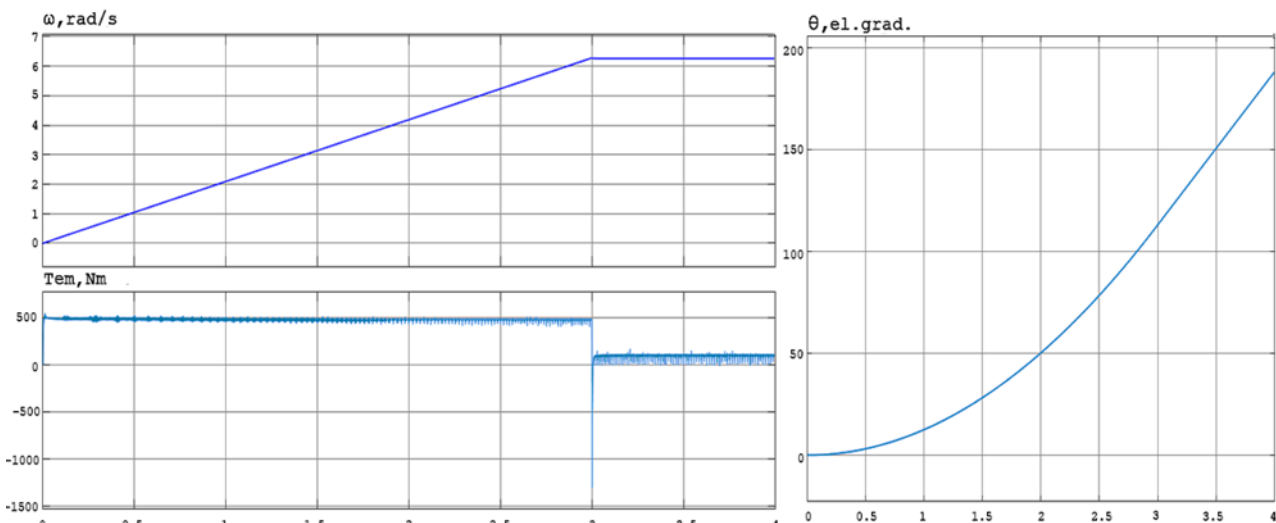

Figure 6. Angle speed, electromagnetic torque, and rotor position angle versus time relationships (smooth starting time $t = 3$ s, $T_c = 100$ Nm)

4. Conclusion

In this article was considered questions of high-power slow-moving permanent magnet synchronous machine control, associated with features of slow-moving PMSM construction and electromagnetic torque, also were presented simulation results for field-oriented control system with PWM and zero stator current on direct axis for PMSM of belt conveyor power electric drive at smooth starting without load. As shown in fig. 2.2., not significant pulsations of torque cause during smooth starting, which could hugely increase at load operation, and analyzed FOC-PWM control system requires slow-moving PMSM conditions observer and additional speed

and torque controllers for stable operation of belt conveyor during speed control and variable loads..

Acknowledgments.

The authors express their gratitude to colleagues from the Power Institute of T.F. Gorbachev Kuzbass State Technical University for organizing and holding the conference "Energy and energy saving: theory and practice" in Dec. 2017 because the speech prepared for this conference formed the basis of this article.

References

- [1] RATHMANN, B. (2015) *Mining conveyor systems. Solution portfolio*, HUB BU Process Industries Germany, Jornadas

- Técnicas*. (Cottbus: ABB – BU-Minerals, MTC Material Handling Germany).
- [2] KANARIS, A. (2016) *The Energy Savings & Performance Gains between two Conveyor Drive Designs*. (Van der Graaf Drum-motors).
- [3] NIEMANDT, W. and MINING, S. (2015) Overland conveying. Reaching New Lengths. *World Coal* **5**.
- [4] (2000) *Variable-speed drives for belt-conveyor systems* (Cottbus: ABB Process Industries – Open Pit Mining & Materials Handling).
- [5] Lauhoff, H. (2005) Speed Control on Belt Conveyors - Dose it Really save Energy. *Bulk Solids Handling* **25**(6): 368-377.
- [6] Gordon Cross, P.Eng (2015) Belt conveyors. Starting methods. *Magna Engineering* **3**.
- [7] Lu Zhongshu, Zhang Aijun, Ma Lie and Li Siyang (2009) Design of Line-Start Low Speed and High Torque PMSM for Gearless Drive System. In *Power Electronics and Motion Control Conference, IPEMC '09 IEEE 6th International*.
- [8] Zaritskaya E., Pryimak M., Oleynikov A. (2012) Evaluation of the influence of the configuration of the magnetic system on the characteristics of a slow-moving synchronous generator with permanent magnets. *EiE* **1**:28-32
- [9] Martínez D. (2012) Design of a Permanent-Magnet Synchronous Machine with NonOverlapping Concentrated Windings. In *XR-EE-E2C*.
- [10] Pyrhönen J. (2015) *Permanent magnet synchronous machine. Electrical drives*. (LUT, Department of Electrical Engineering).
- [11] Hooshang Mirahki, Mehdi Moallem. (2014) Torque Calculation in Interior Permanent Magnet Synchronous Machine Using Improved Lumped Parameter Models. *Progress In Electromagnetics Research* **39**:131–139.
- [12] Taichi Nakamura, Takafumi Koseki, Yasuaki Aoyama. (2011) *A low-speed high-torque permanent magnet synchronous motor. Reducing cogging torque and eddy current loss* (Tokyo: Koseki Laboratory).
- [13] Kubo, K., Watanabe, M., Kozawa, F., Kawasaki, K. (1990) Disturbance torque compensated speed observer for digital servo drives. In *16th Annual Conference of IEEE Industrial Electronics Society* **2**:1182–1187.
- [14] Belov M., Novikov A., Rassudov L. (2007) *Automated electric drive of standard production mechanisms and technological complexes* (Moscow: Academia).
- [15] Tarnetskaya A., Semykina I. (2017) The modern sensorless methods of rotor position estimation of permanent-magnet synchronous motors at low speed. *Bulletin of the Kuzbass State Technical University* **2**(120).
- [16] Vinogradov A.B. (2008) *Vector control of AC electric drives*, (Ivanovo: Ivanovo Power Engineering Institute).
- [17] Kalachev Y.N. (2013) *Vector control. Practical notes* (Company «EFO»).
- [18] Wang M.-S., Kung Y.-S., Nguyen Thi H., Chang C.-M. (2010) Superior low-speed control of a permanent magnet synchronous motor with digital encoder. In *Proceedings of the Institution of Mechanical Engineers, Part I: Journal of Systems and Control Engineering* **225**.
- [19] Tarnetskaya A., Semykina I. (2017) The control method selection for the slow-moving permanent magnet synchronous motor used in the belt conveyor electric drive for the underground mining. In *Integrated Innovative Development Of Zarafshan: Achievements, Problems, Prospects* (Tashkent: Muharrir nashtiyoyi).
- [20] Abd el Vkhab Amr Refki, Karakulov A.S. Dementiev Y.N. Kladijev S.N. (2011) Comparative analysis of vector control and direct torque control of synchronous electric motors with permanent magnets. *The Bulletin of the Tomsk Polytechnic University* **319**(4): 93-99.
- [21] Rahman M.F, Zhong L. (1999) Comparison of Torque Responses of the Interior Permanent Magnet Motor under PWM Current and Direct Torque Controls. In *IECON-99*.
- [22] Enrique I. Carrillo Arroyo. (2006) *Modeling and simulation of Permanent magnet synchronous motor drive system*. (Puerto Rico: University of Puerto Rico Mayagüez Campus).
- [23] Ming-Shyan Wang, Ying-Shieh Kung, Nguyen Thi Hanh, and Chia-Ming Chang (2011) Adaptive low-speed control of permanent magnet synchronous motors. *Electric Power Components and Systems* **39**(6): 563-575.
- [24] Arda Tüysüz, Francesca Meyer, Mathis Steichen, Christof Zwyssig and Johann W. Kolar (2017) Advanced cooling methods for high-speed electrical machines. *IEEE transactions on industry applications* **53**(3): 2077-2087.
- [25] Mariia Polikarpova (2014) Liquid cooling solutions for rotating permanent magnet synchronous machines. *Acta Universitatis Lappeenrantaensis* **597**: 117:147.
- [26] P. Ponomarev, M. Polikarpova and J. Pyrhönen (2015) Thermal Modeling of Directly-Oil-Cooled Permanent Magnet Synchronous Machine. *EFFIMA*.