

# An Investigation of Voltage Quality in Low Voltage Electric Power Distribution Network under Normal Operation Mode.

Patrick T. Ogunboyo\*, Remy Tiako\*\*, and Innocent E. Davidson\*\*\*

\*Discipline of Electrical, Electronic and Computer Engineering, UKZN, Durban, South Africa

\*\*Discipline of Electrical, Electronic and Computer Engineering, UKZN, Durban, South Africa

\*\*\*Department of Electrical Power Engineering, Durban University of Technology, Durban, South Africa

{ogunboyo@gmail.com, Tiako@ukzn.ac.za, Innocentd@dut.ac.za}

**Abstract.** With the ever increasing use of power semiconductor devices and information technology (ICT) equipment in the industries, homes and offices voltage quality are gaining meaningful attention to both industry and electric utility level. The lack of voltage quality causes unusually large economic losses all over the world, since voltage quality problem is one of the major power quality disturbances. This paper presents an investigative study on the 11/0.4 kV, low voltage electrical distribution network, aimed at analyzing voltage unbalance and variation problems and recommending an effective method of improving the voltage profile and reducing the voltage unbalance and variation to allowable standard. The network was modelled with the distribution network standard parameters for low voltage distribution network using MATLAB/Simulink Sim Power System tool box. The simulation results with distribution length 0.5 km for balanced three phase load is within the permissible voltage profile of  $\pm 5\%$ , reaching the customers, meaning it is admissible for customers use also it was established that an inadmissible poor voltage profile reaching the customers at the network end of distribution network lengths 0.8 km to 5 km which is less than the standard minimum permissible limit of  $-5\%$ , of nominal voltage value

**Keywords:** Low voltage, voltage variation, voltage unbalance, voltage profile, voltage quality, distribution network.

## 1 Introduction

This investigation is on voltage unbalance and variation problems in 11/0.4 kV low voltage electrical power distribution network using standard network parameters modelled in MATLAB/Simulink Sim Power System tool box. Customer's sensitive load, such as hospital equipment, semiconductor devices, information, communication equipment and factory automation equipment are highly susceptible to power supply disruptions, hence, the ultimate need for high power quality and voltage stability [1]. Voltage variation leads to equipment become too hot, intensified losses and overall decrease in performance of the electric power system components and customer devices. Poor voltage quality leads to huge economic losses

all over the world. It is estimated that power quality problems cost industries and commerce about £100 billion per annum in the European Union [2]

Voltage variation is considered to be the most undesirable power quality enigma in low voltage electrical power distribution networks [3]. Voltage variation can be observed in a specific person customer load due to phase load unbalances, particularly where large single-phase power loads are utilized [4]. Notwithstanding voltage on the transmission side are well regulated and balanced, the voltage at the end user level can become unbalanced due to load variations on each phase and different impedances [4]. Single-phasing, which is the complete loss of a phase, is an extreme case of voltage unbalance condition for a three phase circuit. Electric utilities usually attempt to share residential loads in the same way among all phases of electric power distribution networks [5]. An increase in voltage variation may lead to over-heating and reduce the rating of all induction motor kind of loads [6], [7]. Voltage variation can lead to network disturbances like malfunctioning of protection relays and voltage regulation device, and generation of non-characteristics harmonics from electronic loads [5].

Different kind of techniques for calculation definition and interpretation of voltage unbalance and variation as proposed in [8], [9], [10]. IEEE agreed standard practice for regulating electric power quality describes voltage unbalance also called voltage imbalance as the maximum deviation from the average of the three phase voltages or currents, divided by the average of the three voltages or currents, expressed in percent, also it can be defined as the ratio of negative or zero sequence component to the positive sequence component [11]. The ANSI standard recommends that the electric supply system should work and make to function to limit the greatest magnitude of voltage unbalance to 3% under no load condition [12]. Mathematically voltage unbalance can be illustrated, using formula given in (1):

$$V_{(\text{percent})} = \frac{\text{Maximum deviation from average voltage}}{\text{Average voltage}} * 100 \quad (1)$$

The voltage unbalance and variation factor or percentage voltage unbalance can be defined as the ratio of negative  $V_2$  and positive  $V_1$  sequence voltages [13], is the greatest employed and approved access of voltage unbalance in the system [14].

$$VUF = \frac{V_2}{V_1} * 100\% \quad (2)$$

As zero sequence power flow in the system is much more restricted and therefore has much smaller effect than negative sequence power flow, it is not contained in this definition of VUF.  $V_1$  and  $V_2$  are positive and negative sequence voltages, respectively, and can be obtained using symmetrical components.

Unbalance voltages produce undesirable effects on equipment and on the electrical power system, this is made possible due to the fact that a small unbalance in phase voltages can lead to large unbalance in the phase currents [15], [16]. In unbalanced situations, power systems will incur more losses and heating effects, and will experience instability compared to when the phases are balanced, the system is in a suitable position to react to unexpected and sudden load change [17].

In this study, an analysis of voltage variation was carried out for low voltage electrical power distribution network 11/0.4 kV, 500 kVA, urban and rural network. The results are presented under normal operating mode. The evaluation using MATLAB/Simulink modelling method is

used to investigate and to predict the network voltage variation and unbalance for the different network lengths for balance three phase load.

## 2 System Model

### 2.1 Model of LV Electrical Distribution Network

Voltage unbalance and variation in low voltage (LV) distribution network was modelled and simulated in MATLAB/Simulink using Sim Power System tool box. The LV electric power distribution system presented in this model is based on the standard system principles trailed by electricity supply industries, tabulated in Table I. Figure 1 illustrates the proposed Simulink model. The length of the LV electric power distribution lines ranges from 0.5 km to 5 km, the voltage levels and conductor type of the LV access system make up of 400 V<sub>L-L</sub>, 230 V<sub>L-N</sub> through 11/0.4 kV, distribution transformer, based on all-aluminium conductor (AAC) standard. In the proposed Simulink model, a three phase load balanced at 80% transformer rating is considered. The total load injected to the three phase is 360 kW at 0.9 pf, 80% full load capacity. Therefore, the loads on phase A, B, and C for balance load are 120 kW for each phase respectively.

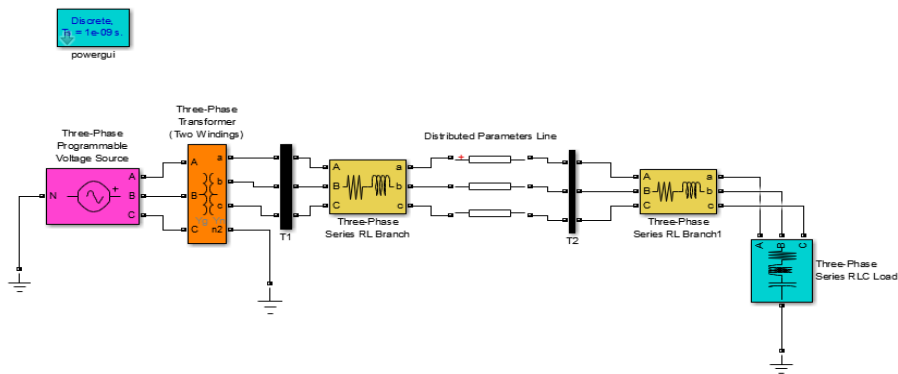

**Fig. 1.** Simulation model of 11/0.4Kv LV electrical distribution network

### 2.2 Network Structure

A low voltage (400V) radial network residential urban/rural electrical distribution network was considered for low voltage variation and unbalance investigation. In this model, the transformer is delta/star connected, the phase loads are assumed to be balanced; neutral conductor is utilized for the transfer of unbalance current circulation and the analysis employed is on mutual effect of the three phases. The IEEE approved practice for low voltage distribution power factor close to unity was used. The network supplies electricity to offices, housing and factories. The feeder has three phase and four wire system with even balance in length. The poles are positioned at a

distance of 50 meters from one another. At each pole, factories, offices are served from each phase. The technical data of the distribution network are provided in Table 1

**Table 1.** Parameters of LV distribution network

S/N	Material	Parameter
1	Distribution Transformer	11/0.4 kV, 500 kVA, Δ/Y grounded.
2	MV Feeder	Three Phase 11 kV radial, overhead line.
3	LV Feeder	3-phase 4-wire, 400 V, overhead all-aluminium conductor 100 mm <sup>2</sup>
4.	Balance Load	Phase A, B and C Load are 120 kW each at 0.9 pf transformer loading is 80% of transformer rating.

## 2.3 Determination of Electrical Distribution Network Parameters and Load

To determine the voltage profile and current profile at each load point on the distribution network, a simulation was carried out on the modelled electrical distribution network using MATLAB/Simulink Sim Power System tool box. This was done in order to estimate the voltage drop on each phase of the network, hence the voltage profile, percentage voltage deviation and voltage losses on the network was evaluated.

### 2.4 Network Parameters

The line parameters resistance  $R$ , inductance  $H$ , and the capacitance  $C$ , were determined by computation.

The resistance,  $R$  of the line is determined by using equation (3):

$$R = \frac{\ell L}{A} \quad (3)$$

where  $\ell$  is the resistivity of all-aluminum conductor and is given as  $2.85\mu\Omega\text{-cm}$ ,  $L$  is the length of each segment of the line, and  $A$  is the cross sectional area of the all- aluminum conductor used.

The inductance of each phase and capacitance can be calculated using equation (4) and (5)

$$L = 2 \times 10^{-7} \ln \left( \frac{GmD}{GmR} \right) H / m \quad (4)$$

$$C = \frac{2\pi\epsilon}{\ln \left( \frac{GMD}{r} \right)} F / m \quad (5)$$

Where  $\epsilon_0$  is  $8.85 \times 10^{-12}$ . The values of geometric mean distance (GMD) and geometric mean radius (GMR) are calculated using equations (6) and (7) respectively.

$$GMD = \sqrt[3]{D_{ry} \times D_{yb} \times D_{br}} \quad (6)$$

$$GMR = re^{-0.25} \quad (7)$$

where  $r$  is the radius of the all-aluminium conductor and  $D_{ry} = 0.279$  m,  $D_{yb} = 0.279$  m, and  $D_{br} = 0.559$  m are distance between conductors of two phases for overhead LV electrical distribution network. For 100mm<sup>2</sup> size all-aluminium conductor, it has 7/4.39mm strands of conductors.

## 2.5 Determination of Voltage Deviation ( $U_{dev}$ , %) of the Network by calculation

In a bid to determine the voltage deviation of the 11/0.4 kV distribution network. A three phase V-I measurement instrument in the Simulink model was used for voltage measurements between phase and neutral on the network. Readings obtained are presented in Tables 2 and 3 respectively.

The voltage deviation, ( $U_{dev}$ , %) was determined using equation (8):

$$U_{dev}, \% = \frac{U_{ph} - U_{nom}}{U_{nom}} * 100, \% \quad (8)$$

where  $U_{ph}$  is the measured phase voltage,  $U_{nom}$  is the normal voltage.

## 3. Simulation Results and Discussions

### 3.1 Results of Simulation of Three-Phase Balance Load

The results of simulation of the voltage variation and unbalance investigation of network parameters are presented in Figures 2 to 12, Figure.13 shows the curve of voltage profile for the balance three phase load and Table 2 shows the summary of the voltage profile readings of the electrical distribution network. Analysis of the results shows that only at 0.5 km length of the network is the voltage drop falls within standard allowable voltage range of  $\pm 5\%$  of the nominal voltage value with per unit voltage value of 0.95 p.u at the feeder end. The remaining network lengths of 0.8 km to 5 km the voltage drops is not within minimum permissible limit of -5% of nominal voltage value. From the curve of voltage profile it is obvious that the voltage profile decreases sharply with increases in distribution network lengths, at 2.5 km the voltage profile is 0.50 p.u meaning that voltage reaching the consumers end is half the nominal voltage, at 5 km length the voltage profile is 0.20 p.u this is a worst scenario. Therefore, the voltage drops in the network at 0.8 km to 5 km length are significant since it does not fall within -5% and +5% allowable voltage drop. Hence is not admissible.

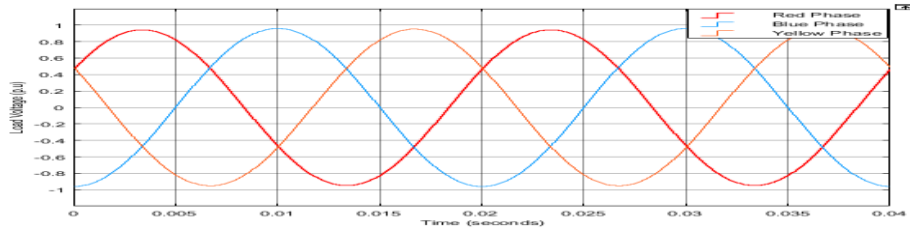

**Fig. 2.** p.u voltage profile at 0.5 km for 3-phase balance load

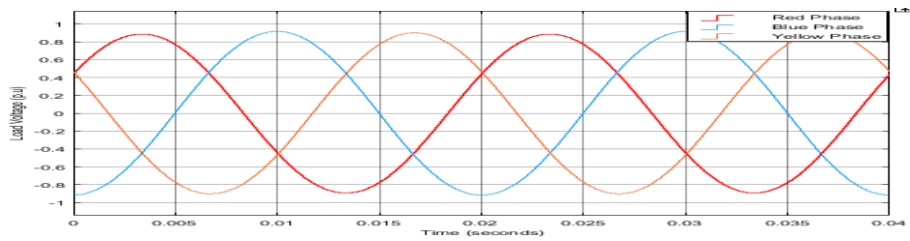

**Fig. 3.** p.u voltage profile at 0.8 km for 3-phase balance load

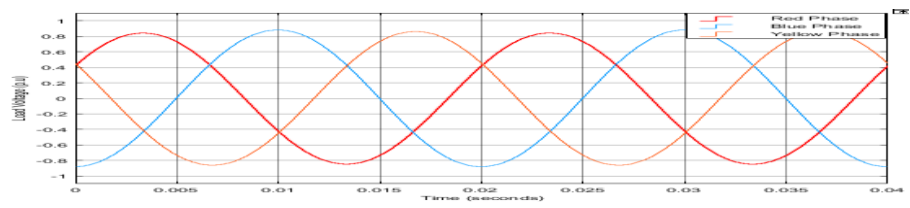

**Fig. 4.** p.u voltage profile at 1 km for 3-phase balance load

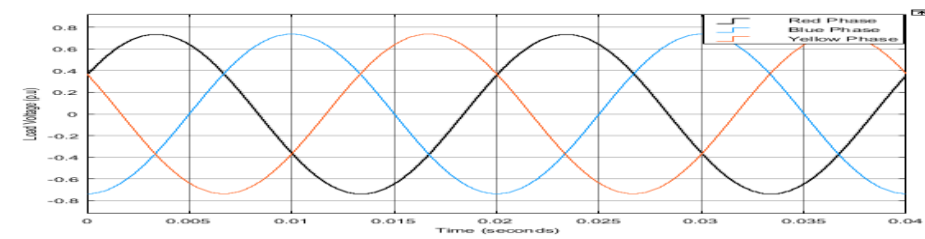

**Fig. 5.** p.u voltage profile at 1.5 km for 3-phase balance load

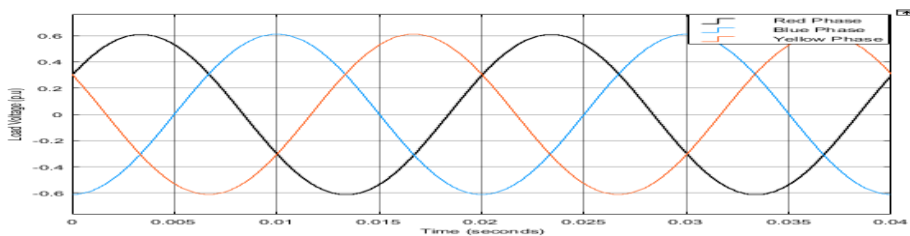

**Fig. 6.** p.u voltage profile at 2 km for 3-phase balance load

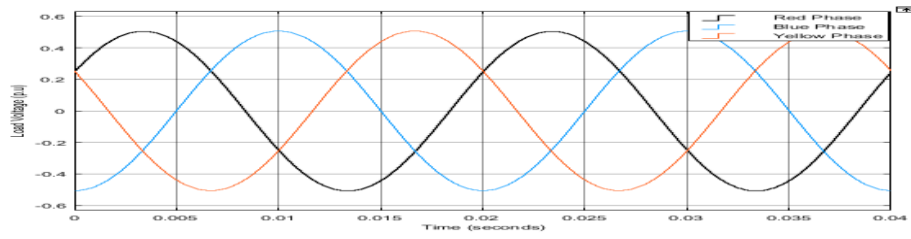

**Fig. 7.** p.u voltage profile at 2.5 km for 3-phase balance load

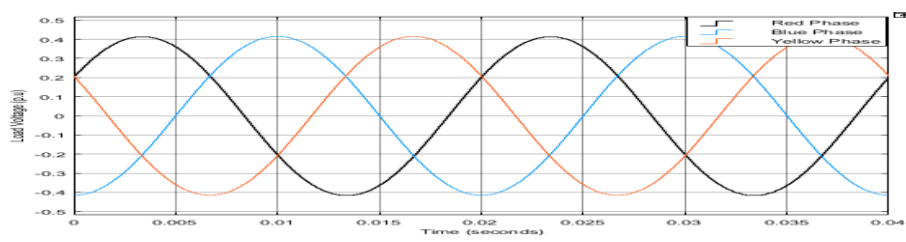

**Fig. 8.** p.u voltage profile at 3 km for 3-phase balance load.

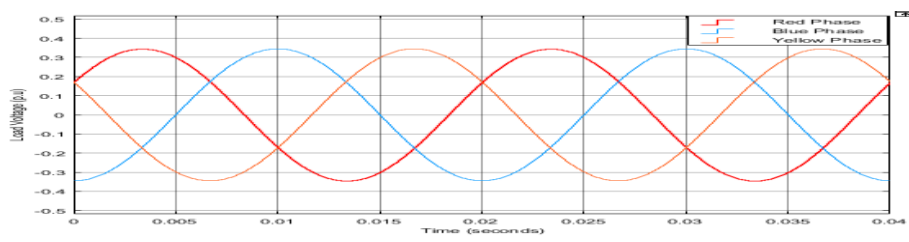

**Fig. 9.** p.u voltage profile at 3.5 km for 3-phase balance load

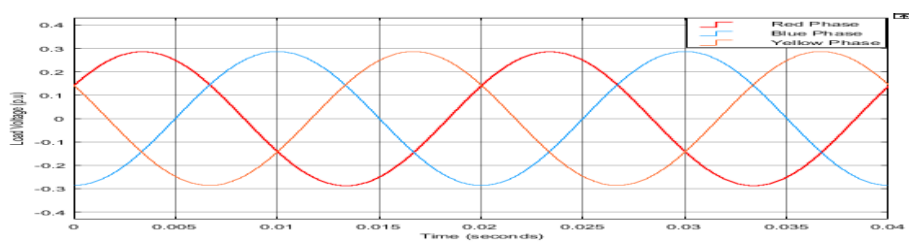

**Fig. 10.** p.u voltage profile at 4 km for 3-phase balance load

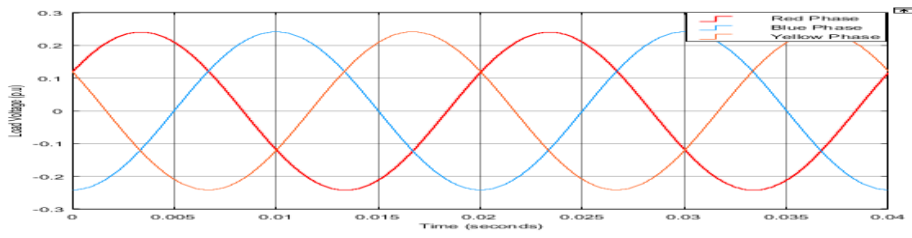

**Fig. 11.** p.u voltage profile at 4.5 km for 3-phase balance load

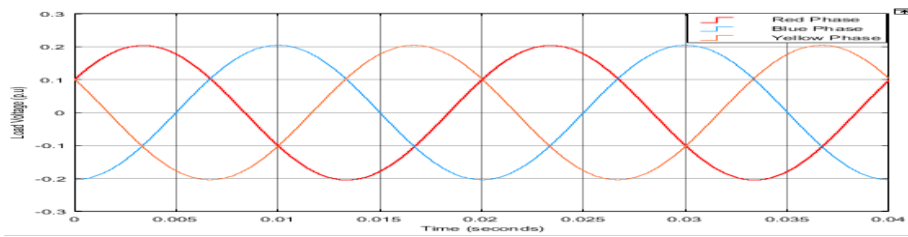

**Fig. 12.** p.u voltage profile at 5 km for 3-phase balance load.

**Table 2.** Per-unit measurement of voltage profile for three phase balanced load

Network length (km)	Voltage profile (p.u)
0.5	0.95
0.8	0.90
1.0	0.85
1.5	0.73
2.0	0.61
2.5	0.50
3.0	0.41
3.5	0.34
4.0	0.28
4.5	0.23
5.0	0.20

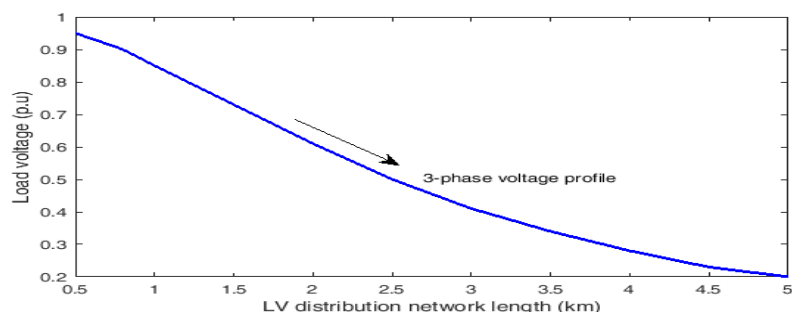

**Fig. 13.** Curve of p.u voltage profile of three-phase balance load

### 3.2 Voltage Deviation for Three-Phase Balance Load

The purpose of measuring voltages at the load points is to determine the profile of voltages across the network as well as assess the loading condition. Table 3 shows computation of voltage deviation for three phase balance load and Figure 14 shows the pie chart of percentage voltage deviation of network for voltage deviation analysis for three phase balance load. It shows that  $U_{dev, \%}$  of 0.5 km network falls within the normal minimum permissible range of -5%, while the remaining lengths of 0.8 km to 5 km does not fall within the normal permissible range, implying a poor voltage quality reaching end users: all values of  $U_{dev, \%}$  are less than the standard minimum -5% for 0.8 km to 5 km distribution feeder lengths. Figures 15 and 16 show the bar charts of percentage voltage deviation and bar chart of voltage drop along the feeder length of low voltage distribution network.

**Table 3.** Computation of voltage deviation for three phase balance load

S/NN	L, (km)	$\Delta U_{dev}, V$	$\Delta U_{dev}, \%$	$\Delta U, V$	$\Delta U_{std.min \text{ and } max \%}$
1	0.5	0.05	5	11	$\pm 5\%$
2	0.8	0.1	10	22	$\pm 5\%$
3	1.0	0.2	20	44	$\pm 5\%$
4	1.5	0.27	27	59	$\pm 5\%$
5	2.0	0.37	37	81	$\pm 5\%$
6	2.5	0.5	50	110	$\pm 5\%$
7	3.0	0.59	59	130	$\pm 5\%$
8	3.5	0.66	66	145	$\pm 5\%$
9	4.0	0.72	72	158	$\pm 5\%$
10	4.5	0.77	77	169	$\pm 5\%$
11	5.0	0.8	80	176	$\pm 5\%$

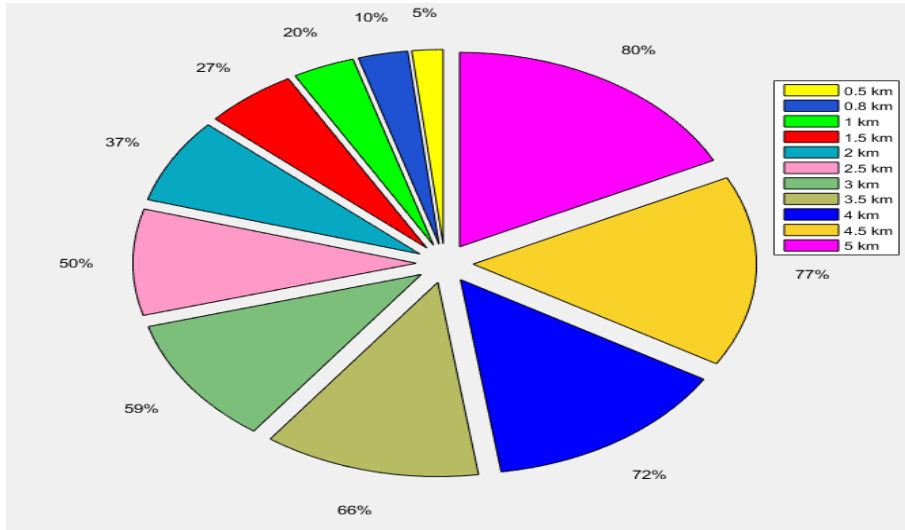

**Fig. 14.** Pie chart of percentage voltage deviation for three-phase balance load

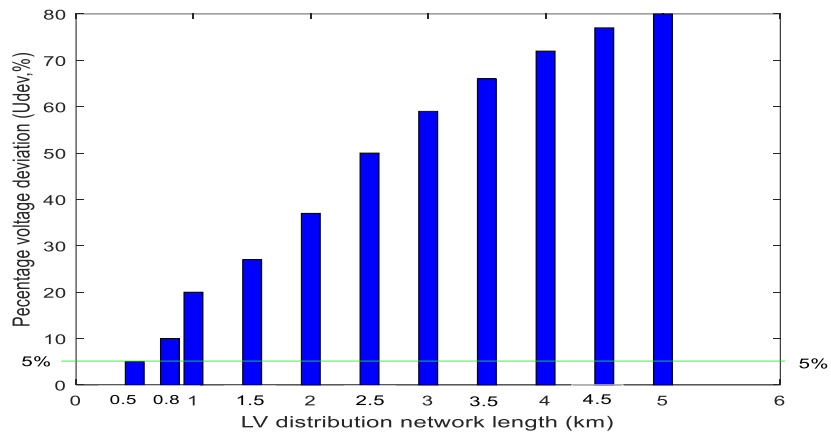

**Fig. 14.** Bar chart of percentage voltage deviation for three-phase balance load showing the distribution length of voltage allowable

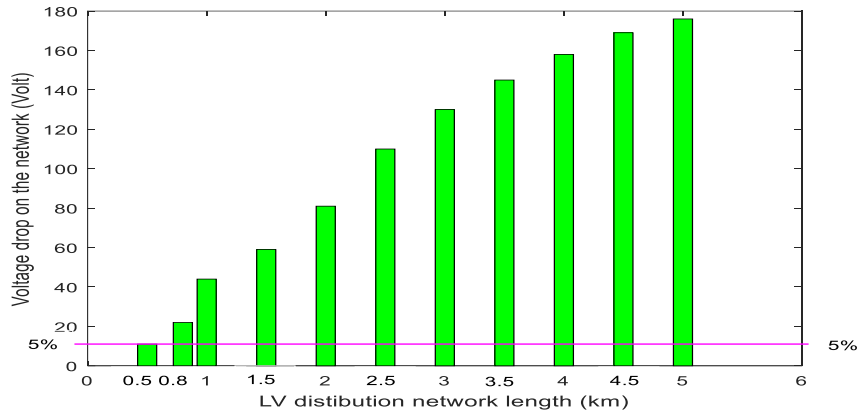

Fig. 15. Bar chart of voltage drop on three-phase balance load

#### 4. Conclusions

Based on the simulation result analysis of LV electric power distribution network standard parameters using MATLAB/Simulink Sim Power System tool box. It is shown that the voltage variation and unbalance for 0.5 km distribution network length for balance three phase load is admissible for customers from the beginning to the end of the feeder as designed with engineering standard and judgements. However, it is also established that the voltage variation and unbalance for distribution network lengths of 0.8 km to 5 km for balance three phase load from the beginning to the end of the feeder are less than minimum standard permissible limit of -5%, or 0.95 p.u of the nominal voltage value, hence voltage is inadmissible for customers use. Furthermore, it is shown that a permissible voltage range can be attained if the electricity distribution companies will follow the minimum standard for distribution network length at 80% full load transformer rating with voltage booster connected along the network length. Finally, it was established that voltage variation in low voltage distribution network will amplify or fall based on the network length and the load on the phases. The proposed solutions to poor quality voltage in low voltage electric power distribution systems are: [1] the electricity distribution companies must follow the minimum standard for distribution network feeder length and maximum transformer loading of 80% transformer rating with voltage booster connected to the feeder bus of 11/0.4 kV to boost the supply voltage to standard +5% nominal voltage value. This will remove the problem of critical voltage drops in low voltage electric power distribution networks length. [2] In the case of extending the distribution length beyond the minimum standard distribution length, electricity distribution companies must provide an efficient and effective means of voltage booster connected along the feeder length in order to improve the voltage profile from the beginning of the network to the end to the standard permissible range. If fully implemented, the quality of electricity supply will improve and thereby reduce load shedding during winter and peak load. It will also decrease incidents of malfunctioning of

customers single and three phase sensitive loads. By extension, this will raise the general living standard of the customers deriving from the 11/0.4 kV electric power distribution network.

## 5. Acknowledgments

This work has been supported by Eskom Power Plant Engineering Institute (EPPEI), and The University of KwaZulu-Natal, Durban, South Africa.

## 6. References

- 1 Goswami, A. et al.: Minimization of voltage sag induced financial losses in distribution systems using FACTS devices. *Electric Power Systems Research*. 81(3): 767-774 (2011).
- 2 De Keulenaer, H.: *The hidden cost of poor power quality*. European copper institute (2003).
- 3 Ghosh, A. Ledwich, G.: *Power quality enhancement using custom power devices*, Kluwer Academic Publishers, ISBN: 1402071809 (2004).
- 4 Short, T.A.: *Electric Power Distribution Handbook*, CRC Press, (2004).
- 5 Jouanne, AV., Banerjee, B.: Assessment of voltage unbalance," *IEEE Trans. On Power Delivery*, Vol. 16, No. 4, pp. 782-790 (2007).
- 6 Gnacinski, P.: windings temperature and loss of life of an induction machine under voltage unbalance combined with over-or under voltages," *IEEE Trans. On Energy Conversion*, Vol. 23, No. 2, pp. 363-371 (2008).
- 7 Pillary, P., Manyage, M.: Loss of life in induction machines operating with unbalanced supplies," *IEEE Trans. On Energy Conversion*, Vol. 21, No. 4, pp. 813-822 (2006)
- 8 IEEE Recommended Practice for Monitoring Electric Power Quality," *IEEE Std 1159-1995*, p.i (1995).
- 9 Singh, AK. et al.: Some Observation on Definitions of Voltage Unbalance," in *Power Symposium. NAPS 07. 39<sup>th</sup> North American*, pp. 473-479 (2007).
- 10 Garcia, DC. et al. : Voltage unbalance numerical evaluation and minimization," *Electric Power Systems Research*, vol. 79, pp. 1441-1445 (2009).
- 11 Kini, PG., et al.: A Novel Approach toward Interpretation and Application of Voltage Unbalance Factor," *Industrial Electronics, IEEE Transactions on*, vol. 54, pp. 2315-2322 (2007).
- 12 Gul, O.: An Assessment of PQ and Electricity. *Electrical PQ and Utilisation Journal*, (2008).
- 13 Hansen, CW.: Power system state estimation using three phase model,". *IEEE Transactions on Power Systems*, vol. 10, No. 2 pp. 818-824 (1995).
- 14 EN 50160.: *Voltage Characteristics in Public Distribution Systems*. European Committee for Electro technical Standardization (CENELEC) (1994).
- 15 Muljadi, E., Schiferl, R., Lipo, T.A.: Induction machine phase balancing by unsymmetrical thyristor voltage control," *IEEE Trans. Industry Applications*, vol. IA-21, no. 4, pp. 669-678 (1985)
- 16 Lee, C. Y.: Effects of unbalanced voltage on the operation performance of a three-phase induction motor," *IEEE Trans. Energy Conversion*, vol.14, no. 2, pp. 202-208 (1999).