

New numerical sizing approach of a standalone photovoltaic power at Ngoundiane, Senegal

A. Sadio¹, I. Fall² and S. Mbodji^{1,2}

¹Laboratory of Semiconductors and Solar Energy, Department of Physics, Faculty of Science and Technology, Cheikh Anta Diop University, Dakar, Senegal;

²Research team in renewable energies, materials and laser of Department of Physics, Alioune Diop University of Bambey, Bambey, Senegal.

E-mail: senghane.mbodji@uadb.edu.sn; ibrahima.fall@uadb.edu.sn; amysadio12@gmail.com.

Abstract

A new sizing method based on a numerical approach using the average meteorological data and the load demand of the Ngoundiane site along with both concepts of ALPSP and TLCC is treated in this study. The intuitive method, has been first applied to delimit the PV capacity range. Thereafter, the incoming new approach that we propose, consists in elaborating a simple algorithm based on a numerical determinist sizing approach by adapting the available average data to the mathematical equations used in numerical approach. The results show that for a same value of the total capacity of PV array, estimated to 177.5 kW_p, the proposed numerical sizing method decreases the storage system capacity to 75% and the TLCC to 65% compared to the intuitive method.

Keywords: Standalone PV System, Intuitive Method, Numerical Method, Determinist Approach.

Received on 28 October 2017, accepted on 28 December 2017, published on 30 January 2018

Copyright © 2018 A. Sadio *et al.*, licensed to EAI. This is an open access article distributed under the terms of the Creative Commons Attribution licence (<http://creativecommons.org/licenses/by/3.0/>), which permits unlimited use, distribution and reproduction in any medium so long as the original work is properly cited.

doi: 10.4108/_____

1. Introduction

The design of a photovoltaic power plant goes with the determination of the different components size that form the system whose results are important in the optimal conception of these kind of systems and depend strongly on the meteorological variables that fluctuate and on the load profile which is generally not constant.

In the literature, different methods of sizing have been developed, they differ in terms of simplicity and reliability [1] and can be categorized as intuitive, numerical, analytical [2], Artificial Intelligence (AI) [2] and hybrid [2].

The intuitive methods use simplified computations to find the components sizes of the system. Generally, the month with the worst meteorological conditions (the month having the smaller irradiation), the monthly or the annual average

irradiation, and the daily load demand are considered in the sizing process. Intuitive methods present some drawbacks because they don't neither establish quantitative relationship between the different subsystems in a standalone photovoltaic (PV) system, nor consider the fluctuation in solar irradiation. Furthermore, they may lead to under or over sizing of the standalone PV system that will cause low reliability for the system or (and) increase system's capital, operational and maintenance costs.

The numerical sizing methods consist on making simulations at each time interval, usually an hourly or daily time to determine at each period, the energy balance of the system and the batteries state of charge. One distinguishes the deterministic approach, which does not consider the uncertainty associated with solar radiation due to the difficulties in finding data set for a specific locality, and the probabilistic approach, which considers the effect of solar radiation variability in the system design [2]. These methods

* Corresponding author, Email: senghane.mbodji@uadb.edu.sn

offer more accurate results and allow the evaluation of the system reliability. Indeed, the reliability is the ability of a photovoltaic system to meet load requirements for long period of time. It can be quantified by the Loss of Lower Supply Probability (LPSP) which represents the mean load percentage that is not supplied by the photovoltaic system for large periods of time [3]. The LPSP is also known as the Loss of Load Probability (LOLP), the Loss of Power Probability (LOPP), and the Load Coverage Rate (LCR) [4]. It represents the load dissatisfaction rate.

In the analytical methods, as shown in [5], the sizes of system are expressed by mathematical equations like a function of the system reliability. The best configuration of a standalone PV system is evaluated by comparing single or multiple performance indexes of different schemes. The advantage of the analytical methods is that they enable a simple calculation of the different components of system. Its drawback is that equations depend on the localities and results may be imprecise. These methods are simple to apply but they are not general [5].

Artificial Intelligence (AI) methods are used to overcome the unavailability of the meteorological data for sizing standalone PV systems in remote areas [2]. As reported by Tamer Khatib et al. [2], AI technologies have a natural synergism that can be exploited to produce powerful computing systems. AI methods regroup the Artificial Neural Network (ANN), the Genetic Algorithm (GA), the Fuzzy Logic (FL) and the Tabu Search (TS) [2].

These sizing methods have been used by different researchers for the optimal sizing of photovoltaic system:

M. S. de Cardonna et al. [3] used some meteorological data for several Spanish sites and developed a simple numerical model for the sizing of standalone photovoltaic system. They utilized a model of linear regression to identify the variables which enable to find the system optimal sizes with the smaller error. For different values of the LOLP, an iteration proceeding was applied up to have a LOLP which can size the system with a 2% error.

L. Hontoria et al. [6] proposed a new analytical approach for the sizing of standalone photovoltaic system based on technic of improved neural network called "Multilayer Perceptron" (MLP). With the use of four parameters like the capacity of PV generator (CA), the capacity of storage battery (SC), the LOLP, and the annual clearness index (K), the MLP method generated accurate LOLP curves (variation of CA versus variation of SC for a given LOLP).

W. X. Shen et al. [7] studied the optimal sizing of solar array and storage battery in a standalone photovoltaic system in Malaysia. The authors set the inclination and computed the LPSP for different combinations of PV array and storage batteries. The optimum configuration of system has been obtained by minimizing the cost of the system, at a desired reliability level.

A. Q. Jakhrani et al. [8] have established a novel analytical model for optimal sizing of standalone photovoltaic system. Their model considers two major elements namely the system cost and the energy reliability, which are functions of PV array and batteries capacities. For different values of LPP (Lost of power probability), PV array area versus

useful battery storage capacity has been drawn. The optimal configuration has been obtained by minimizing the system cost.

H. A. Kazema et al. [9] have treated the sizing of a standalone photovoltaic/battery system at minimum cost for remote housing electrification in Sohar, Oman. Their objective was to choose the best tilt, and the PV module and battery optimal capacities. Considering four scenarios of optimum tilt angle variation namely, monthly optimum tilt angle variation, seasonally tilt angle variation-assumption A (four seasons a year), seasonally tilt angle variation-assumption B (two seasons a year) and annual tilt angle variation, the best strategy which gives the optimal tilt angle corresponds to the third scenarios. Concerning the PV modules and storage batteries capacities, a numerical sizing method has been proposed and has been compared to an intuitive sizing method.

A. Bouabdallah et al. [10] proposed a safe sizing methodology applied to a standalone photovoltaic system. This method considers the solar irradiation variability by a modelling of index clearness across Markov transition matrix. This model has been applied by using hourly data at Saint-Martin, France. It was found that LPSP is sensitive to the diversity of possible sunniness configurations.

N. D. Nordin et al. [11] have studied a new numerical sizing method, based on the Ampere-Hour approach, for the conception of standalone PV systems.

In this paper, we propose a new sizing method based on the numerical sizing approach for a standalone photovoltaic power system at Ngoundiane site, in Senegal. The principal objective of this study is to develop a numerical sizing method adapted to the nature of solar irradiation and temperature and the load demand of the Ngoundiane site. First, we apply an intuitive method and thereafter the numerical sizing method is implemented. Results of the proposed methods are compared with the results of the other methods.

2. Input parameters

The annual profile of daily solar irradiation monthly average (I_G) of the zone of Ngoundiane is shown in figure 1. It corresponds to the annual variation of monthly average irradiation of the Ngoundiane zone. These data have been provided by national agency of civil aviation and meteorology (ANACIM), Senegal. In figure 1, we noted that the higher solar irradiation is obtained at month of April with a value of 7.05 kWh/m²/day, while the smaller irradiation is recorded at month of December with a value of 4.88 kWh/m²/day which will be used in the sizing process. The average value of irradiation is 5.87 kWh/m²/day.

The annual variation of the energy consumption of the Ngoundiane site is represented in figure 2. The daily peak load demand occurs during winter. We take this value in the sizing process which is of about 554 kWh/day and suppose that it is identical for all days of year. During night, the energy consumption falls up to reach a value of 120.301 kWh.

In figure 3, we have the variation of the monthly average temperature of the Ngoundiane zone of year 2015. Months of January and February record the smaller average temperature with a value of 23.5 °C. Maximal average temperature value is 29.15 °C and is obtained at month of November. This value will be used in simulations. All these parameters are kept constant during the sizing proceedings. The other input parameters are the technical and economical specifications of the different PV system components. These specifications are shown in table 1.

3. Description of sizing process

The synoptic of the standalone photovoltaic system considered in this paper is shown in figure 4. This figure consists of a PV module, battery park, charge controller and MPPT command, and inverter.

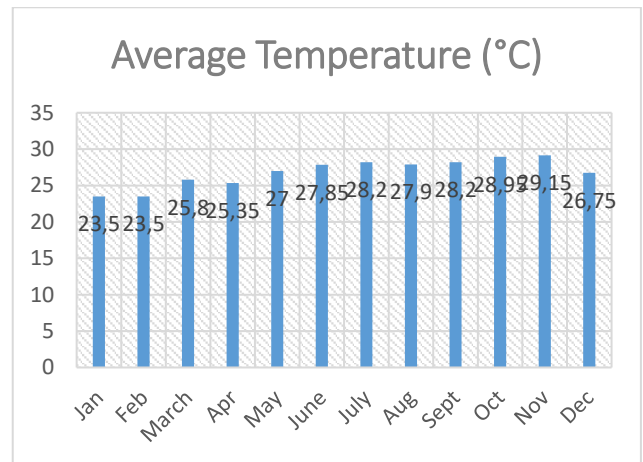

Figure 3. Annual variation of monthly average temperature of year 2015 of Ngoundiane Site

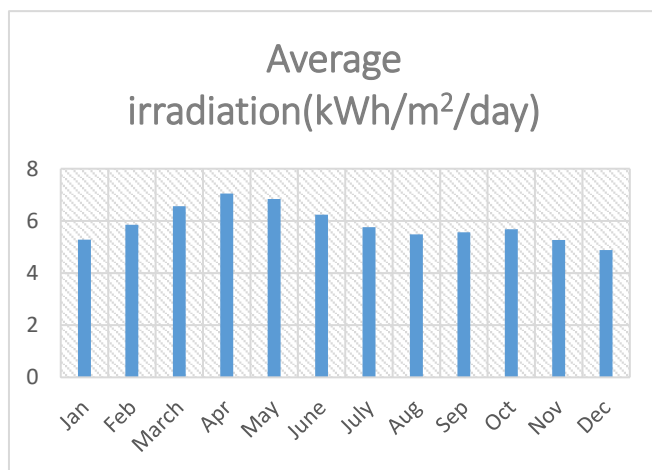

Figure 1. Annual variation of monthly average irradiation of Ngoundiane Site

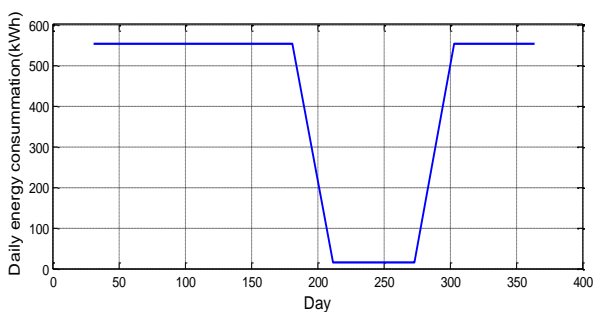

Figure 2. Annual variation of maximal daily energy consumption of Ngoundiane Site

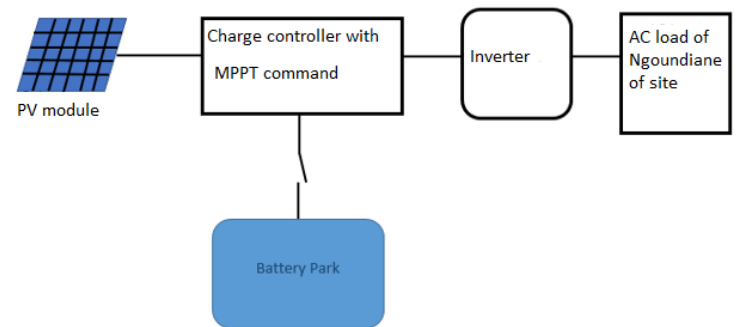

Figure 4. Synoptic of studied solar photovoltaic system

- PV modules are the main energy sources in the standalone PV system, they transform the sunshine into continuous current.
- Batteries are crucial components in the standalone photovoltaic system. They act as a dumper by allowing the storage of excess from the PV modules and provide energy for the load during night or non-sunny days. They can be considered as a stabilizer since they feed the load with constant voltage. Most of the batteries used in PV systems nowadays are lead acid batteries [11].
- MPPT charge controller is a charge controller integrating the function of maximal power point research providing the available maximal battery charge current. It manages energy flows into the battery so that the battery will be provided with optimum charges [12]. It protects the batteries against overcharges, and complete discharges, allowing to struggle against their premature ageing.
- Inverter converts the continuous power generated by the PV modules into alternative power.

3.1. Procedure of intuitive sizing method

We use equations (1) and (2) to find the total power of PV modules required to satisfy the load demand of Ngoundiane site and the requisite capacity of storage for supplying the electricity demand for two days without solar contribution, respectively.

$$P_{PV} = \frac{E_L}{\eta_S \eta_{inv} PSH} S_f \cdot (1)$$

Where E_L is the daily load energy consumption, η_S and η_{inv} are the efficiencies of the system's components, PSH is the peak sunshine hours and S_f is the safety factor which represents the compensation of resistive losses and PV cell temperature losses [9].

$$C_{bat} \frac{E_L D}{V_{bat} \eta_{bat} DOD} \cdot (2)$$

D is the number of autonomous days, V_{bat} is the voltage of the battery, η_{bat} is the efficiency of the storage battery, and DOD is the battery depth of discharge rate.

The energy capacity of the battery in Wh is the energy quantity that battery can provide during a given time. It is calculated from equation (3):

$$C_{Wh} = DOD \cdot V_{bat} C_{bat} \cdot (3)$$

To compensate the energy losses, due to different conversions and the nonlinear characters of the components, the system is oversized by considering the various components efficiencies and safety factor [13]. Thus equation 1 can be rewritten as follows:

$$P_{PV} = \frac{E_L}{0.65 I_G} \cdot (4)$$

I_G is the monthly average of daily solar irradiation in kWh/m²/day, and 0.65 takes into account all the losses of system, namely the different efficiencies of components, resistive losses and PV cell temperature losses.

3.2. Procedure of numerical sizing proposed

Since input parameters of Ngoundiane site are averaged data, we are going to elaborate from these data, a simple algorithm based on the determinist approach to improve results obtained. The used different hourly equations in numerical methods which describe the PV system behavior, are adapted to the data nature of Ngoundiane site. So, the different energy models are expressed in terms of mean.

3.2.1. Energy modelling of PV array

The daily average output generated by the PV array, E_{PVav} is calculated from the following equation:

$$E_{PVav} = A_{PV} \cdot I_G \cdot \eta_{inv} \cdot \eta_{wire} \cdot \eta_r \left[1 - \beta \left(T_{amb} + \frac{G}{800} (T_{NOCT} - 20) \right) - T_{ref} \right] \cdot (5)$$

Where A_{PV} is the area of PV array, η_r is the nominal efficiency given by the manufacturer, η_{inv} and η_{wire} are the efficiencies of inverter and wire, respectively, β is the temperature coefficient, T_{amb} is the ambient temperature, G is the solar irradiance in W/m², T_{NOCT} is the nominal cell temperature, and T_{ref} is the reference temperature.

The area PV array is related to the PV capacity by following equation:

$$A_{PV} = A_{PV,U} \frac{P_{PV}}{P_{PV,U}} \cdot (6)$$

$A_{PV,U}$ is the unitary area of PV array and $P_{PV,U}$ is the unitary capacity of a PV module.

The difference between the average output of PV array and the daily load energy consumption is computed by following equation:

$$\Delta E = E_{PVav} - \frac{E_L}{\eta_{inv}} \cdot (7)$$

If ΔE is lower than zero, the average energy stored in the storage system in kWh E_{batav} is calculated as following:

$$E_{batav} = E_{batmin} + \left(\frac{E_L}{\eta_{inv}} - E_{PV} \right) \cdot (8)$$

With E_{batmin} , the minimum level of energy allowed in the battery in kWh.

If ΔE is higher than zero, the average energy stored in the storage system can be calculated using the following equation:

$$E_{batav} = E_{batmin} + \left(E_{PV} - \frac{E_L}{\eta_{inv}} \right) * \eta_{bat} \cdot (9)$$

To protect the batteries against damage and avoid drastic reduction of its life cycle, average energy stored in the battery is subject to the given restriction:

$$E_{batmin} \leq E_{batav} \leq E_{batmax} \cdot (10)$$

E_{batmax} is the maximum level of energy allowed in the battery in kWh.

3.2.2. Average Loss of Power Supply

When the average output generated by the PV array is unable to meet the load demand and the average energy stored in the storage system is equal to the minimum allowed energy level, the average loss of power supply which represents the missing energy quantity to satisfy the load demand is calculated using relation concerned:

$$ALPS = E_L - (E_{PVav} + E_{batav} + E_{batmin})\eta_{inv}. \quad (11)$$

The Average Loss of Power Supply Probability (ALPSP) is determined by the ratio between the ALPS and the load demand:

$$ALPSP = \frac{ALPS}{E_L}. \quad (12)$$

The ALPSP varies between 0 and 1. An ALPSP value equal to 0 means that PV system will always meet the load demand, while an ALPSP value equal to 1 means that the PV system cannot satisfy the load requirements.

From the various equations, we have elaborated an algorithm. This algorithm aims to calculate the storage capacity corresponding to each PV capacity value, considering of all these operating conditions. PV capacity varies from a minimal value equal to the unitary PV module capacity, up to a maximal value corresponding to the PV power found by applying the intuitive method. The flowchart of our sizing method is given in the figure 5.

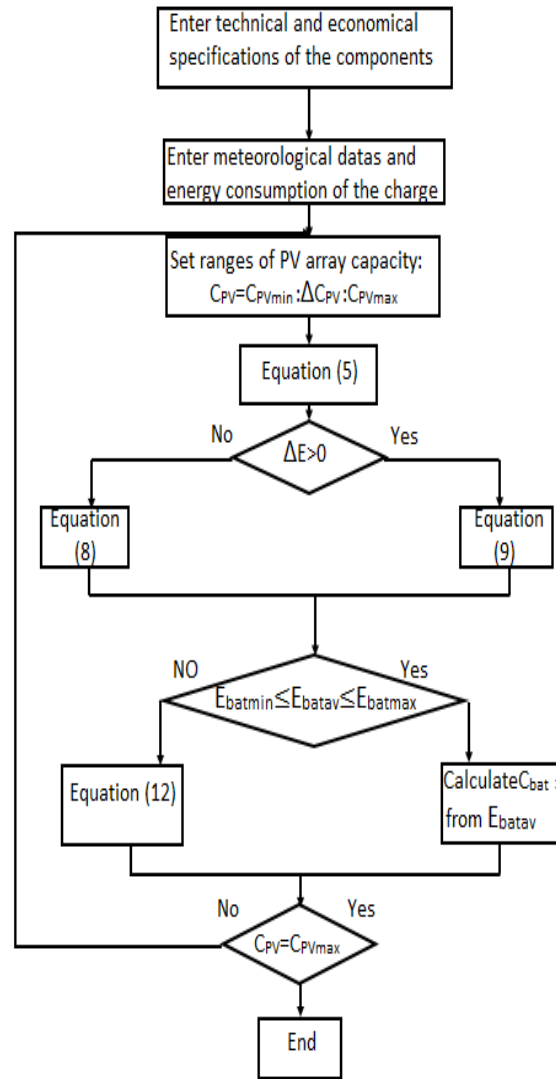

Figure 5. Calculation of the system storage capacity method

3.3. The other components sizing

The nominal power of the inverter is calculated from the maximal load consumption [11]:

$$P_{n,inv} = 1.25P_{Lmax}. \quad (13)$$

P_{Lmax} is the maximal load power.

The power of charge controller must be higher than the total PV power, its voltage must be identical to the voltage PV array. It must support an upper intensity to maximal current of PV array and load demand.

4. The economic analysis

The cost of PV system has been calculated by many researchers using different procedures, and approaches, like

net present value, life cycle cost, and levelized cost of energy [8]. To evaluate the cost of our standalone PV system, the concept of Total Life Cycle Cost (TLCC) is used. It is defined as the summation of the net present values of all the amount of the system cost such as the capital cost, maintenance and operation costs, replacement cost, etc. TLCC can be mathematically expressed as [14]:

$$TLCC = C_{capi,S} + C_{rep,S} + C_{M\&O,S}. \quad (14)$$

Where $C_{capi,S}$ is the initial capital cost of system (FCFA*) and comprises the prices of the system components, civil works, and system design and installation cost, $C_{rep,S}$ refers to the present value of the maintenance cost of system (FCFA), $C_{M\&O,S}$ denotes present value of the replacement cost of system (FCFA). The initial capital cost of the PV system is given below:

$$C_{capi,S} = c_{PV}P_{PV} + c_{bat}C_{bat} + c_{ChC}P_{n,ChC} + c_{inv}P_{n,inv} + c_{inst}. \quad (15)$$

Where c_i is the cost per unit of the i^{th} component (FCFA/unit), and c_{inv} is the cost of installation. We suppose that the PV array have a lifetime equal to the lifetime of system, 20 years, and necessitate no change, while the batteries, the inverter, and the charge controller have a less important lifetime and need replacements after some years of operating. So, the cost of replacement of the system is calculated as follows:

$$C_{rep,S} = C_{batrep} + C_{invrep} + C_{Chcrep}. \quad (16)$$

With C_{batrep} , C_{invrep} , and C_{Chcrep} being the cost of replacement of batteries, inverter, and charge controller, respectively. They are calculated by using equations (17), (18) et (19) [11]:

$$C_{batrep} = C_{batT} \left(\frac{1}{1+i} \right)^N. \quad (17)$$

$$C_{invrep} = C_{invT} \left(\frac{1}{1+i} \right)^N. \quad (18)$$

$$C_{Chcrep} = C_{ChCT} \left(\frac{1}{1+i} \right)^N. \quad (19)$$

Where N is the component's lifetime, C_{batT} , C_{invT} , and C_{ChCT} are the total capital cost of batteries, inverter, and charge controller, respectively, i refers to the market interest rate and is calculated by equation (20) [11]:

$$i = i' + \bar{f} - i'\bar{f}. \quad (20)$$

With:

f meaning inflation rate;

i' corresponding to the reel interest rates that is determined by local bank and calculated by the equation (21) [11]:

$$i' = BLR - 2\%. \quad (21)$$

BLR is the Base Lending Rates.

The Operation and maintenance cost for 20 years is calculated by [11] as follows:

$$C_{M\&O-20years} = C_{M\&O} \left[\frac{(1+i)^N - 1}{i(1+i)^N} \right]. \quad (22)$$

$C_{M\&O}$ is operation and maintenance cost for each year (1% of total initial cost) [11].

* 1Euro =650 CFA

Table 1: Technical and economical specifications of the different components of the system

Designation	Value
PV Modules 60 P 250 ^{*(1)}	1850 euros per module
Maximal Power	250 W _p
Efficiency of modules	15%
Type of cells	Polycrystalline
Size of cells	156 *156 mm ²
Nominal cell temperature (T _{NOCT}) of modules	45 +/- 1 °C
Unitary voltage of a module	48 V
Unitary cost of PV module	1.4 euros/W _c
Lifetime of PV module	20 years
Battery VICTRON open lead OPzS Solar 900 (C ₂₀)	900 Ah
Unitary voltage of battery	2 V
Depth of Discharge of battery	80%
Efficiency of battery	80%
Number of battery charge/discharge cycles	800
Unitary cost of battery	444.7 euros
Nominal cell temperature (T _{NOCT}) of batteries	45 +/-1 °C
Types of battery	Lead-acid
Lifetime of battery	5 years
Inverter SMA triphasé Tripower STP25000TL-30 with bill sticker	25000 W /230 V
Efficiency of inverter	90%
Unitary cost of inverter	4730 euros
Lifetime of inverter	10 years
Regulator VICTRON SmartSolar MPPT 250/85	48 V, (250 V /100 A)
Unitary cost of regulator	867 euros
Lifetime of regulator	10 years
\bar{f}	0.5%
BRL	3.5%

5. Results and discussions

Results obtained from the two sizing methods are recapitulated in [table 2](#) below.

[Figure 6](#) gives the variation of the total number of PV modules versus the total PV capacity obtained from the intuitive method. The total capacity required by the system is 177500 W_p and it corresponds to 710 numbers of PV

modules. In [figure 7](#), we have the variation of number of parallel connected batteries versus the storage system capacity. 48 parallel connected batteries corresponding to a capacity of 43200 Ah, are needed to meet the load demand. In this case, the total number of storage battery is 1152 batteries. The TLCC of this combination is hence 2 789 702.14 euros corresponding to 1 813 306 391 FCFA. [Figure 8](#) represents the variation of total PV capacity versus the average loss of power supply probability (reliability levels). It shows that ALPSP drops with increasing of PV capacity. Indeed, a great PV capacity enables to generate a high energy quantity and reduces the energy deficiency. [Figure 9](#) shows different combinations of PV array capacity and storage system capacity at different reliability levels obtained from the proposed numerical sizing method, called isoreliability curve. PV/battery combinations which satisfy a reliability levels of 1 and 0.01 are shown in [Figures 10](#) and [11](#), respectively. We observe that the values of PV and battery capacities in [figure 11](#), are larger than in [figure 10](#). Indeed, to obtain a lower ALPSP value and improve the reliability value, PV array and storage system capacities must be great in order to fulfill the charge requirements.

From [figure 10](#), we noted that a value of total PV array capacity of 177500 W_p necessitates a storage system capacity of 9000 Ah. If we increase this storage capacity about 20 % to take into account of the depth of allowed discharge, it grows to 10800 Ah. This capacity corresponds to 12 parallel connected batteries and a total of 288 batteries. The TLCC of this combination is 973 917.66 euros corresponding to 633 046 479 FCFA. The proposed sizing method enabled to reduce the number of battery needed by PV system to 75 % and the TLCC to 65 %, with only 0.01 of ALPSP corresponding about to four days of outage. These results confirm the effectiveness of the sizing method proposed compared to the intuitive method.

Table 2. Comparison between intuitive method and numerical method proposed

Designation	Intuitive sizing method	Numerical sizing method proposed
Total capacity of PV array	177500 W _p	177500 W _p
Total number of PV array	710	710
Total capacity of storage system	43200 Ah	10800 Ah
Total number of batteries	1152	288
ALPSP		0.01
Total number of charge controllers	9	9
Total number of inverters	4	4
TLCC	1 813 306 391 FCFA	633 046 479 FCFA

In figure 12, we plotted the PV average output energy E_{PVav} , the maximal daily energy consumption E_L , the average energy supplied by the storage system E_{batav} , and the peak energy demanded by charge during night $E_{L,night}$. We remark that the higher energy production is obtained at month of April and the lower energy generation is recorded at month of December. Moreover, for some periods of year, daily maximal load demand is larger than the generated PV system energy; in this case batteries compensate the missing

energy. We presume that the ALPSP happens during these periods. At night, since the PV array produces no energy, the filled storage system fully insures the electricity to the charge which drops strongly during this period.

Our results are in good agreement with [15] and [4]. In [5], authors did an optimal sizing of a standalone photovoltaic system for remote housing electrification, using numerical algorithm and improved system models. They used the random forest (RF) based models to model the output PV array current and a dynamic model to describe the battery behavior. Isoreliability curves and different PV/battery combinations at 0.01 LLP are presented. These results obtained by [15] are similar to ours observed in figure 9 and figure 10.

In [4], an iterative method has been used for sizing of a standalone photovoltaic system. This method combines the Loss of Power Supply Probability (LPSP) and the Life Cycle Cost (LCC) criterion. Moreover, these authors have improved the system reliability. Isoreliability curves generated are less in agreement with the obtained results in this paper compared to Ref [15]. Some differences observed are due to the component’s models as well as the nature of input parameters. Indeed, models used in [15] are more complex. In [4], the isoreliability curves give the variation of the PV module number versus battery number, while in our paper the isoreliability curves expresses the variation of PV capacity versus battery capacity. [15] and [4] integrate hourly solar irradiation and load demand data, whereas in our case, we utilized average solar irradiation and load demand data with simple energy models. This comparison confirms the validity of our method. This model is effective and can be applied when hourly data are not available.

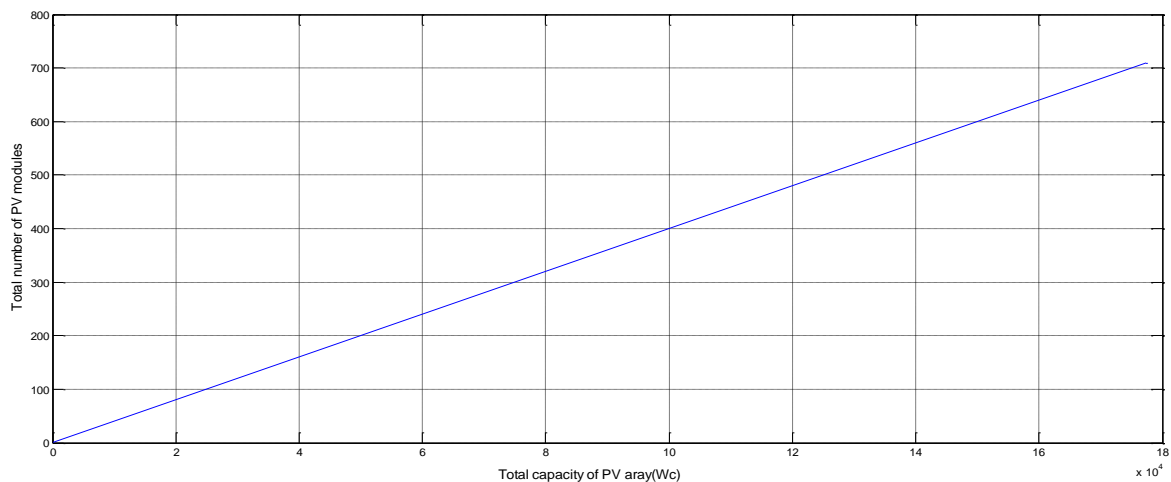

Figure 6. Variation of total PV number versus total PV capacity obtained with the intuitive method

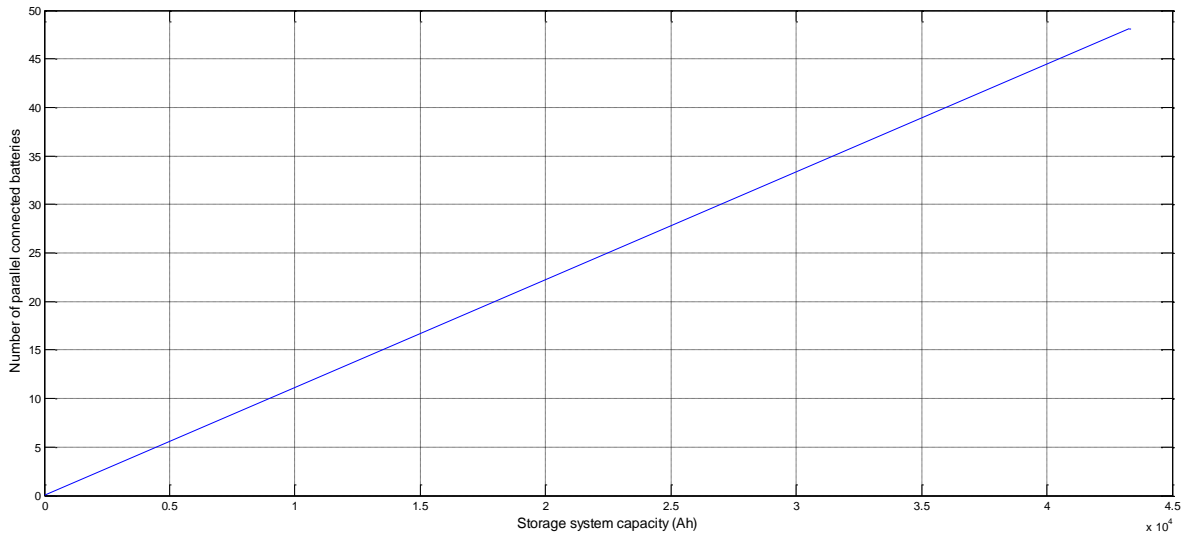

Figure 7. Variation of number of parallel connected batteries versus total storage system capacity obtained with intuitive method

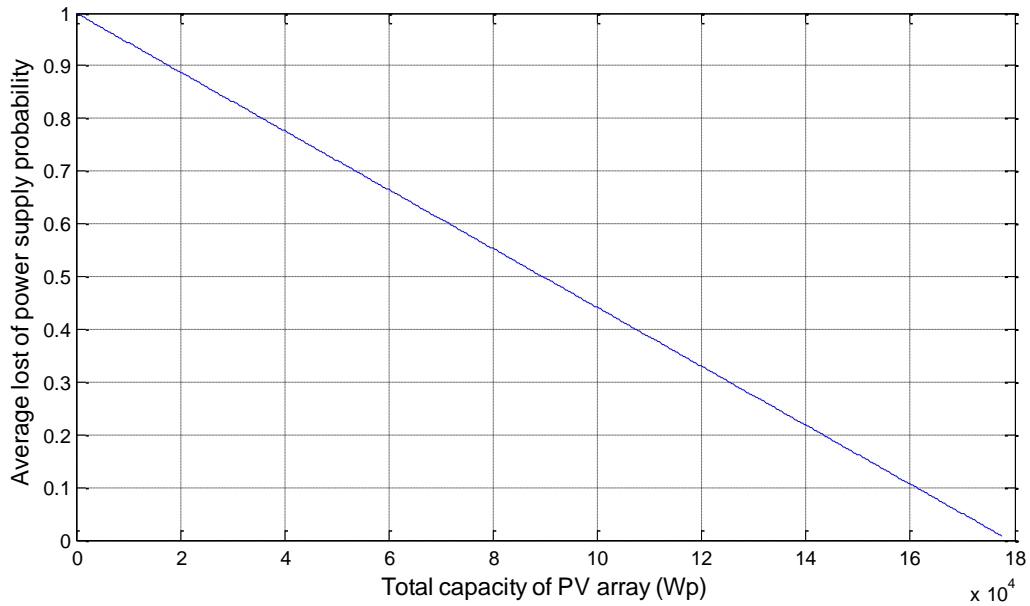

Figure 8. Variation of total PV capacity versus average loss of power supply probability

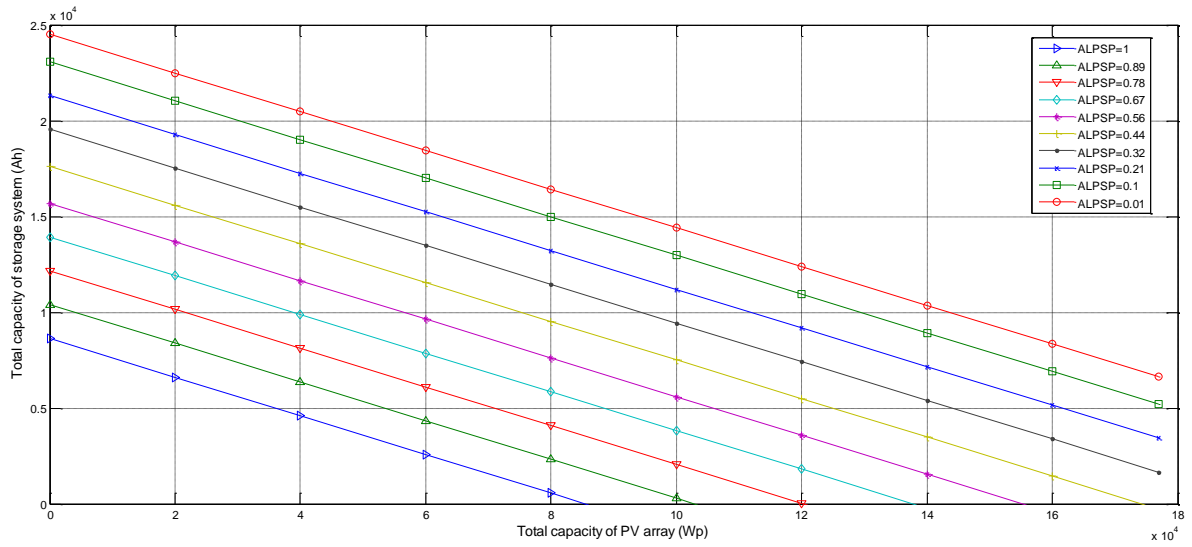

Figure 9. Different PV/battery combinations versus different values of average loss of power supply probability

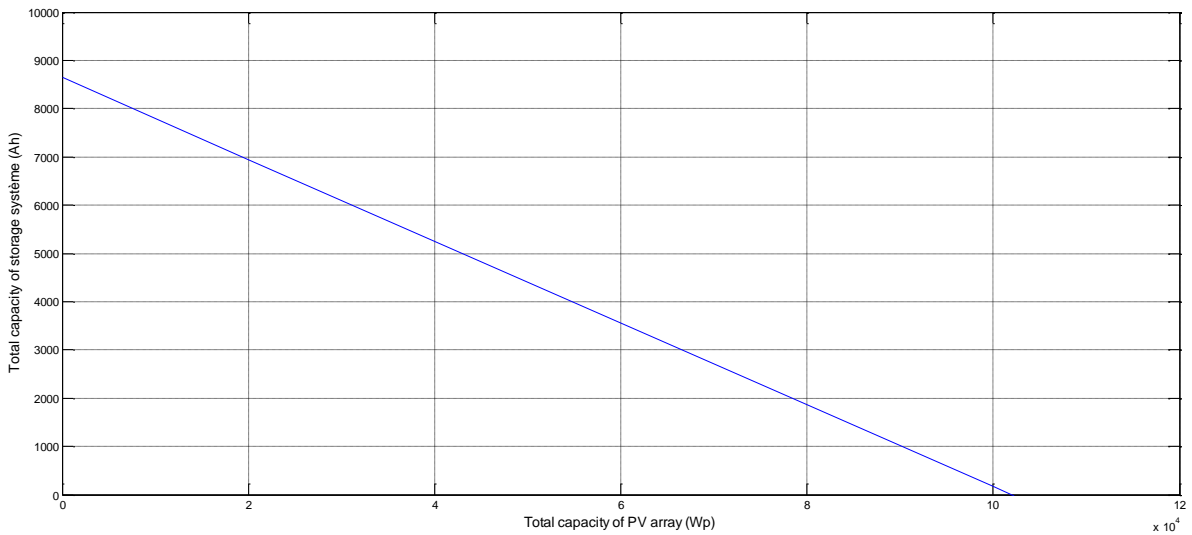

Figure 10. Different PV/battery combinations at ALPSP of 1

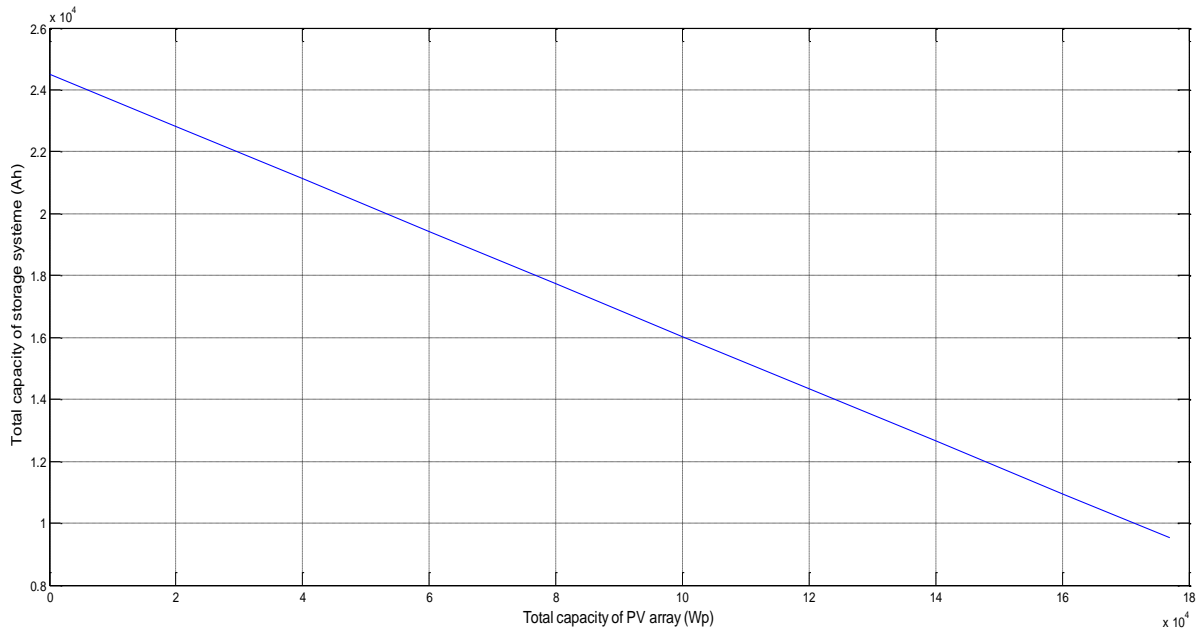

Figure 11. Different PV/battery combinations at ALPSP of 0.01

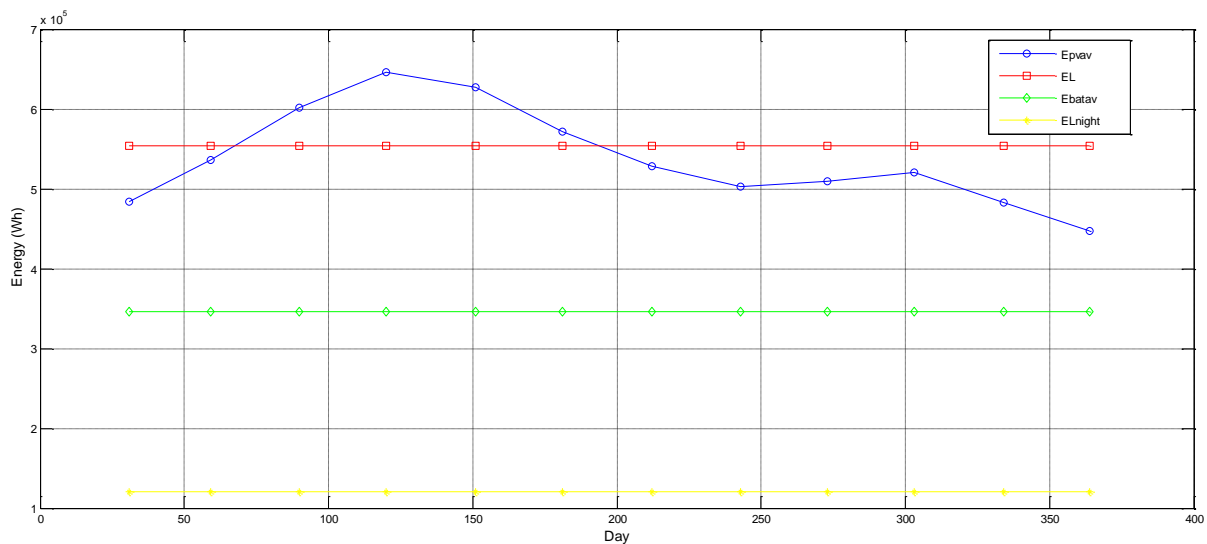

Figure 12. Annual variation of PV average output (E_{PVav}), maximal load demand (E_L), average energy supplied by batteries (E_{batav}), and maximal load demand during night (E_{Lnight})

6. Conclusion

In this paper, the optimal sizing of a standalone photovoltaic system implanted in Ngoundiane site has been treated. Criterion used for evaluating the performance of system are the Average Loss of Power Supply Probability (ALPSP) and the Total Life Cycle Cost (TLCC). As meteorological data, and load demand that we have at our disposal are of average nature, we first applied an intuitive sizing method. Issues showed that

system has been oversized and can be verified through the TLCC which is very high. To improve sizing results, we proposed a new sizing method based on determinist approach and using average input parameters. Results showed that for a same value of PV capacity, the proposed method enables to reduce the storage system capacity to 75 % and the TLCC to 65 % compared to intuitive method, with only 0.01 of ALPSP. Comparison with another paper showed the effectiveness of the proposed sizing method. It could be applied when only average meteorological data and load demand are available.

References

- [1] Adel, M. (2010) ANN based GA for generating the sizing curve of standalone photovoltaic system. *Advances in Engineering Software* **41**: 687-693.
- [2] Tamer, K., Ibrahim, A.I., Azah, M., (2016) A review on sizing methodologies of photovoltaic array and storage battery in a standalone photovoltaic system . *Energy Conversion and Management* **120**: 430-448.
- [3] Sidrach, C., Mora, L., (1998) A simple model for sizing standalone photovoltaic system. *Solar Energy Materials and solar Cells* **55**: 199-214.
- [4] Razman, A., Normazlina, M.I., Chee, W.T., components sizing of standalone photovoltaic system based on loss of power supply probability. *Renewable and Sustainable Energy Reviews*.
- [5] Adel, M., (2007) Sizing of photovoltaic system: a review. *Revue des Energies Renouvelables Vol. N°4*: 463-472
- [6] Hontoria, J., Aguilera, Z., (2005) A new approach for sizing standalone photovoltaic systems based on in neural networks. *Solar Energy* **78**: 313-319
- [7] Shen, W.X., (2009) Optimally sizing of solar array and battery in a standalone photovoltaic system in Malaysia. *Renewable Energy* **34**: 348-352
- [8] Abdul, Q.J., (2012) A novel analytical model for optimal sizing of standalone photovoltaic system. *Energy* **46**: 675-682
- [9] Hussein, A.K., Tamer, K., Sopian, K., (2013) Sizing of a standalone photovoltaic/Battery system at minimum cost for remote housing electrification in Sohar, Oman. *Energy and Buildings* **61**: 108-115
- [10] Bouabdallah, A., (2015) Safe sizing methodology applied to a standalone photovoltaic system. *Renewable Energy* **80**: 266-274
- [11] Nur, D.N., Hasimah, A.R., (2016) A novel optimization method for designing standalone photovoltaic system. *Renewable Energy* **89**: 706-715
- [12] Achaibou, A., Haddadi, M., Malek, A., (2012) Modelling of lead acid batteries in PV system. *Energy Procedia* **18**: 538-544
- [13] Achi, E., Dimensionnement optimal d'une installation solaire photovoltaïque: cas de la ferme de Tompena
- [14] Dhiaa, H.M., Hasimah, A.R., (2016) Sizing of a standalone photovoltaic water pumping system using a multi-objective evolutionary algorithm. *Energy* **109**: 961-973
- [15] Ibrahim, A.I., Tamer, K., Azah, M., (2017) Optimal sizing of a standalone photovoltaic system for remote housing electrification using numerical algorithm and improved system models. *Energy* **126**: 392-403