

# Stabilization of Electrical Parameters of Machine-Converter Voltage Source

Yu. N. Dementyev<sup>1,\*</sup>, A.V. Glazachev<sup>1</sup>, K.N. Negodin<sup>1</sup>, V. I. Susdorf<sup>2</sup>, I. Vajda<sup>1,3</sup>

<sup>1</sup>Tomsk Polytechnic University, School of Energy & Power Engineering, av. Lenina, 30, 634050, Tomsk, Russian Federation

<sup>2</sup>Komsomolsk-na-Amure State Technical University, Electric Drive and Automation of Industrial Installations, av. Lenina, 27, 681013, Komsomolsk-na-Amure, Russian Federation

<sup>3</sup>Obuda University, Kando Kalman Polytechnic, Becsi ut 96/B, 1034, Budapest, Hungary

## Abstract

The paper is devoted to development of Machine-Converter Source (MCS), which forms the output voltage waveform of electric generator as sum of EMFs with near frequencies. As electric modulation generator is used a synchronous generator and asynchronous exciter that have both common driving shaft and common housing. We studied the automatic control systems for output electrical parameters of MCS when changing speed of driving shaft and load power in wide ranges.

**Keywords:** Machine-converter sources, synchronous generator, armature winding, asynchronous exciter, PWM autonomous inverter, cycloconverter, voltage, frequency.

Received on 01 December 2017, accepted on 21 January 2018, published on 30 January 2018

Copyright © 2018 Yu. N. Dementyev et al., licensed to EAI. This is an open access article distributed under the terms of the Creative Commons Attribution licence (<http://creativecommons.org/licenses/by/3.0/>), which permits unlimited use, distribution and reproduction in any medium so long as the original work is properly cited.

doi: 10.4108/\_\_\_\_\_

## 1. Introduction

One of main goals of development of independent electrical power sources consisting of electrical machine and power semiconductor converter for autonomous power supply systems is providing electrical power, whose parameters meet quality standards, to a consumer [1]. Main quality factors of independent electrical power supply sources are parameters of output voltage, which defined by rated voltage amplitude and frequency. Deviation of the supply voltage, currents and loads is the main reason of failure of high-cost equipment. Therefore stabilizing the electrical parameters of Machine-Converter Sources (MCS) as a key component of autonomous power supply systems is topical problem.

## 2. Topologies for stabilizing parameters of MCS

We have analyzed existing methods of stabilizing output electrical parameters (amplitude and frequency of output voltage) of systems «electric generator – static frequency converter». This

analysis has shown that to form output voltage wave by means of electric generator (EG) the most promising method of the output voltage regulation for wide-range variation of the generator speed and the consumed power is voltage regulation in excitation windings of electric generator [2-4].

In this case Machine-Converter Source (MCS) can have several channels to stabilize the output voltage: by means of DC excitation winding circuit; by means of AC excitation winding circuit; by means of cycloconverter circuit. Furthermore one is able to use simultaneously two or all of the channels enabling fine varying amplitude modulation percentage and stabilizing output electrical parameters.

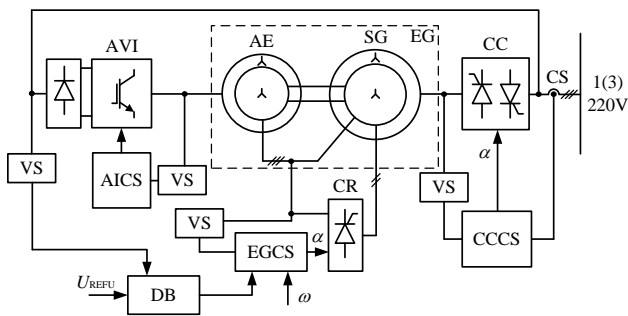
Each of stabilizing methods of the output parameters can be applied to vary output voltage of MCS by varying control angle of the semiconductor converter, which is located in armature circuit of synchronous generator. Joint use of these methods allow increasing control accuracy and expanding speed range of driving shaft for one-channel excitation system of the generator.

In the paper the following topic is considered: stabilizing electrical parameters of machine-converter source, which operates for variable speeds of prime mover.

In figure 1 a functional diagram of MCS is shown, in which the output voltage is stabilized by means of DC excitation

\* Corresponding author Yu.N. Dementyev. Email: dementev@tpu.ru

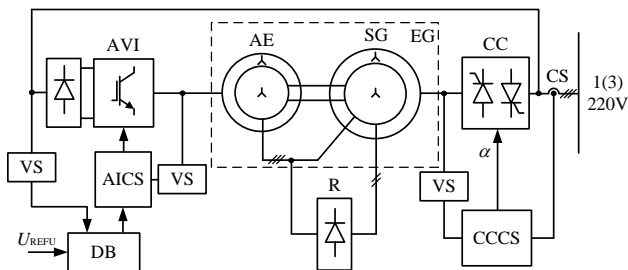
winding circuit. Here electrical generator (EG) is a modulation one and consists of two electrical machines, located in one housing of a synchronous generator (SG) with additional three-phase excitation winding wound on rotor and neither damper winding, no asynchronous exciter (AE). The generator outputs the power to three-to-one-phase cycloconverter (CC). CC has its own control system with constant firing angles ( $\alpha$ ) in rectifier and inverter mode and operates as demodulator of output voltage of generator EG, and the amplitude value of MCS output voltage is determined by the generator EG, but not by firing angle of cycloconverter CC. The firing angle of cycloconverter CC is generated subject to signals from current sensor (CS) and voltage sensor (VS).



**Figure 1.** Functional diagram of stabilizing system of the electrical output voltage parameters by means of DC excitation winding circuit

Control system of autonomous inverter (AICS) with Pulse-Width Modulation (PWM) in this case has constant reference signal of frequency and amplitude of excitation current of AE, which does not depend on output parameters of MCS. Input signals of the Electrical Generator Control System (EGCS) are: speed of driving shaft ( $\omega$ ) and reference value of voltage ( $U_{REFU}$ ), which is compared with current value of output voltage amplitude (in Difference Block (DB)). Regulation of amplitude of output voltage of autonomous machine-converter source is carried out by changing firing angle of Controllable Rectifier (CR), which feeds the circuit of DC excitation winding of generator EG.

In figure 2 a functional diagram of MCS is shown, in which the output voltage is stabilized by means of AC excitation winding circuit.

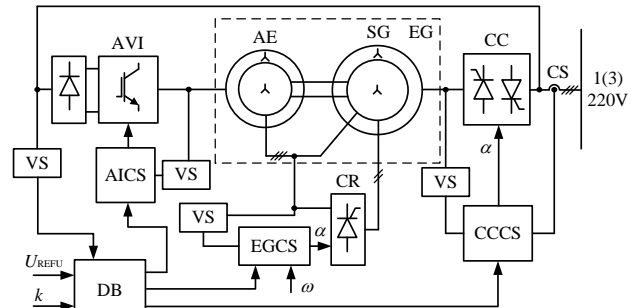


**Figure 2.** Functional diagram of stabilizing system of the electrical output voltage parameters by means of AC excitation winding circuit

Here the output voltage is regulated by means of autonomous inverter AVI, which feeds the stator circuit of

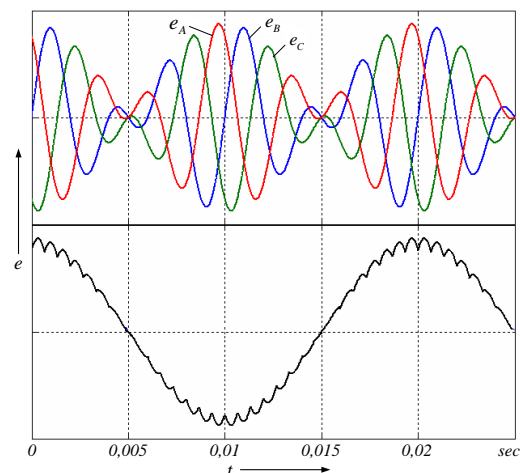
asynchronous exciter (AE). Unlike the previous method here in the DC excitation winding circuit is non-controllable rectifier (R).

In figure 3 a functional diagram of MCS is shown, which is a combination of the above considered systems stabilizing output electrical parameters of MCS.



**Figure 3.** Functional diagram of stabilizing system of the electrical output voltage parameters of combined type

In above studied functional diagrams of MCS for rotor rotation and feeding winding of AE from autonomous inverter with pulse-width modulation an EMF is induced into rotor winding of asynchronous exciter AE. In armature winding of synchronous generator an EMF is induced from DC excitation winding. Excitation winding of SG through controllable rectifier is a load for asynchronous exciter (AE). Additionally three-phase excitation winding of SG wound on rotor is also a load for AE. Sum of two EMFs induced in armature winding of SG equals to resulting EMF, whose amplitude is varying with beat frequency. As result of extraction of the output voltage envelope by means of cycloconverter CC, we got independence of beat frequency on the generator shaft speed. But here it is necessary that number of pole pairs of windings of SG have to be equal to sum of number of pole pairs of AE windings and of additional three-phase excitation winding of SG. In figure 4 are shown EMF waveforms of armature windings of generator EG and its output voltage envelope.



**Figure 4.** EMF waveforms of armature windings of generator and the output voltage envelope of MCS

Thereby, MCS that are designed according to the functional diagrams shown above (in fig. 1, 2, 3) allow to output three-phase system of modulated voltage. Extracting modulating function by means of cycloconverter CC enables to get as output voltage of MCS the one-phase voltage, which is close in waveform to sine wave. In this case the output voltage frequency will be equal to half of frequency of AC excitation current of AE and it does not depend on the generator speed.

### 3. Mathematical formulation of MCS constituted of electrical generator and static frequency converter

Modulation generators, in which output EMF is formed by extracting the envelope by semiconductor converters, are non-linear components. Therefore the whole System of Automatic Regulation of Voltage (SARV) of MCS is non-linear too. Studying stability of such systems of automatic regulation and its reaction on perturbation actions the transfer function of each electrical machine in operator format is an overdamped component [2]. Amplitude of output voltage of MCS is a sum of output voltages of the electrical machines, which is true even without taking into consideration mutual EMF inter machines constituting the generator EG. The electrical generator equation in operator format is given in terms of:

$$(mT_{d0}p+1)U_g = \frac{U_d}{n}, \quad (1)$$

where  $T_{d0}$  is time constant of excitation winding, when stator is open;  $m, n$  are factors, which characterize the generator load.

Values of factors can be determined in terms of formulae [2]:

$$\left. \begin{aligned} m &= \frac{(r_e + r_a)^2 + (x_e + x_q)(x_e + x'_d)}{(r_e + r_a)^2 + (x_e + x_q)(x_e + x_d)} \\ n &= \frac{(r_e + r_a)^2 + (x_e + x_q)(x_e + x'_d)}{\sqrt{(r_e^2 + x_e^2) + (r_e + r_a)^2 + (x_e + x_d)^2}} \end{aligned} \right\}, \quad (2)$$

where  $x_d, x_q$  are synchronous inductive impedances of the generator;  $r_a$  is resistance of stator winding;  $x'_d$  is intermediate impedance in direct axis of the generator;  $x_e, r_e$  are parameters of equivalent load of the generator.

Calculated power and all the electromagnetic loads are calculated according to first harmonics of current and voltage. Thermal load is determined by effective values of line-to-neutral currents of the generator. Because of the cycloconverter influence the load parameters in output of EG differ significantly from parameters of real load, so it is reasonable to define relationship between output current and voltage of MCS and corresponding values of EG by means of calculation several factors of the semiconductor converter. As these factors can be

used: conversion factor  $K_U$  of effective values of first harmonics of line-to-neutral voltages and conversion factor of effective values of fundamental harmonics of line-to-neutral currents. In addition, these factors allow estimating EG operation in MCS and comparing different topologies of frequency converters.

To find the factors one can use the commutation function method [7]. In this case currents and voltages of EG are given in form of trigonometric series, and conversion factors are determined by means of known spectrums.

When determining the factors the following assumptions have been made:

- load currents are sinusoidal and symmetric;
- switching of switches occurs instantly.

Spectrum of EG phase current can be presented as result of modulation of corresponding load current by commutation function given by:

$$\left. \begin{aligned} i_{AK}(t) &= i_A(t)f_K(t) \\ i_{BK}(t) &= i_B(t)f_K(t) \\ i_{CK}(t) &= i_C(t)f_K(t) \end{aligned} \right\}. \quad (3)$$

To compile commutation functions of the generator phase currents one have to determine duration of interval, when current is flowing in the generator winding. Switching on of the switches is carried out at EMF equality in two phases of generator:

$$\left. \begin{aligned} e_i &= E_{m1} \sin(\omega_0 + \omega_1)t + E_{m2} \sin((\omega_1)t + \varphi) \\ e_j &= E_{m1} \sin\left((\omega_0 + \omega_1)t - \frac{2\pi}{m}\right) + E_{m2} \sin\left((\omega_1)t - \frac{2\pi}{m} + \varphi\right) \end{aligned} \right\}. \quad (4)$$

$i = A, B, C; \quad j = A, B, C; \quad i \neq j$

where  $\omega_0$  is angular frequency of excitation voltage of AB;  $\omega_1$  is angular frequency of rotational EMF;  $m$  is number of phases of generator;  $\varphi$  is initial phase shift angle of EMF of excitation winding.

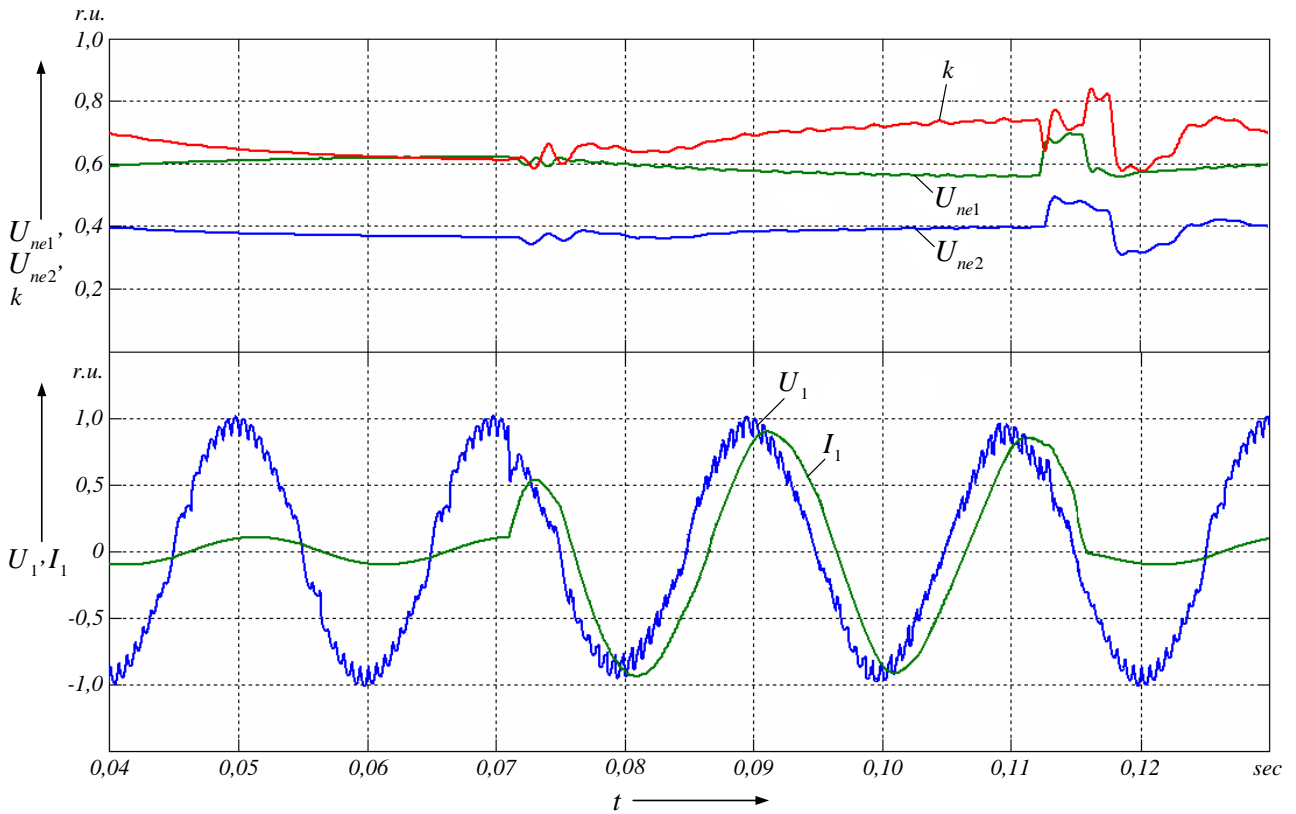
Solving the equation system (4) for we found out that the switches conduction intervals remain constant in the cycle of the modulated voltage amplitude envelope. Then commutation functions of the generator phase currents for  $m = 3$  can be determined in terms of formulae:

$$\left. \begin{aligned} f_{a1} &= \frac{4}{\pi} \sum_{n=1}^{\infty} \frac{\sin\left(\frac{n\pi}{3}\right)}{n} \cos(kn\omega_0 t) \\ f_{a2} &= \frac{4}{\pi} \sum_{n=1}^{\infty} \frac{\sin\left(\frac{n\pi}{3}\right)}{n} \cos\left(kn\omega_0 t - \frac{2\pi}{3}\right) \\ f_{a3} &= \frac{4}{\pi} \sum_{n=1}^{\infty} \frac{\sin\left(\frac{n\pi}{3}\right)}{n} \cos\left(kn\omega_0 t + \frac{\pi}{3}\right) \end{aligned} \right\}, \quad (5)$$

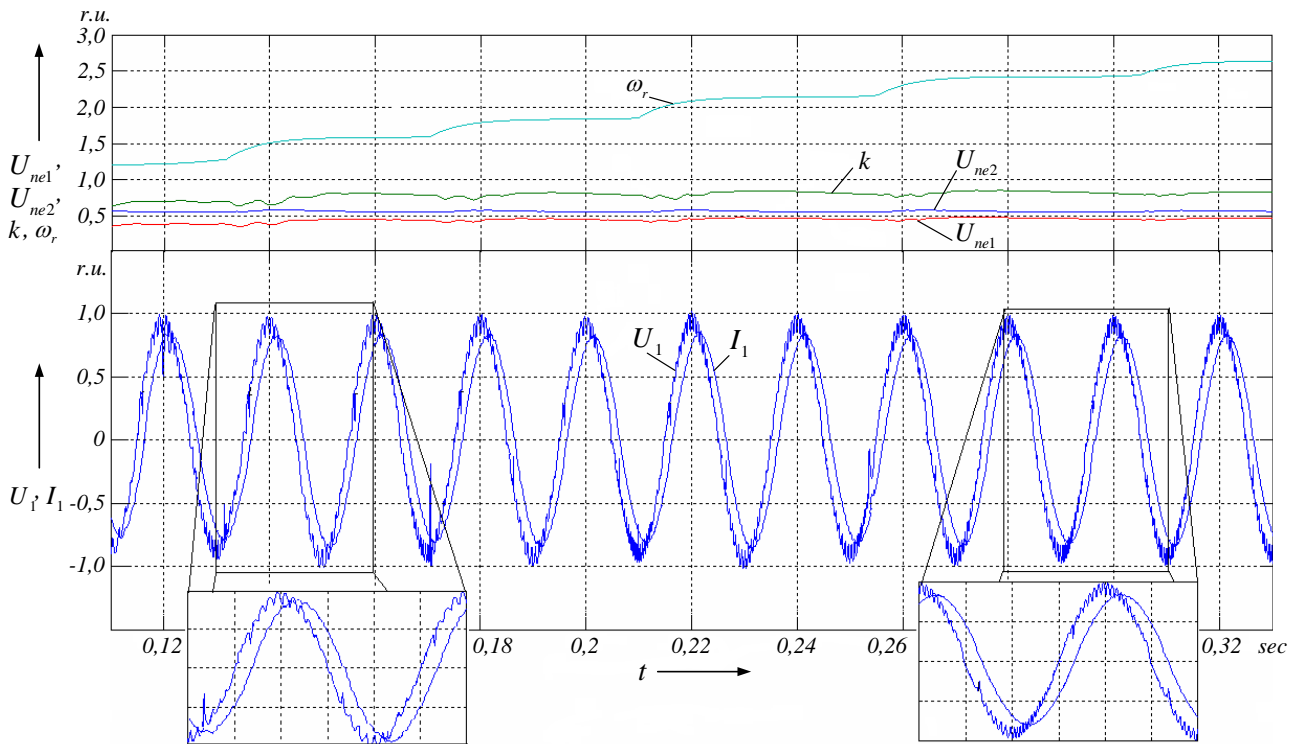
where  $n = 6k \pm 1; \quad k = 0, 1, 2, \dots$



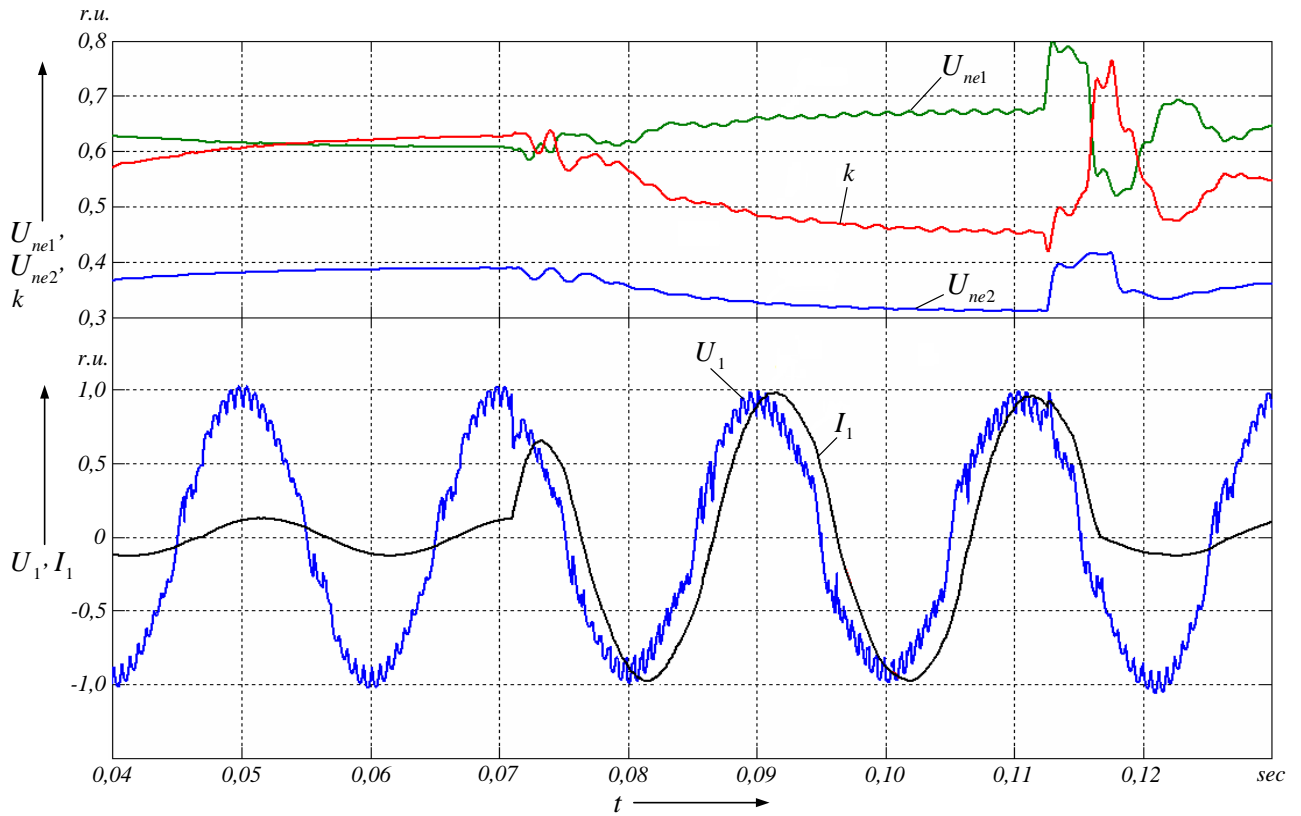




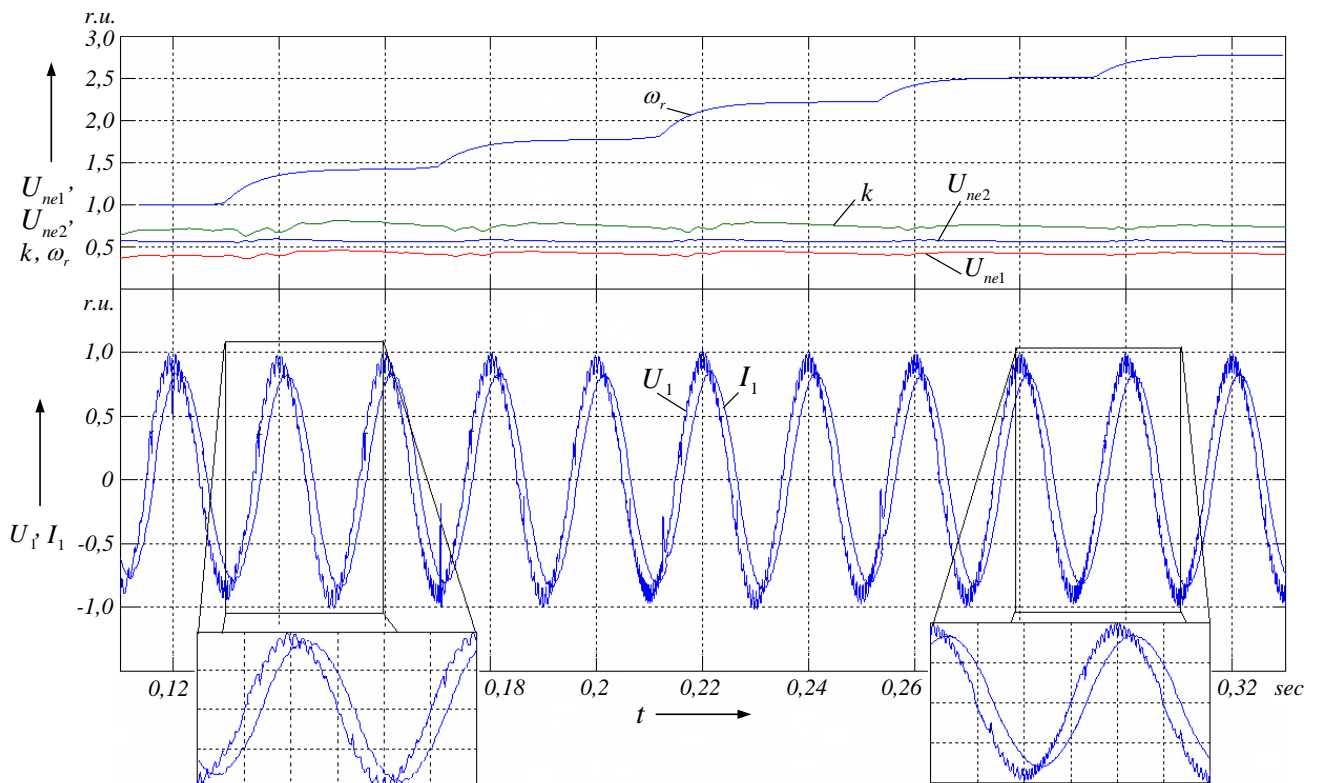
**Figure 9.** Load voltage and current waveforms of MCS when changing load power while stabilizing output electrical parameters of MCS by means of DC excitation winding circuit



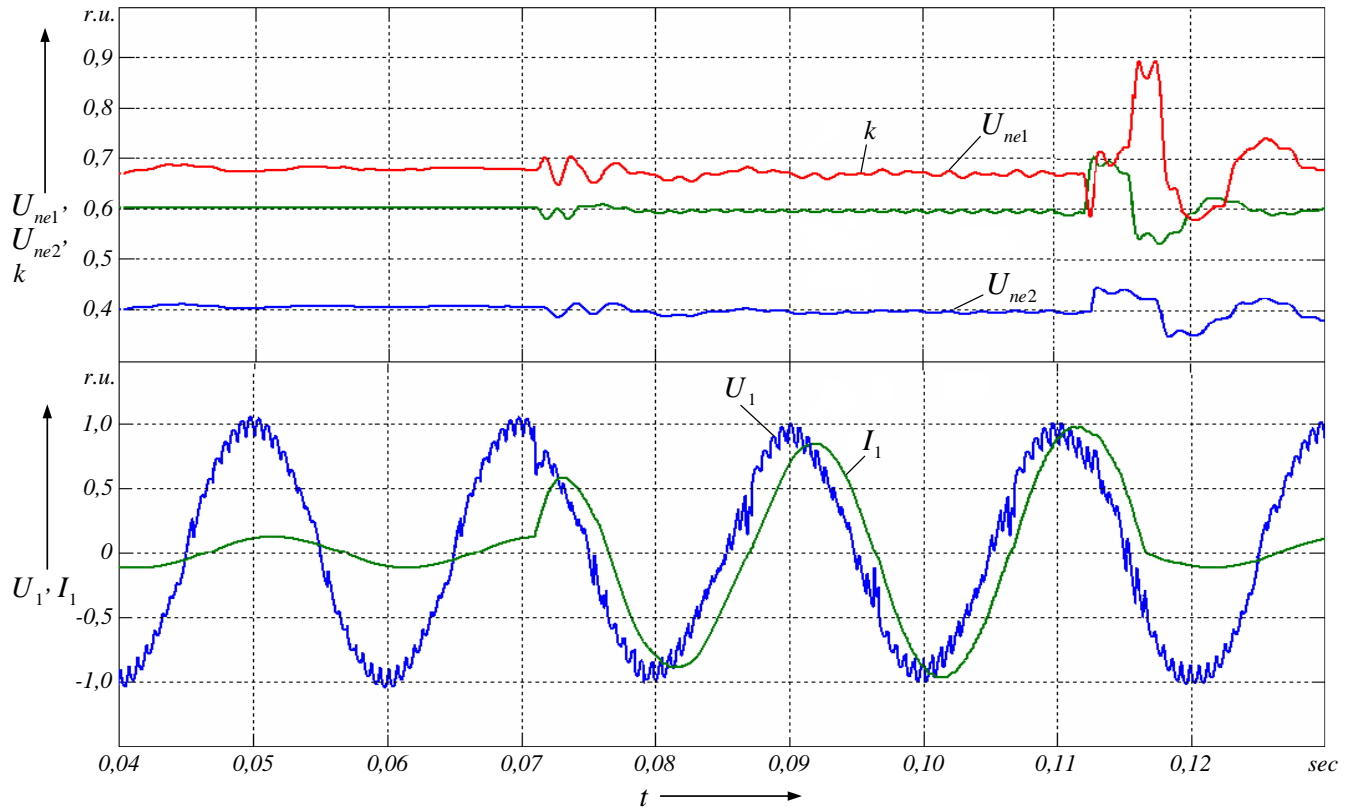
**Figure 10.** Load voltage and current waveforms of MCS when changing rotational speed of driving shaft while stabilizing output electrical parameters of MCS by means of AC excitation winding circuit



**Figure 11.** Load voltage and current waveforms of MCS when changing load power while stabilizing output electrical parameters of MCS by means of AC excitation winding circuit



**Figure 12.** Load voltage and current waveforms of MCS when changing rotational speed of driving shaft while stabilizing output electrical parameters of MCS by means of DC and AC excitation winding circuit



**Figure 13.** Load voltage and current waveforms of MCS when changing load power while stabilizing output electrical parameters of MCS by means of DC and AC excitation winding circuit

We have analyzed the simulation results and found the following:

- Using control system of output parameters of MCS by means of DC excitation winding circuit allows providing high quality of output voltage waveform even for double variation of the shaft rotation speed (figures 8, 9). However, further increase of speed causes essential deviation of the output voltage waveform from the sine wave form, and for great reducing of amplitude modulation percentage (amplitude modulation index  $k$ ) leads to square-wave-form of output voltage.

- Using control system of output parameters of MCS by means of SG AC excitation winding circuit allows maintaining constant amplitude modulation percentage index in wide range of speed variation of SG shaft (figures 10, 11). Some decrease in amplitude modulation percentage index is caused by armature response of synchronous generator SG and variation of time constant value of the DC circuit excitation winding, which is considerably more than one the AC circuit excitation winding.

- Using combined control system provides maintaining constant frequency and amplitude of output voltage in range of triple variation of rotation speed of the generator shaft (figures 12, 13) and guarantees the highest quality of the output voltage.

## Acknowledgments

Output voltage control of MCS by using only method of changing firing angle of power converter in autonomous systems poses several limitations to its use in independent sources. The reasons for these limitations are sudden far-going changes of rotational speed of driving shaft and of load power, which are characteristic for independent sources.

## Conclusions

Independent electrical power supply sources based on shaping output voltage in electrical machine allow providing high quality of the output voltage waveform, and they are prospective to apply in autonomous power supply systems.

Simulation studies of independent electrical power sources demonstrate ability to control and to maintain constant the amplitude modulation index in wide range of variation of both rotation speed of the driving shaft and load power. Besides, the research results prove that the proposed methods of stabilizing electrical parameters allow maintaining the frequency and the amplitude of the output voltage in accordance with requirements for autonomous power supply systems [9].

The research is funded from Tomsk Polytechnic University Competitiveness Enhancement Program grant, Project Number TPU CEP\_IPE\_97\2017.

## References

- [1]. Kuzmin V.M., Suzdorf V.I. Mathematical model of self-contained source with electric-machine forming of output voltage curve. Scientific notes of Komsomolsk-na-Amure State University. 2011, Vol. 1, № 5, 23-28 pp. (in Russian)
- [2]. Gujulev, E.P., Gorunov, V.N. Non-traditional renewable energy sources, OmSTU Publisher, Omsk, Russia, 2004.
- [3]. Bedri Kekezoglu, Mugdeşem Tanriöven, Ali Erduman. A New Wind Turbine Concept: Design and Implementation. Acta Polytechnica Hungarica Vol. 12, No. 3, 2015 DOI: 10.12700/APH.12.3.2015.3.12
- [4]. Abderrahmen Mechter, Karim Kemih, Malek Ghanes. Sliding Mode Control of a Wind Turbine with Exponential Reaching Law. Acta Polytechnica Hungarica Vol. 12, No. 3, 2015 DOI: 10.12700/APH.12.3.2015.3.10
- [5]. Plahina, E.G. Mathematical modeling of electromechanical-valve systems, Graduate school Publisher at Lviv University, Lviv. 164 p. 1986.
- [6]. Dubrovskiy I.N., Kuzmin V.M. AC voltage self-contained source with stable frequency based on double-machine combined generator. Bulletin of SSTU 2007 № 3 (26) 121-127 pp. (in Russian)
- [7]. Zinovev G.S. Power electronics. Moscow, Urait, 2015, 667 p. (in Russian)
- [8]. Bortsova, T.U., Lukutin, B.V. Stabilization of equivalent load on micro hydroelectric station, Proceedings of the Ninth All-Russia scientific-technical conference "Energy: ecology, reliability, safety" Volume 1, TPU Publisher, Tomsk, Russia, pp. 105-108. 2003.
- [9]. Yury Dementyev, Roman Kuzmin, Aleksandr Serikov, Viktor Suzdorf, Kirill Negodin, Istvan Vajda. Gearless Micro Hydropower Plant for Small Water-Course. Acta Polytechnica Hungarica Vol. 14, No. 4, 2017 DOI: 10.12700/APH.14.4.2017.4.9.