

# The study of the control law for carriage positioning of rodless pneumatic actuator with fuzzy regulator

D.V. Shilin<sup>1,\*</sup>, A.M. Gribkov<sup>2</sup> and V.I. Golubev<sup>3</sup>

<sup>1</sup> National Research University "Moscow Power Engineering Institute"

<sup>2</sup> National Research University "Moscow Power Engineering Institute"

<sup>3</sup> National Research University "Moscow Power Engineering Institute"

## Abstract

The objective of this paper is to present the methods of development and study of control law of rodless pneumatic actuator with fuzzy regulator in order to improve the accuracy of the pneumatic drive carriage positioning. The basis for improving the accuracy of positioning of the pneumatic actuator is the Intelligent Control System.

**Keywords:** rodless pneumatic actuator, intelligent algorithms, potentiometer, positioning, proportional valve, filter, fuzzy logic, friction.

Received on 1 August 2017, accepted on 11 October 2017, published on 21 December 2017

Copyright © 2017 D.V. Shilin *et al.*, licensed to EAI. This is an open access article distributed under the terms of the Creative Commons Attribution licence (<http://creativecommons.org/licenses/by/3.0/>), which permits unlimited use, distribution and reproduction in any medium so long as the original work is properly cited.

doi: 10.4108/\_\_\_\_\_

## 1. Introduction

Pneumatic drives are widely used in industrial automation. They are applied as actuators of clamping and transportation mechanisms. They are used in measuring devices (instrumentation), as well as in automation of machines and devices operating in aggressive conditions such as fire and explosion hazards, radiation, high level of vibrations and high temperatures.

However, pneumatic drives also have some disadvantages. In comparison with hydraulic ones (at the equal dimensions) the pneumatic drives have some difficulties in performance at low speed; air leaks also reduce their efficiency; and defined motion positioning cannot be carried out with sufficient accuracy. Despite these disadvantages, pneumatic drives are successfully used where their advantages are important.

Development of industrial automation, progress in science and technology have contributed to a significant complication of pneumatic systems. Often to serve just one machine is a whole system of connected pneumatic drives used. As a rule, kinematics of such systems is very complex and correspondingly to make decisions becomes also more complicated. Based on research we have found out that there are algorithms for controlling the carriage of a rodless pneumatic actuator, due to which, the positioning accuracy does not exceed 0.2% of the total stroke length. However, as a rule, in such systems, more than one discrete pneumatic distributor is used as the control part, so, in its turn, this significantly increases the cost of the positioning system. There are also pneumatic positioning systems with one proportional distributor, where positioning accuracy reaches 0.8% of the total stroke length. In this regard, the task of finding the algorithm to control the carriage of a rodless pneumatic drive using a single proportional distributor to increase the accuracy of positioning, is very relevant. The reasons for the low accuracy of positioning are

\*Corresponding author. Email: deninfo@mail.ru

mainly in the inability to make a high-quality control system for the pneumatic drive carriage limited only by the PID control law. Therefore, in this paper, the basis for increasing the accuracy of the positioning of the pneumatic actuator is considered to be the use of Intelligent Control Systems.

## 2. Accurate mathematical model of a rodless pneumatic actuator

In Fig. 1 the design scheme of a rodless pneumatic actuator is presented, where  $x$  - the distance of a fixed point of the piston from the origin;  $m$  - total mass of the piston and carriage;  $p_1$  - air pressure in the left cavity;  $p_2$  - air pressure in the right cavity;  $F$  - surface area of the piston;  $N$  - force of external resistance;  $f_1, f_2$  - area of the pipeline cross-section;  $p_s$  - supply pressure;  $p_A$  - atmospheric pressure;  $S$  - stroke length of the pneumatic drive carriage.

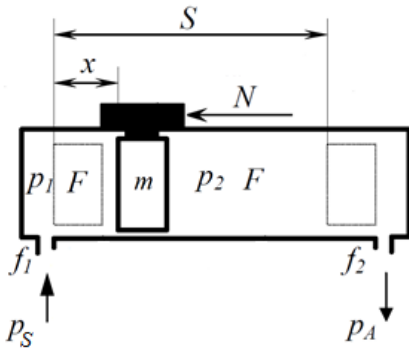

**Figure 1.** Rodless pneumatic actuator circuit scheme

The mathematical model of the pneumatic actuator is a system of differential equations describing the motion of the executive body and changing the pressures in the cavities of the actuator presented below:

$$\begin{cases} m \frac{dv}{dt} = F(p_1 - p_2) - F_{fr} - N, \\ v = \frac{dx}{dt}, \\ \frac{dp_1}{dt} = \frac{k\sqrt{RT_m} \mu_1 f_1 p_s \sqrt{\frac{2k}{(1-k)} \varphi(\sigma_1)}}{Fx + V_{1H}} - \frac{k p_1 F}{Fx + V_{1H}} \frac{dx}{dt}, \\ \frac{dp_2}{dt} = \frac{k\sqrt{RT_m} \mu_2 f_2 p_s \sqrt{\frac{2k}{(1-k)} \varphi(\sigma_2)}}{(SF + V_{2H} - V_w) p_m \frac{k-1}{2k}} - \frac{k p_2 F}{SF + V_{2H} - V_w} \frac{dx}{dt}, \end{cases} \quad (1)$$

Where  $v$  - speed of piston movement of pneumatic cylinder;  $F_{fr}$  - total resistance force arising inside the engine at the beginning of the movement and during the movement of the piston;  $\mu$  - coefficient of flow;  $\sigma = p/p_s$  - value of relative pressure;  $k$  - the adiabatic exponent;  $R$  - gas constant;  $T_m$  - gas temperature in the pipeline;  $V_w$  - working (variable) volume of the working cavity;  $V_{1H}, V_{2H}$  - "dead" volume of left and right cavities of rodless pneumatic drive.

In the technical documentation of pneumatic cylinders there is no information about the "dead" volume of the cylinder cavities, and about the full volume of the piston strips. To determine them, experimental measurements are required. Calculation of cavity volumes based on air cylinder drawings is not an optimal method. Only the installation drawings are shown in the motor data sheet. It should also be noted that in practice the effective stroke of the cylinder differs from the nominal one. The reduction in the effective stroke is due to the presence of additional damping elements at the end of the cylinder stroke, such as hydraulic and rubber dampers. Mounting the dampers on the cylinder body reduces its effective stroke and increases the "dead" volume of the piston cavities.

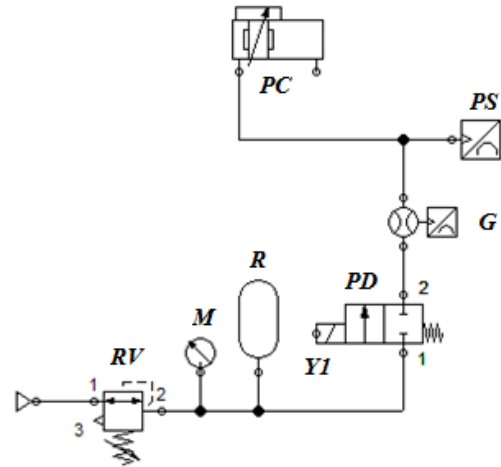

**Figure 2.** Principle pneumatic diagram of the research stand for measuring the "dead" volume

To determine them, a research stand was created, the pneumatic circuit of which is shown in Fig. 2, where the RV is a reducing valve; M - manometer; R - receiver; Y1 - electromagnet; PD - pneumatic distributor; G - the gauge of the charge; PS - pressure sensor; PC - rodless pneumatic cylinder.

To obtain quantitative results of the study of "dead" volumes, it is necessary to determine and integrate the time dependence  $Q(t)$  with the use of expression (2) [1].

$$V_H = \frac{1}{60} \sum_{i=2}^{i_{\max}} (t_i - t_{i-1}) \cdot \left( \frac{Q_i - Q_{i-1}}{2} \right) \cdot \left( \frac{p_i - p_{i-1} + 1}{6} \right) \quad (2)$$

Study of the frictional force in the pair of the piston-cylinder liner of the pneumatic cylinder and in the carriage-guide pair, as well as the determination of their quantitative value, is especially relevant, since this force acts actively on the piston, and its component enters the equation of motion of the piston of the pneumatic cylinder. The author chose the model of Ashman friction force [4], more suitable for dynamic modeling in a rodless pneumatic actuator.

To measure the value  $F_{fr}$ , a stand with program numerical control was developed, the structural diagram of which is shown in Fig. 3.

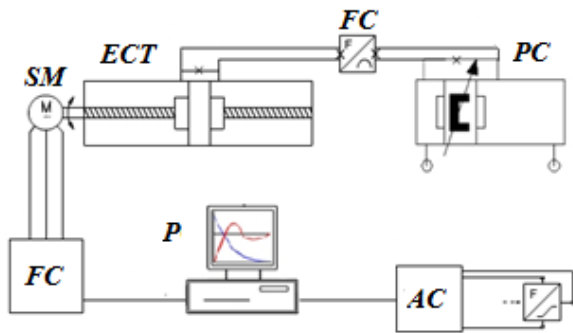

**Figure 3.** Structural diagram of the friction force test stand in a rodless pneumatic cylinder

The stand includes: PC - pneumatic cylinder, FC - force sensor, ECT - electromechanical converter of translational motion, SM - synchronous motor, FC - frequency converter, P - personal computer, AC - amplifier / converter.

Having carried out a series of experiments on measuring the frictional force in the piston-liner pairs and the carriage-guide, a characteristic of the viscous friction force for a given pneumatic cylinder was constructed [3].

### 3. System of carriage positioning of rodless pneumatic drive

To compare the results of mathematical modeling with the physical one, a laboratory stand was created, the structural diagram of which is presented in Fig. 4, where PC is a pneumatic cylinder, PS is a power supply unit, PD is a proportional distributor, C is a compressor, P is a personal computer. In the work, the rodless pneumatic drive of Festo (DGPL-25-500-PPVA) was used.

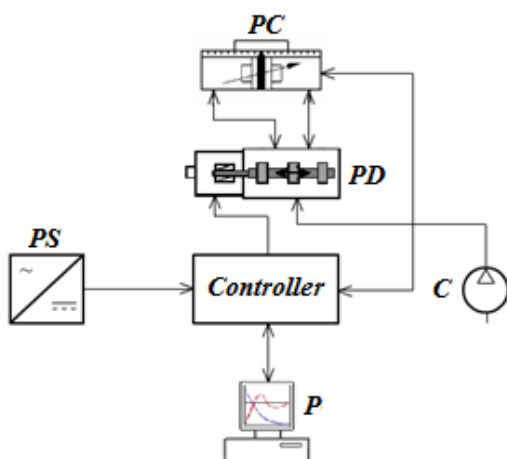

**Figure 4.** Structural diagram of the rodless pneumatic drive positioning system

The output link of the potentiometer- the position feedback sensor was fixed rigidly to the carriage of that pneumatic drive. The main problem of using this analog sensor was the noise in the output signal.

The noise was determined experimentally with a stationary carriage. To eliminate noise, two filters were developed, which showed the same results in practice. Therefore, to save the operational space of the controller, it was decided to use an averaging filter.

The use of such a filter has made it possible to reduce the positioning error component caused by noise to 0.5 mm. Also thanks to programming, the zone of insensitivity of the proportional valve was eliminated, thus the static characteristic of which took a linear form.

### 4. Development of the regulator on the basis of fuzzy logic. physical and mathematical modeling results comparison

In this paper, there was made an analysis of the control of the carriage of a rodless pneumatic drive using regulators from the classical theory of Automatic Control Systems, on the basis of which an intelligent regulator, based on fuzzy logic, is composed. Fuzzy logic is one of the forms of multi-valued logic (that is, several possible true values) and probabilistic logic (concepts true and false are considered in the range from 0 to 1, where 0 is an impossible event, and 1 practically authentic).

The conducted experiments within the framework of this work have showed that with every correction of the knowledge base and distribution zones of the membership functions, the pneumatic actuator carriage is positioned with the smallest error, however, with increasing the number of rules to 81, the system becomes oscillatory. This is due to the fact that the drive is controlled using analog control cards that have a fixed frequency which is insufficient to perform this operation correctly.

The accuracy of the positioning of the carriage of a rodless pneumatic drive depends on the behavior of the control signal near the positioning point, therefore, within the framework of this work, we studied the piecewise linear, exponential and Gaussian membership functions near the positioning point. The Figure 10 shows the transient process of the positioning error when the regulator is operated on the basis of fuzzy logic with different membership functions near the positioning point.

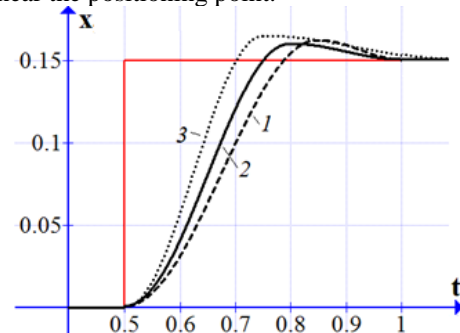

**Figure 5.** Transient process during the development of a fuzzy regulator with exponential (1), piecewise linear (2) and Gaussian function (3) near the positioning point of the pneumatic actuator carriage

As can be seen in Figure 5, the control time is the same, while the least overshoot for this controller is observed when using a piecewise-linear function near the positioning point. The most common ways of performing the defuzzification operation are to transform the membership function by the following methods: the center of gravity, the median and the center of the maxima.

Fuzzy terms from the knowledge base were configured for each of the defusion methods. In this case, transient processes were constructed in the form of the dependence of the given error on the time  $t$ . At the end of the tuning process, a graphic comparison of the results of the defuzzification on all three methods was made. The results are shown in Fig. 6.

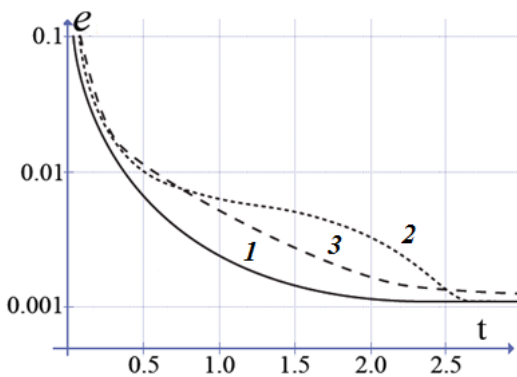

**Figure 6.** Dependence of the accuracy of the fuzzy controller on the defuzzification method: 1) the center of gravity method, 2) the median method, 3) the maximum method

As a result of the conducted research on mathematical and physical models it was established that the best indicators for the time and accuracy of the fuzzy expert system setting give the defuzzification by the method of the center of gravity.

While conventional PID controllers are sensitive to changes in system parameters, fuzzy algorithms do not need accurate information about system variables in order to be effective. Nevertheless, experiments show that PID regulators have more possibilities for monitoring and minimizing the errors of the system in a stable state. Therefore, a hybrid system was developed to take advantages of both regulators.

The Figure 7 shows the switching condition between the fuzzy controller and the PID controller, where the switch position depends on the error between the actual value and the setting point value. If the error in the positioning of the pneumatic actuator carriage reaches a value higher than the threshold, the control system applies a PID controller. When the position is below the threshold or close to the set point, the control system uses a fuzzy logic controller that has a better accuracy near the set point.

Figure 8 represents the transient process of positioning error when running the regulator based on fuzzy logic, PID controller and hybrid algorithm.

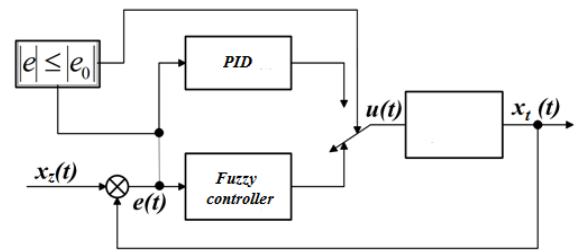

**Figure 7.** Diagram of a hybrid control algorithm for a carriage of rodless pneumatic actuator based on fuzzy logic and a PID controller

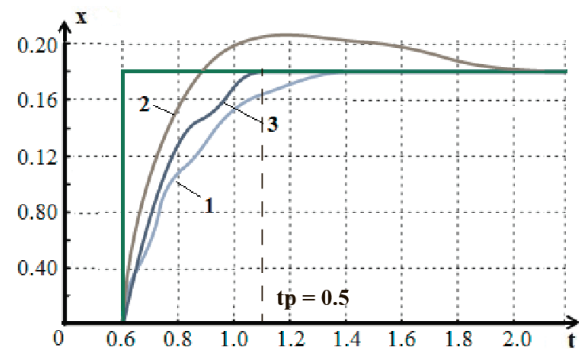

**Figure 8.** The transient process of positioning error when the regulator is operated on the basis of fuzzy logic (1), PID controller (2), and hybrid algorithm (3).

Study has shown that the hybrid algorithm (3) made possible to achieve a control time less than 0.5 sec, in contrast to the fuzzy controller, and there is no overshoot.

## CONCLUSIONS

1. The carried out experiments of studying the "dead" volumes of piston cavities, as well as the frictional forces in the piston-liner and carriage-guide pairs of the rodless pneumatic drive, clarified the mathematical model.

2. The developed mathematical model of pneumatic drive, due to its simplicity and acceptable accuracy of results, can be recommended for use in engineering calculations.

3. Study of the influence of increasing the number of rules in the knowledge base on the qualitative indicators of the transient process showed that with an increase in the number of rules up to 81 and higher, the system acquires an oscillatory feature. The study of the influence of the membership functions on the phase trajectories and the positioning accuracy has showed that the control time is the same in all the cases, with the smallest overshoot for this regulator being observed when using a piecewise linear function near the positioning point. As a result of the conducted experiments on mathematical and physical models it was established that the best indicators for the time and

accuracy of the fuzzy expert system setting give defuzzification by the method of the center of gravity.

4. In the positioning system of the carriage of the rodless pneumatic drive, in the control part of which the proportional distributor is used, thanks to the created hybrid controller it was possible to achieve the accuracy of the positioning of the output link no more than 0.4% of the total stroke length.

## References

- [1] Pneumatic actuators: Hertz E.V. (1969) *Theory and calculation*. (Moscow: Mashinostroenie).
- [2] Scientific and technical journal Mashinostroenie: Gribkov A.M., Shilin D.V. (2011) *Mathematical modeling of tripod type manipulator based on rodless pneumatic actuators*: 3-10.
- [3] Vestnik USATU: Gribkov A.M., Shilin D.V. (2013) *Study on friction force in rodless pneumatic actuator*: 246-253.
- [4] Pneumatic drives, system design, modeling and control: Beater P. (2007) (Berlin: Springer)