

## LED Driver Design for Indoor Lighting and Low-rate Data Transmission Purpose

Trio Adiono<sup>1</sup>, Syifaul Fuada<sup>1</sup>

<sup>1</sup>University Center of Excellence on Microelectronics, Institut Teknologi Bandung Jln. Tamansari, No. 126, Kampus ITB, Bandung city (40132), West Java, Indonesia

### Abstract

**Abstract**— The LED driver design for lighting at the indoor environment, as well as data transmitter with a one-way link (for download purpose), is discussed clearly in this paper. The LED driver performances are already tested with three scenarios approach and it can work properly. Those approaches are 1) single carrier signal generated by signal generator with offset null as an input signal, 2) integrated with the digital block, i.e. Digital-to-Analog converter (DAC) board which has DC component as an input signal, and 3) using the audio signal as input. The contribution in this paper i.e. 1) the LED driver was simply designed and it could be used for signal with multilevel amplitude format (e.g. audio signals, video signals, OFDM signal format, etc.); 2) low-cost platform which is built from inexpensive general DIP OP-AMP, 3) can dial up 50 kHz of bandwidth; 4) no flicker effect, therefore harmless for human eyes; 5) light weight implementation and 6) simple to operate with manual tuning. Our proposed LED driver is divided into three stages where each of them, have the main functions, i.e. a) DC-offset remover circuit to remove signal input with has DC signal characteristic, DC-offset summer circuit with a variable amplifier as signal conditioning, and voltage follower transistor.

**Keywords:** Index Terms—LED driver circuit, Low-rate data transmission, Visible Light Communication, Low-cost

Received on 18 October 2017; accepted on 7 December 2017; published on 13 December 2017

Copyright © 2017 Trio Adiono<sup>1</sup> and Syifaul Fuada<sup>1</sup> et al., licensed to EAI. This is an open access article distributed under the terms of the Creative Commons Attribution license (<http://creativecommons.org/licenses/by/3.0/>), which permits unlimited use, distribution and reproduction in any medium so long as the original work is properly cited.

doi:10.4108/xxxx

### I. INTRODUCTION

Light emitting diode (LED) technology has several advantages compared with other lighting devices (e.g. incandescent and fluorescent), such as i) have longer lifespans, ii) lower power consumption, and iii) able to use in dual function (lighting purpose as well as communication devices). Because the LED possible to switch control from mode ‘on’ to mode ‘off’ or vice versa ( $\sim\mu\text{s}$  scale) quickly. Thus, the LED has the flexibility to be controlled its illumination intensity in high frequencies using controller device [1]. Recently, this technology can be called as “visible light communication” or VLC which is an optical communication type that uses LED as transmitter device [2].

LED driver design is one of the foremost consideration for LED to be properly functioned as a dual function. Because designed LED driver is not only as power supply converter (from the  $ac$  voltage to DC voltage) but also as data modulator. LED may have poor performances as lighting sources if it uses in VLC system. This challenge is an open problem for VLC research focus in analog front-end.

In general, the topology of the LED driver can be divided into two parts, i.e. linear mode and switch mode. The LED driver based switch mode works at dim condition (‘0’ logic) and bright condition (‘1’ logic). The advantages of switch mode are high efficiency and simple circuit implementation. In another hand, the LED also have nonlinear characteristics with the polynomial curve. To make LED works in the linear region, we need to use the linear LED driver. Typically, this mode has low efficiency [3]. LED driver design is one of an interesting topic in the VLC application. Some research has been observed, such as reported by [4-8]. The Bias-tee (another name called as Bias-T) is the popular module that has been widely used as VLC’s modulator due to offers the light-weight implementation also available on the market.

This module has variety bandwidth from hundreds Hertz (Hz) till thousands. It is called “Tee” because this module has three ports (at the basic) that configured to be “T” forms, i.e. two inputs (RF and DC) and one output (RF + DC) as illustrated in Fig. 1. The Bias-T can be used to transmit an OFDM signal with high PAPR without signal partition technique [9].

The basic principle of bias T module is to add high frequency of RF signal or information signal with DC signal. Therefore bias-T module can be used as a linear LED driver due to make LED not only turn ‘on’, but also transfer the analog/digital signal. The limitation of bias-T is too expensive [10-13]. Therefore, it is unsuitable for installing the VLC system to the commercial building with mass implementation although an alternative modulator for high bit-rate data transmission system in optical communications, such as VLC.

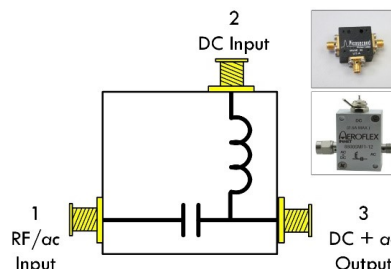

Fig. 1. Basic configuration of commercial bias-T which is consist of inductor & capacitor component, and real product Aeroflex® that retrieved from Apitech.corp. [14].

In this paper, we propose LED driver design for lighting at the indoor environment as well as data transmitter only for downloading purpose in the indoor environment. The designed its circuit is based low-cost material and can be compared with Bias-T function. Since the LED driver has developed based general operational amplifier (Op-Amp),

the data-rate transmissions relatively low due to the limited bandwidth of Op-Amp usage. The main objective of this paper focuses on the testing performance of our proposed circuit, there is no further consideration in the component selection of the circuit, *i.e.* Op-Amp.

The discussion of this paper is divided into five parts, *i.e.* introduction, circuitry design, results and analysis, conclusion, and appendix.

## II. PROPOSED CIRCUITRY

Fig. 2 shows our proposed LED driver circuit which consists of several blocks. In total, there are seven DIP Op-Amp, three 10 KΩ variable resistor, eleven 0.5 Watt metal-film resistor and one 2 Watt 2Ω resistor which configured as current protector on the collector side of the transistor. We chose LM358 Op-Amp which has 1 MHz gain bandwidth and maximum supply of -30 V<sub>DC</sub> and 30 V<sub>DC</sub>. Besides of its low cost and availability as an off-the-shelf component, this Op-Amp also compatible with our design, *i.e.* needs 12 V<sub>DC</sub> as the minimum supply voltage.

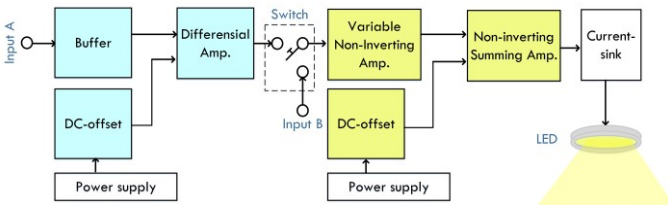

Fig. 2. Block diagram of proposed LED driver circuit for communication and illumination

The light blue colored block is a combination of DC-offset remover circuit for input signal characteristic with DC component (input-A). The yellow colored block is DC-offset adder circuit (input-B), if the input signal has a zero DC-component, it can be bypassed into this circuit. This LED driver module needs dual supply (12V<sub>DC</sub> and -12V<sub>DC</sub>).

### A. DC-Offset Remover Circuit

This circuit contains three blocks. The first block is the buffer-I circuit, which has a function to keeps information in the input signal from effects of impedance from the next circuit. Then, the second block is the DC-offset adjuster circuit, input from 12 V<sub>DC</sub> power supply can be tuned using RV1 potentiometer. Next block is the differential amplifier, which subtracts DC signal from the information signal.

For input signal with low V<sub>pp</sub> characteristic, needs to be amplified using the amplifier. But before amplified, DC component of that signal needs to be removed to avoid amplifying of DC component. Fig. 3 shows differential amplifier circuit and illustration of circuit ways of working.

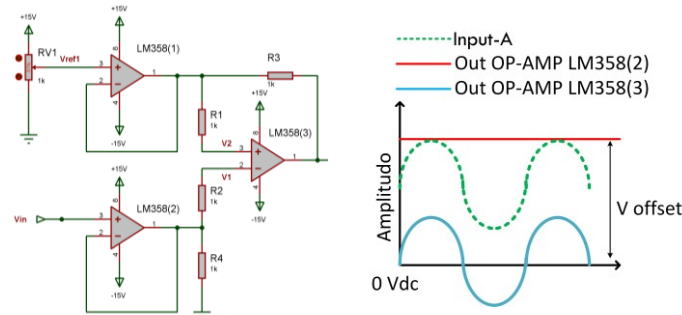

(a) (b)

Fig. 3. Circuit block for input which has DC component: (a) buffer, DC-offset remover, differential amplifier; (b) illustration of signal

Potentiometer RV1 which used to removes DC component from the input signal has to be tuned so it has characteristic, where:  $V_{adj} = 0 V_{DC}$ . This 0 V<sub>DC</sub> is a reference voltage, which means DC-offset on the input signal has been removed because it has been positioned into 0 V<sub>DC</sub>. Then, the voltage gain ( $A_{VOL}$ ) of this differential amplifier has to be ensured that low level of the output signal ( $V_3$ ) can be as close as possible to the negative saturation voltage, *i.e.* -1 V<sub>DC</sub>. If  $V1_{min} = -1 V_{DC}$  so that  $V1_{min} - V_{adj} = -1 V_{DC}$ . And  $R_3 = R_4 = R_f$ , then  $R_1 = R_2 = R_{in}$ , then if that variable inputted into the transfer function equation of differential circuit, the equation becomes equation(1),

$$V_3 = (V1_{min} - V_2) * \frac{R_f}{R_{in}} \quad (1)$$

The voltage of  $V_3$  is 2 V<sub>DC</sub>. If we choose  $R_1 = R_2 = R_{in} = 1 k\Omega$ , then  $R_f = R_3 = R_4 = 2 * R_{in} = 1 k\Omega$ . This circuit has no sinusoidal input amplifier because the output signal of the Op-Amp LM358(3) will be processed on the next circuit, which is a variable non-inverting amplifier.

### B. DC-Offset Adder Circuit

After DC component from DAC signal is removed and leaving a sinusoidal signal, the signal needs to be amplified then tuned for DC-offset to turn on the LED. Based on those ways of working, this DC-offset circuit consists of three blocks, *i.e.* non-inverting amplifier, DC-offset adjuster and summer non-inverting circuit. Fig. 4 shows the designed DC-offset circuit.

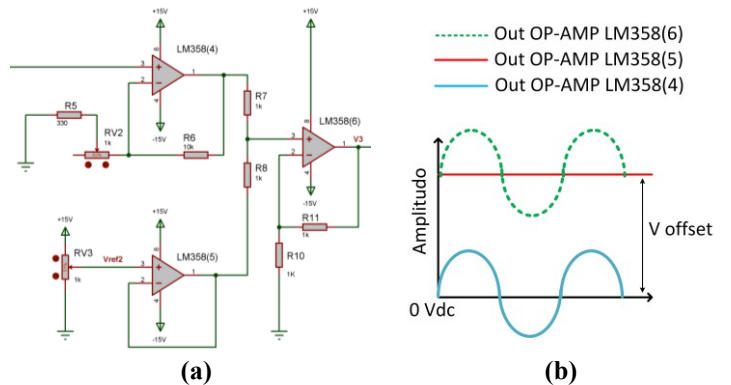

Fig. 4. Circuit block for input signal with zero DC component characteristic: (a) variable non-inverting amplifier, DC-offset adder, non-inverting summing amplifier; (b) illustration of signal

We designed a non-inverting amplifier that can be flexibly tuned, so we can get variable controlled gain of the signal. On the feedback resistor ( $R_6$ ), we put a resistor with 10 kΩ and  $R_g$  consisted of the serial connected resistor ( $R_5$  with 330 Ω resistance and RV2 with 1 kΩ resistance). Tuning of signal amplifier complied with the linear voltage of LED which is used if analog modulation is chosen. The equation(1) to

equation(3) of the signal which generated from the minimum and the maximum gain:

$$\text{Gain amp} = 1 + \frac{R_f}{R_g} \quad (2)$$

$$\text{Gain amp maximum} = 1 + \frac{10 \text{ K}\Omega}{330 \Omega + 0} = 30 \text{ times} \quad (3)$$

$$\text{Gain amp minimum} = 1 + \frac{10 \text{ K}\Omega}{330 \Omega + 1 \text{ K}\Omega} = 7.5 \text{ times} \quad (4)$$

Based on the equation(3) and equation(4), signal gain is ranging from 7.5 times to 30 times. The output voltage of Op-Amp *LM358(4)* is set for around  $4 V_{DC}$  and  $-4 V_{DC}$ . If the input signal is  $0.5 V_{DC}$ , then required gain is 8 times. Afterwards, the circuit is DC-offset adjuster to add DC component that can be tuned using potentiometer  $R_{V2}$ . The Op-Amp *LM358(5)* is configured as a buffer. The next circuit is non-inverting summer amplifier to sum the input signal from *LM358(5)* with the *LM358(4)*. The transfer function of this circuit is shown in equation(5). The purpose of this summing is to clip an output signal on the linear region of the LED. In the previous research, observation of the I-V characteristic of the white LED has been done [12]. Finally, it resulted in the conclusion that LED is the non-linear source which can affect data communication system. Then, to use analog modulation, we need proper bias, so LED can be working in its linear region.

$$V_3 = \left( \frac{R_7}{R_7 + R_8} V_{in} + \frac{R_8}{R_7 + R_8} V_{ref} \right) * \left( 1 + \frac{R_{11}}{R_{10}} \right) \quad (5)$$

Where  $V_3$  is an output voltage of non-inverting summer amplifier circuit. If,  $R_7 = R_8 = R_{10} = 1 \text{ k}\Omega$ , then equation(5) can be rewritten as equation(6).

$$V_3 = (0.5 * V_{in} + 0.5 * V_{ref}) * \left( 1 + \frac{1 \text{ K}}{R_g} \right) \quad (6)$$

Suppose that peak-to-peak voltage ( $V_{pp}$ ) of the previous signal input is  $4V_{DC}$  to  $-4V_{DC}$ . Then, the LED voltage for the linear region is  $8 V_{DC}$  to  $12 V_{DC}$ , it means we only need single gain. But, in the equation(6), the input signal has 0.5 of gain ( $0.5 * V_{in}$ ), thus the signal automatically reduced by half and need double gain. Therefore, the output signal still at  $4 V_{DC}$ . Other than that, DC voltage reference also had a 0.5 gain. So, the value of resistor  $R_{11}$  is  $1 \text{ k}\Omega$ , as explained in the equation(7).

$$\left( 1 + \frac{R_{11}}{1 \text{ K}\Omega} \right) = 2 \text{ times, then } \left( \frac{1 \text{ K}\Omega}{1 \text{ K}\Omega} \right) = 1 \text{ times} \quad (7)$$

### C. Voltage Follower

The last circuit stage is Voltage follower as shown in Fig. 5. As has been explained on the section-2, that is required Op-Amp needs to be supplied with the minimum voltage of  $12V_{DC}$  and  $-12V_{DC}$ , it is because the equation that we used is LED voltage equal to sum of DC component with the sinusoidal input signal which has been amplified as

shown in equation(8) and equation (9). The RF transistor 2N3866 is used, it has a typical switching frequency of 400 MHz. This type is suitable for low, middle as well as wide range of VLC bandwidth.

Suppose that  $V_{LED}$ , which is maximum voltage to supply LED, is  $12 V_{DC}$  and  $V_{in} = 4 V_{DC}$ , so  $V_{ref} = 6 V_{DC}$ .

$$V_3 = V_{LED} \quad (8)$$

$$V_{LED} = (0.5 * V_{in} + 0.5 * V_{ref}) * (2) \quad (9)$$

$$V_{LED} = (1 * V_{in} + 1 * V_{ref}) \quad (10)$$

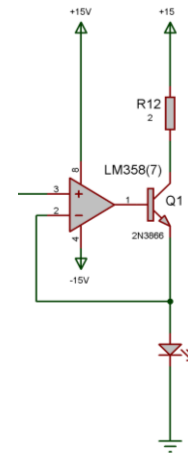

Fig. 5. Voltage follower at LED driver

## III. RESULTS AND ANALYSIS

### A. Evaluation Procedure

There are three scenarios that used to functional test of our proposed circuit. First, we use single carrier sinusoid signal generated by the signal generator (GW INSTEK GFG-8210) with  $1 V_{pp}$  of amplitude without DC-offset as shown in Fig. 6. This scenario purpose is to observe the bandwidth of the LED driver circuit and also perform LED driver if the input signal has no DC component.

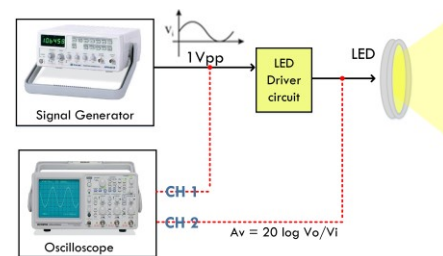

Fig. 6. Test scenario to observe cut-off frequency of the LED driver, testing is done using sinusoidal input signal and output gain voltage calculated using equation  $20 * \log (V_o/V_i)$

Second is input signal with DC component as shown in Fig. 7. This scenario purpose is to measure LED driver performances for VLC based on digital processing via PC to PC. As the material, we use Digital to Analog Converter (DAC) THS5651EVM board from Analog Devices. Inc. The detailed system on chip design on this FPGA is discussed in [15].

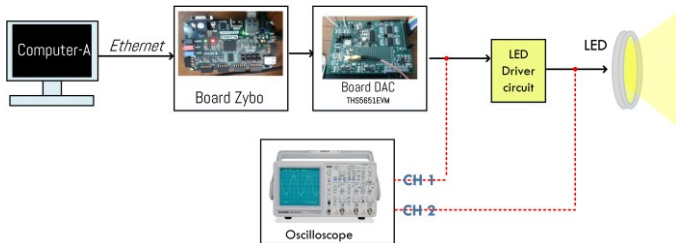

Fig. 7. Set-up of the second scenario

The third is using audio as an input signal as shown in Fig. 8. In the third scenario, we use music audio file with MP3 format to be transmitted from the laptop to the loud speaker.

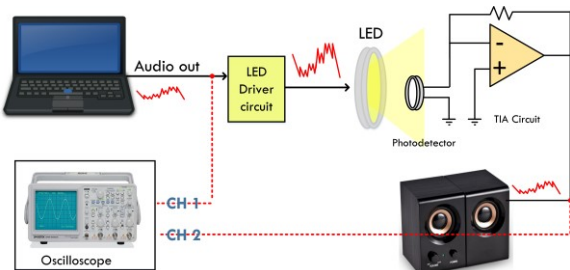

Fig. 8. Set-up of the third scenario

**B. Simulation Results**

A circuit simulation has been done by using the MULTISIM® software tools as shown in Fig. 9, it shows that our proposed LED driver circuit working as have been designed. The LED is on and also transmit sinusoid signal.

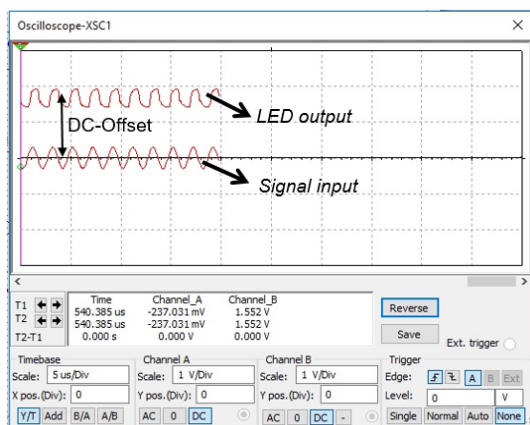

Fig. 9. Captured signal on the virtual oscilloscope of MULTISIM V.14, it shows a comparison between the input signal (without DC-offset) with anoda channel of the LED. The parameters used, i.e. single carrier signal = sinusoid form, Amplitude = 0.5 Vpp, input frequency = 100 kHz)

**C. Printed Circuit Board (PCB) Implementation**

The implemented of designed LED driver is shown in Fig. 10(a) for DC-offset remover circuit, and Fig. 10(b) for DC-offset adder and voltage follower circuit where its configuration is developed by Fig. 2. Due to the objective of this paper is for research purpose, both modules are fabricated in separate for easy testing with *plug and play*. Therefore, we can adapt the characteristic of the input signal (with or without DC). Each of modules is supplied by the dual power supply, i.e.  $V_{CC}$ ,  $ground$ , and  $V_{EE}$ . Then, the input channel has five ports, i.e.  $V_{CC}$ ,  $ground$ ,  $V_{EE}$ ,  $data$ , and  $ground$ . The proposed LED driver is developed by Proteus

7.0 Student version software based double layers PCB. All of components used is discrete with inexpensive.

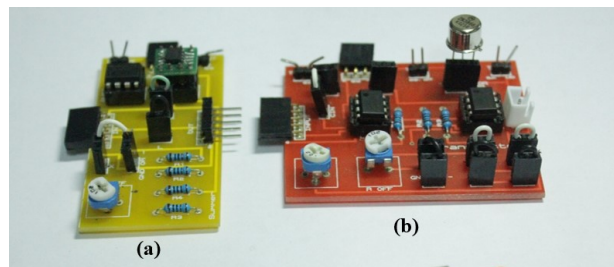

Fig. 10. A Photograph of LED driver module: (a) the Tx-B module with specific dimension 33.32mm x 62.56mm; (b) the Tx-A module with specific dimension 49.96mm x 61.85mm;

**D. First Scenario**

The first step that needs to be done before doing data transmission is observing the frequency response of the LED driver circuit. The experimental procedure is shown in the Fig. 5., the signal transmitted from frequency generator with varied frequency from 1 kHz to 100 kHz, then the output of the Op-Amp LM358(7) probed to observe the frequency attenuation. Fig. 11 is a graph of  $A_{VOL}$  (dB) relationship with frequency, in a logarithmic scale. It can be known that the cut-off frequency of the LED driver circuit is around 75 kHz.

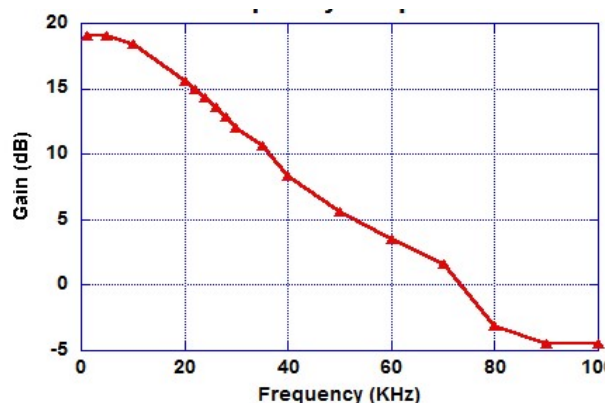

Fig. 11. LED driver bandwidth, frequency is ranging from 1 kHz to 100 kHz

According to Fig. 6, that signal input is tuned with null offset (no DC component). We use the input frequency with 10 kHz and amplitude of  $1 V_{pp}$ , which is the minimum voltage for LED to be turned on. Fig. 12(a) shows the measured signal of the input of LED driver circuit (indicated by the blue signal) against an output signal of the variable non-inverting amplifier stage with 10 times gain (indicated by the yellow signal). Fig. 12(b) shows the measured output signal of Op-Amp LM358(4) that indicated by the blue signal against  $V_{LED}$  that indicated by yellow signal.

The results shows that variable non-inverting is working correctly. The non-inverting summer amplifier sums the DC signal with the output signal of Op-Amp LM358(4) as well as amplifying the signal 2 times after attenuated in half.

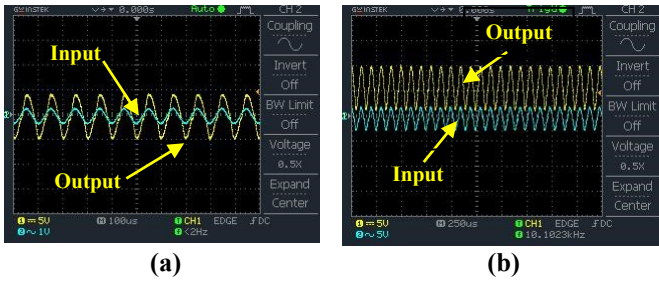

Fig. 12. Oscilloscope measured output signal of LED driver in the first scenario

### E. Second Scenario

We perform the second scenario based on Fig. 7. Then, Fig. 13(a) shows the measured signal of the LED driver input from DAC THS5651EVM module that indicated by the blue signal) against the output signal of Op-Amp LM358(3) that indicated by the yellow signal. It shows that blue signal as input has a DC component then rejected, finally it shown that output (indicated by the yellow signal) has no DC. Then Fig. 13(b) shows the measured signal of the output of Op-Amp LM358(4) with  $V_{LED}$  (indicated by the blue signal).

These results show that DC-offset remover can remove the DC component from the signal output of DAC THS5651EVM module, and non-inverting summer amplifier can tune the DC-offset to turn on the LED in the linear region.

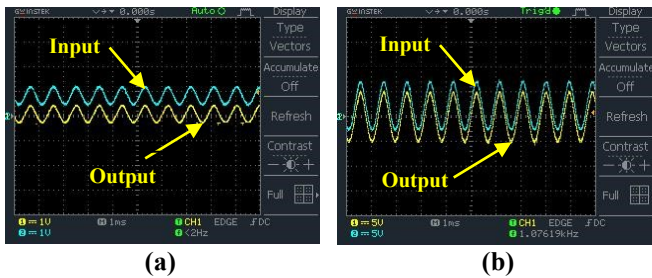

Fig. 13. Signal measured by the oscilloscope from the output of the LED driver for the second scenario

### F. Third Scenario

As stated before, we tested LED driver to transmit an audio signal from PC. The audio signal is an analog signal with a low-frequency characteristic which is suitable for the testing input signal. Besides that, the transmission is one-channel only so it can be processed using the designed system. It different than video signal with two-channel communication (audio and video channel) so it needs two transceivers. The measurement scenario is refer to Fig. 8.

The required components are audio jack output for PC, audio jack cable, photodiode, Op-Amp receiver circuit and loud speaker to produce the output signal. The testing method is by playing music audio on the PC then the output signal processed by the analog transmitter circuit and converted into the visible light. Then, on the receiver side, photodiode captured the signal to be processed by the AFE circuit and then outputted in the loud speaker. The laboratory tested is shown in Fig. 14.

The experiment of audio transfer experiment is explored and described in [16-17].

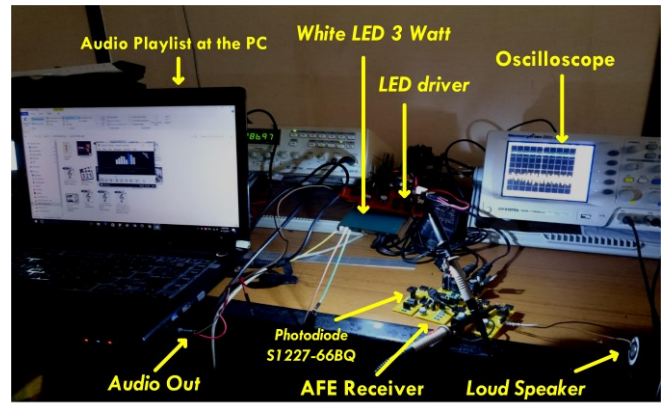

Fig. 14. Measured signal of LED driver in the third scenario

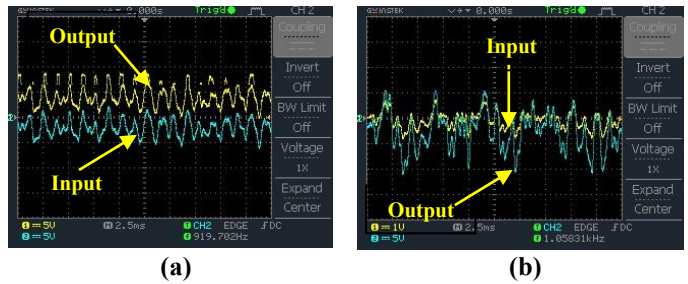

Fig. 15. Measured signal of LED driver in the third

We compare the signal output from non-inverting variable pre-amp (indicated by the blue signal) and LED (indicated by the yellow signal) as shown in Fig. 15(a). Comparison of the signal between LED and TIA's circuit output is shown in Fig. 15(b). These results show that audio signal can be transmitted and outputted from the loud speaker with good quality with distances of the sensor is less than 50 cm and elevation degree of  $0^\circ$ .

## IV. CONCLUSION

Recently, the LED beside can be used for room illumination also can be used for data transmission. In this paper, we propose a LED driver circuit design for indoor lighting as well as for data transmission. We consider the LED main function, as the lighting device. Therefore special consideration was implemented in circuit design.

The proposed LED driver circuit consists of several blocks, *i.e.* buffer circuit I, DC-offset remover, differential amplifier, non-inverting amplifier, buffer circuit II, DC-offset adder, non-inverting summer amplifier and voltage follower. Using this circuit, LED which usually used for lighting can have added value, because it can also be used to transmit data.

According to evaluation, we conclude that our proposed LED driver can be used for signal input with and without DC and also audio signal broadcasting. The lighting product is without flicker, has bandwidth up to 50 kHz, and the circuit can work properly to be replaced the Bias-T performance with low-cost material. Our proposed circuit has a linear LED driver typical, thus it also can be used to transmit OFDM signal. However, it must be a low-frequency since the Op-Amp has limited bandwidth.

The limitation in this design is only for low-rate data transfers. For larger bandwidth, this design needs a higher

specification of Op-Amp. For example specific purpose Op-Amp with high-bandwidth.

## REFERENCES

- [1] S. Fuada, "Design and Implementation of Analog Front-End Transceiver Module for Visible Light Communication System", Master's Program Thesis, Institut Teknologi Bandung. May 2017.
- [2] P. Chanthosot, *et al.*, "The Indoor Use Development for Visible Light Communication," *Proc. of the World Congress on Engineering and Computer Science (WCECS)*, Vol. 1, October, 2015.
- [3] T. Adiono, S. Fuada, A.P. Putra, and Y. Aska, "Desain Awal *Analog Front-End Optical Transceiver* untuk aplikasi *Visible Light Communication*," *J. Nasional Teknik Elektro dan Teknologi Informasi (JNTETI)*, Vol.5 (4), pp. 319-327, November 2016. DOI: [10.22146/jnteti.v5i4.280](https://doi.org/10.22146/jnteti.v5i4.280).
- [4] A. Ahmed *et al.*, "A High Speed Transmitter for Visible Light Communications up to 50 Mbps," *Proc. of Int. Conf. on The Emerging Technologies (ICET)*, January 2015.
- [5] H. Li, *et al.*, "An Analog Modulator for 460 Mb/S Visible Light Data Transmission based on OOK-NRZ Modulation," *IEEE Wireless Communications*, pp. 68-73, April 2015.
- [6] Z. Jia, L. Shen, W. Xia, and M. Wu, "Experimental Demonstration of Pulse Amplitude Modulated Visible Light Communications," *Proc. of The IEEE 3<sup>rd</sup> Global Conf. on Consumer Electronics (GCCE)*, pp. 727-728. February 2015.
- [7] C-S.A. Gong, *et. al.*, "The High-efficiency LED Driver for Visible Light Communication Applications," *Nature Scientific Reports* 6, Article number: 30991, pp. 1-7, August 2016.
- [8] A. Mirvakili and V. J. Koomson, "High Efficiency LED Driver Design for Concurrent Data Transmission and PWM Dimming Control for Indoor Visible Light Communication," *Proc. of 2012 IEEE Photonics Society Summer Topical Meeting Series* pp. 132-133, August 2012.
- [9] Y. Zhou, Y. Wu and H. Wu, "Reducing Peak Transmission Power of OFDM System Using Signal Partition Technique," *Engineering Letters*, Vol. 23(3), EL\_23\_3\_12, July 2015.
- [10] B.Hicks and B. Erickson, "Bias-T Design Considerations for the LWA," [Online], available at <http://www.phys.unm.edu/~lwa/memos/memo/lwa0135.pdf>. pp. 1-16, May 2008.
- [11] C-S.A. Gong, *et. al.*, "The High-efficiency LED Driver for Visible Light Communication Applications," *Nature Scientific Reports*, 6:30991, pp. 1-7, DOI: [10.1038/srep30991](https://doi.org/10.1038/srep30991).
- [12] S. Fuada, T. Adiono, A.P. Putra, and Y. Aska, "A Low-cost Analog Front-End (AFE) Transmitter Designs for OFDM Visible Light Communications," *Proc. of Int. Symposium on Electronics and Smart Devices*. November 2016.
- [13] S. Fuada, "Design and Implementation of Analog Front-End Transceiver Module for Visible Light Communication System," M.T. thesis, Dept. Elect. Eng., School of Electrical Engineering and Informatics, Institut Teknologi Bandung, Bandung, Indonesia, 2017.
- [14] T. Adiono and S. Fuada, "Desain dan Implementasi LED Driver *Linier* untuk Aplikasi *Visible Light Communication*," *Unpublished*.
- [15] A. P. Putra, S. Fuada, Y. Aska, and T. Adiono, "System-on-Chip Architecture for High-Speed Data Acquisition in Visible Light Communication System," *Proc. of the IEEE Int. Symposium on Electronics and Smart Devices (ISESD)*, pp. 63-67, March 2017. DOI: [10.1109/ISESD.2016.7886693](https://doi.org/10.1109/ISESD.2016.7886693)
- [16] S. Fuada, A.P. Putra, Y. Aska, and T. Adiono, "Short-range Audio Transfer through 3 Watt White LED based on LOS channels," *Unpublished*.
- [17] S. Fuada, and T. Adiono, "Rancang Bangun Layer Fisik Visible Light Communication Pada Sistem Transmisi Audio," *J. INFOTEL*, Vol. 9(3), August 2017. doi: <https://doi.org/10.20895/infotel.v9i3.288>.

**Trio Adiono** obtained his Ph.D. degree in VLSI Design from Tokyo Institute of Technology, Japan, in 2002. He received the "Second Japan Intellectual Property Award" in 2000 from Nikkei BP for his research on "Low Bit-rate Video Communication LSI Design". He also holds a Japanese Patent on "High Quality Video Compression System". Currently, he is a lecturer at the School of Electrical Engineering and Informatics, a Head of the Microelectronics Center and IC Design Laboratory, ITB. He currently serves as a chair of the IEEE SSCS Indonesia Chapter. His research interests include VLSI, Signal and Image Processing, Visible Light Communication, Smart Card, Electronics Solution Design and Integration.

**Syfaul Fuada** received B.Ed degree on Electrical Engineering Education major from Universitas Negeri Malang (UM), Indonesia in 2014/2015 and M.Sc degree on Electrical Engineering, Microelectronic option, Institut Teknologi Bandung in 2016/2017. Now he is working at PME ITB. He holds two pending patents (helmet charger based solar energy and out-pipe inspection system based mobile robot) and several achievements such as, the best poster in SPRINT 2014, one of the 106 Indonesian Innovators by BIC-RISTEK DIKTI in 2014, the best poster in KIPNAS XI in 2015, student travel grant in IEEE APCCAS 2016, and one of 108 Indonesian Innovators by BIC in 2016. His research interests include: Analog circuits design, instrumentation system, circuit simulation, engineering education, multimedia learning, and visible light communication.