

Simulation Modes Of Relay Protection Devices In Networks With Insulated Neutral

Smagulova K.K.^{1*}, e-mail: smagulovakk@mail.ru, Iskakov U.K.².

¹Karaganda State Technical University, No.56, Mira B., Karaganda, 199927, Kazakhstan

²Karaganda State Technical University, No.56, Mira B., Karaganda, 199927, Kazakhstan

Abstract

This program was developed as a universal model of typical devices for protecting electrical networks with insulated neutral. Imitation experiments are executed by the design of working operating and emergency modes. It has been established as in real-world conditions with unselective wearing-outs of protecting as possible.

Keywords: the network with the insulated neutral, current protected devices, the model of electrical network with the insulated neutral, operating conditions, nonselective triggering

Received on 17 October 2017; accepted on 13 November 2017; published on 13 December 2017

Copyright © 2017 Smagulova K.K and Iskakov U.K, licensed to EAI. This is an open access article distributed under the terms of the Creative Commons Attribution license (<http://creativecommons.org/licenses/by/3.0/>), which permits unlimited use, distribution and reproduction in any medium so long as the original work is properly cited.

doi:10.4108/xxxxxx

1. Introduction

Power systems are exposed to damage and abnormal operated modes. The main reasons of damage are: the violations of isolation current parts, overvoltage, mechanical damage, damages of wires and supports electricity transmission line, connecting with their unsatisfactory state, ice surface and etc. [1].

For protecting power systems from damage and abnormal modes of work are used the different types of relay protection and automation. However, in the process of exploitation power grid there are many situations, leading to the non-selective protection of operation work. The most common situations include the fluctuations of voltage in the mining industry where powerful electro-consumers are: fans, lifting options, main conveyors and and so forth. For example: undervoltage of network leads to failure of protection devices, in emergency operation of work on the protected accession, as the voltage increases - to the unselective disconnecting as emergency operation out of the protected accession. Uncontrolled changes of the protected networks in the parameters lead to decrease to efficiency of the protection means.

Calculation of settings and characteristics of operation for the grid of enterprise is producing at

the moment of their planning, from the calculation of their maximal power. The most cases of operating electric chart, energy supplies of entered and developing enterprises again (the period of exit enterprise to full capacity could be reached for a few years) considerably differs from designed. While the map of setpoints remains unchanging, so becomes the main reason of unselective operation to protecting devices. Especially, it is characteristically for the enterprises of mining industry, particularly for coal and ore mines.

The repair modes, also modes of reserve feed from substations are different from power require the additional groups of setpoints operation, that remains without of attention and as the results of unselective actions at defensive devices.

In addition, considerable influence on efficiency of protecting exert capabilities and settings of protecting electrical network. Mainly in the expended case of sourcing electricity and electrical transmission line with equally spaced settings of demand specifications and time-varying parameters of defensive electrical network include in general the power source of electrical main with distributed constants capacity as usual induction motor and elements of devices, formation an integral part of protection.

he electrical main containing with high-voltage motor, mining, ventilation installation, excavating machine, facilities of mining and metals sector, crushing equipment and etc.

Theoretical analysis of operational conditions with isolated-neutral system is leading to non-selective operating devices of protection relay.

For the standard of «State all-union standard of 13109-97. Electrical energy».

«Electromagnetic compatibility of technical equipment. Quality standard of electric energy with system of power supply input» normally acceptable and overload capacity of steady-state voltage deviation of $\pm 5\%$ и $\pm 10\%$, through the time of

real mains voltage fluctuation higher than magnitude of (+ 20 %; - 30 %), especially in mineral resource industry [2].

In normally acceptable and maximum permissible with short defensive part of protection relay (to 2 km) some considerable changes of characteristics affected to feature selection and setting of protective relays.

For example the segment of transmission grid 6 kV (equivalent circuit is represented on figure 1) underground mine «Nurkazgan» form an integral part of corporation «Kazakhmys» short-circuit current calculation [3] has revealed the following:

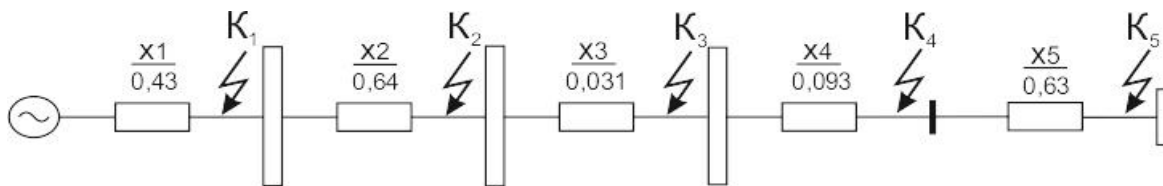

Figure 1. The equivalent circuit of part transmission grid 6 kV at underground mine «Nurkazgan» form an integral part of corporation «Kazakhmys»

The current value of three phase fault I_{shc} in point K_3 , when undervoltage three-phase short current circuit on 10 %, less than current value of three – phase short current circuit in point K_4 , in the design voltage of network.

When the operative current of defense I_{oc} maximal current cutoff (MCC) to possess in proportional reliances from three – phase short current circuit in the case of an error in point K_3 at the moment of under voltage three-phase short current circuit on 10 %, unselectively activates the protective device of lower-level part.

As the result of small difference summery inductance between the antecedent and fallows part in cable distribution network of mains voltage fluctuation at normal or overload capacity leads to unselective protecting operation.

The model development of electronic main with insulated neutral for the analysis of peculiarity and functioning mode of protecting electrical mode with

insulated neutral leading to protection devices to non-selective operation developed the relevant model.

The software envelope SimPowerSystems was elected on permanent assets of simulation, because of specialized instrument of electrical system [4]. On figure 2 is represented the model of electric network with isolated neutral on cranking voltage

6 kV. Developing the simulation model with insulated neutral allow to design working and emergency operation mode but otherwise testing parameters influenced to operation of protection device. Through the model is possible:

- in specific conditionals of exploitation validate the computing pickup setting of protection device.
- indicate the mode is leading to non selective actuating defensive devices.
- Analyze the behavior of devices in service-exposed components

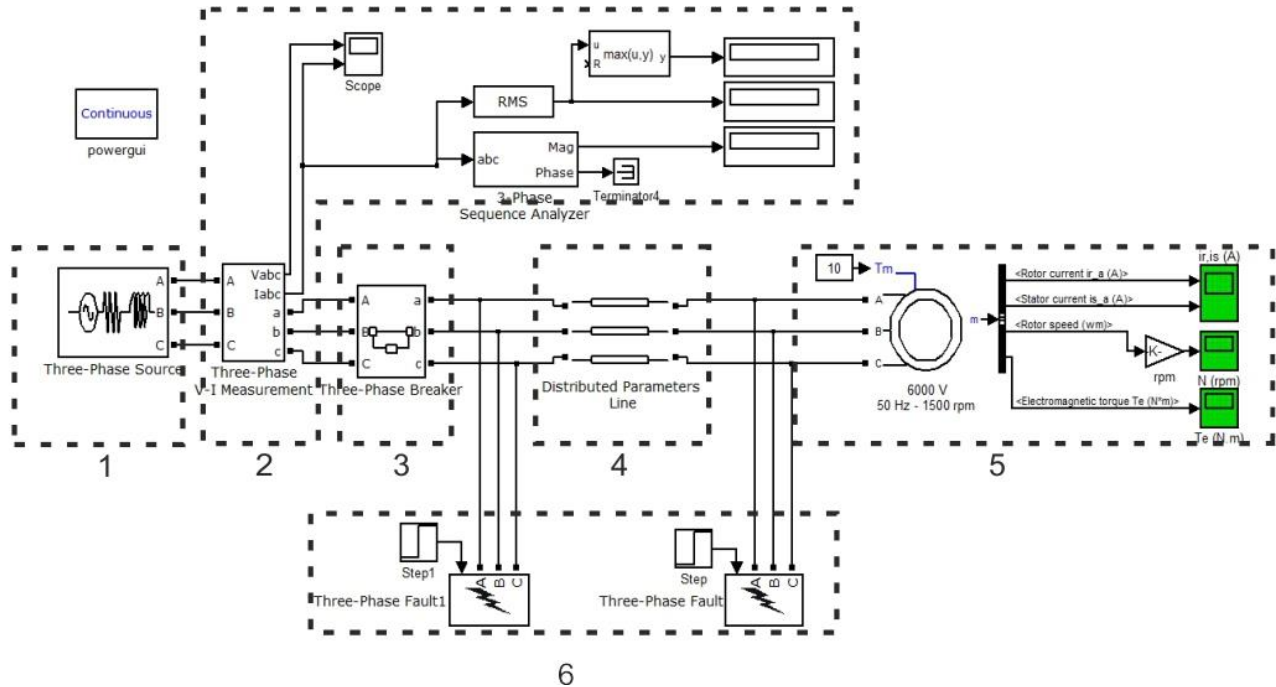

Figure 2. The model of electric system with isolated neutral: **1-** three-phase power $U = 6 \text{ kV}$, $f = 50 \text{ Hz}$, $P = 2500 \text{ kVA}$, $U_k = 5,5 \%$ (Three-PhaseSource); **2** –sensory package contains the measuring devices of phase sequence components current (Three - PhaseSequenceAnalyzer); The instrument of instantaneous current and electric line voltage network (Three-Phase V-I Measurement); current squared meter (RMS); The instrument of maximum magnitude inrush current and short-circuit current ($\max(u, y)$); **3** – High-voltage switchgear (Three-PhaseBreaker); **4** – The electric main characteristics of block calculated by programm Power_lineparam For wire grade AC 185 / 24 [5] In distance 1 km. (Distributed ParametersLine); **5** - induction motor which dimensional characters and adjust the status with characteristics of induction motor DAZO4 – 400HK - 4 [6]: $U = 6 \text{ kV}$; $f = 50 \text{ Hz}$; $P = 315 \text{ kVA}$; $\omega = 1405 \text{ rp/min}$ (Asynchronous machine) in accordance; **6-** Three phase devices close the phase against each other and on the ground set on the source and decline the triphase (Three-PhaseFault)

2. The model formulation of current protection device

The result is conduct with top-down analysis of operating and structure model digital devices of

current protection [7, 8, 9]. Developed the simulation model of current protection device figure 3. The model of current protection including current protection: maximal current cutoff (MCC), Overcurrent protection (OP), Protection of single

phase-to-ground fault (SPGF) protection, implement with interactive simulation tool SimPowerSystems (MATLAB/Simulink).

On the input model of a current device protection entered the meaning of phase current and zero sequence current (1 – Current). In transformative part (2 - TP) with block Zero-Order-Hold help was made the analogue-to-digital conversion signal originate from analog input 1. For the noise filtering and delay distortion is used low frequency filter Low-passFilter.

For receiving of symmetrical ampere serve the Fourier block. On the basis of blocks Three-PhaseSequenceAnalyzer Measure of zero currents sequence.

The logical section of analyzer protection (LP) implement with comparison element and trigger circuit Bistable, come out of skewing blocks On/Off Delay.

Short-circuit current magnitude of maximal current cutoff received, over current protection and zero-sequence current of single phase-to-ground fault protection.

Compare with presentable operation, originate from setpoint adjustment block operations. (3 - Threshold). The port of current protection devices distribute the loop actuating signal on switchgear (5 - TripSignal).

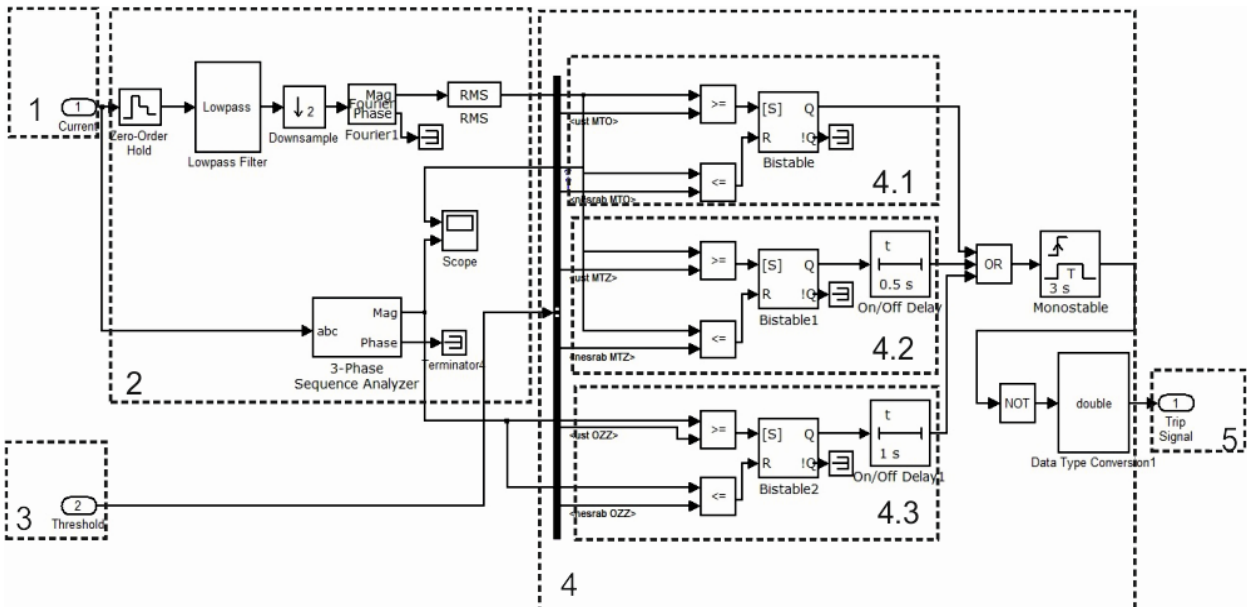

Figure 3. The simulation model of current protection devices: **1** – as analog input of three- phase alternating-current (Current); **2** – converting part (CP), **3** – pickup setting (block of Threshold); **4** – logical section (LS), 4.1- maximal current cutoff, 4.2 – Over current protection, 4.3 - single phase-to-ground fault protection ; **5** – switchgear

The simulation of emergency service controlled with constant parameters of network operation.

Next current parameters were calculated of three-phase fault at the end of stroke [3] $I_{sh.c.} = 3,473$

kA , nameplate amperage $I_{nom} = 31 A$, full-load amperage $I_{max} = 98 A$ (according to load parameters) for net model with insulated neutral,

designed electrical rating were checked by service simulating test.

For received network settings were designed the pickup setting [10] for maximal current cutoff (the first line of current protection) $I_{\text{actuation}} = 3820 \text{ A}$, $t_{\text{actuation}} = 0 \text{ sec}$, for over current protection (the second line of current protection) $I_{\text{actuation}} = 110 \text{ A}$, $t_{\text{actuation}} = 0.3 \text{ sec}$. For single phase-to-ground fault

protection, $I_{\text{actuation}} = 3,6 \text{ A}$, $t_{\text{actuation}} = 0.6 \text{ sec}$. In the process of modeling three-phase fault at the start of control network in fixed voltage network activated the (MTO) without standard fuse of time as to prevent damaging effect as result of over-current [11]. The oscillogram currents and voltages at the moment of working with short current circuit, represented on figure 4.

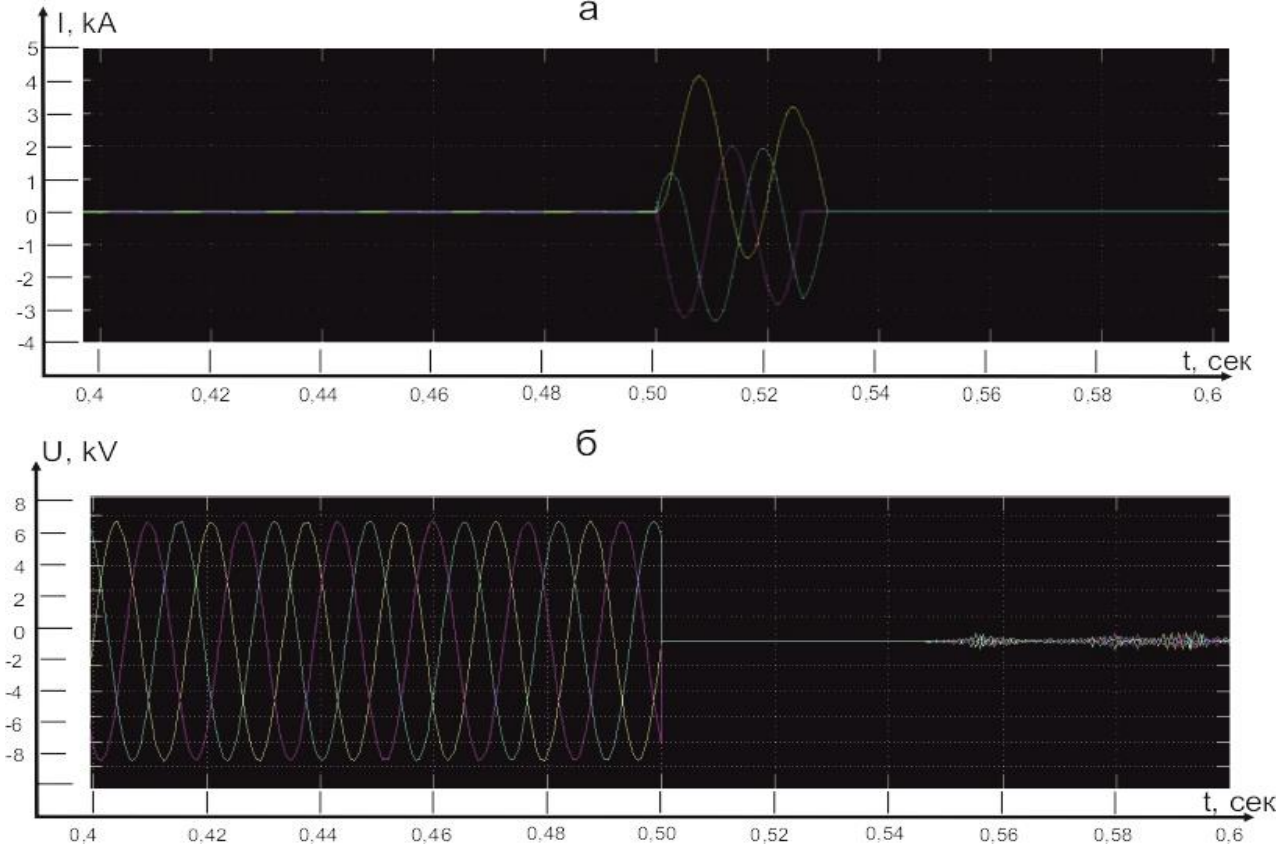

Figure 4. The oscillogram of currents (a), electric tiopotential (b) at the moment of three -phase fault on the oscillogram marked three main time line (figure 4 a, b).

a) from 0 sec. – to 0.5 sec typical operation network

b) from 0.5 sec. – to 0.53 sec operating emergency period from instant fault inception to overcurrent release of current protection devices with over-current characteristics and voltage slump network.

The actuation time of devices 0.03 sec, while pickup setting by time equal zero, due to activation of module ZeroOrderHold completing analog-signal sampling to contact-actuation time of switching apparatus model equals zero. For update micro

processing equipment in intrinsic time equal in limit of millisecond actuation time of switching system is from 40-50 millisecond [12], actuating time of switching system - 75 msec. [13, 14];

c) from 0.53 sec-to 0.6 sec after activate of switching device

In the case of double-phase fault at the end of protected line through the transition resistance 10 ohm in the fixed voltage activate the overcurrent protection with ime-delayed in 0,3 per second as

minimal back- up- time step of time settings over current protection, microprocessing of final terminal defense equal 0.3 per second [15]. The oscillogram of currents and voltages networks in double-phase fault can be seen in figure 5.

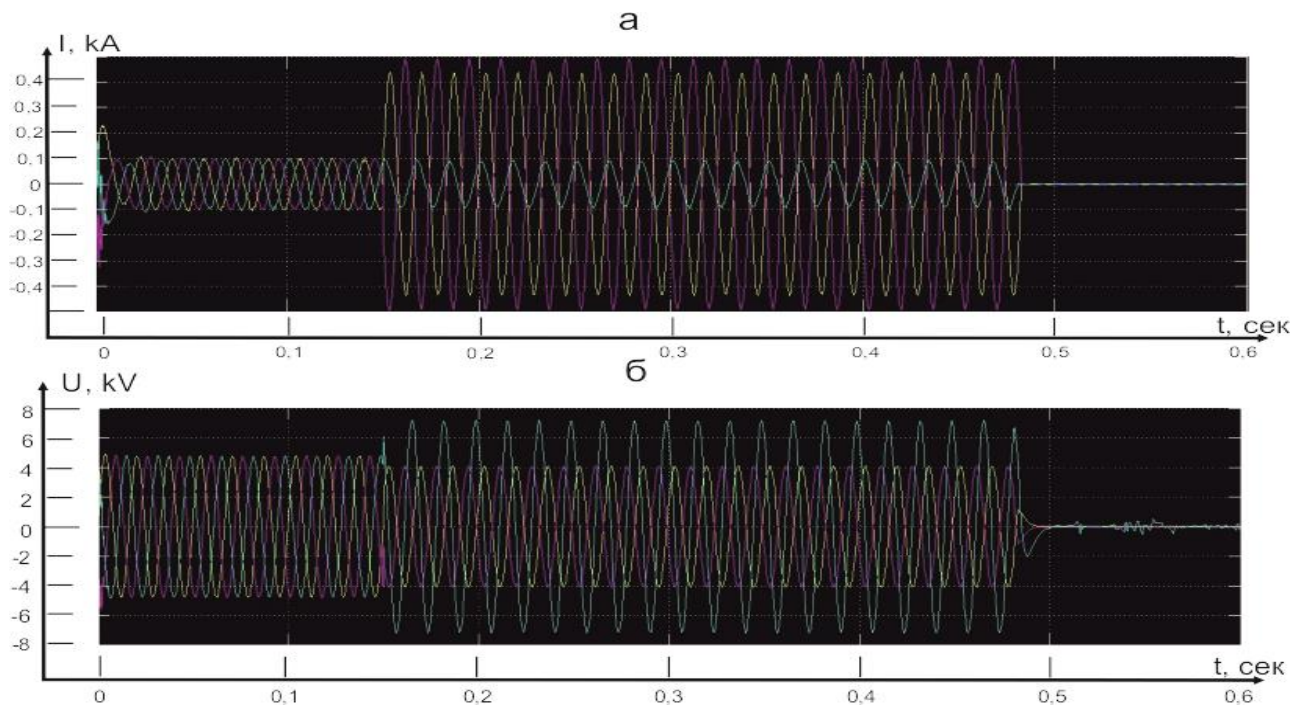

Figure 5. The oscillogram of currents (a), electric potential (b) at the moment of double-phase fault.

On the oscillogram represented picture 5 (a, b) it is possible to allocate three time segments:

a) from 0 sec – to 0.15 sec. typical operation network.

b) from 0.15 sec. – to 0.453 sec. operating emergency conditions from the period of instant beginning at double-phase fault through the activation of current protection device

c) from 0.453 sec –to 0.6 sec after activation of control and protective switching device.

When it's single phase-to-earth fault activate the single phase-to-ground fault protection with retard transmitter in 0.6 per second and the response delay trekking out of support reaction defense on steady-state ground short circuit [11].

The simulation result of emergency operation mode three phase fault, double ground fault, single phase-to-earth fault while fixed voltage is showed, that the model works correctly in this

conditionals and time characteristics relevant with a real-time basis work of safety current features. [8, 9, 12].

The model of emergency operation with multivariable control network.

The simulation experiment by modeling of power system emergency state connected with mains voltage fluctuations in the range from -10% to +10%.

The oscillogram of currents and voltages network when it's three phase fault at undertension network on - 10% represented on figure 6.

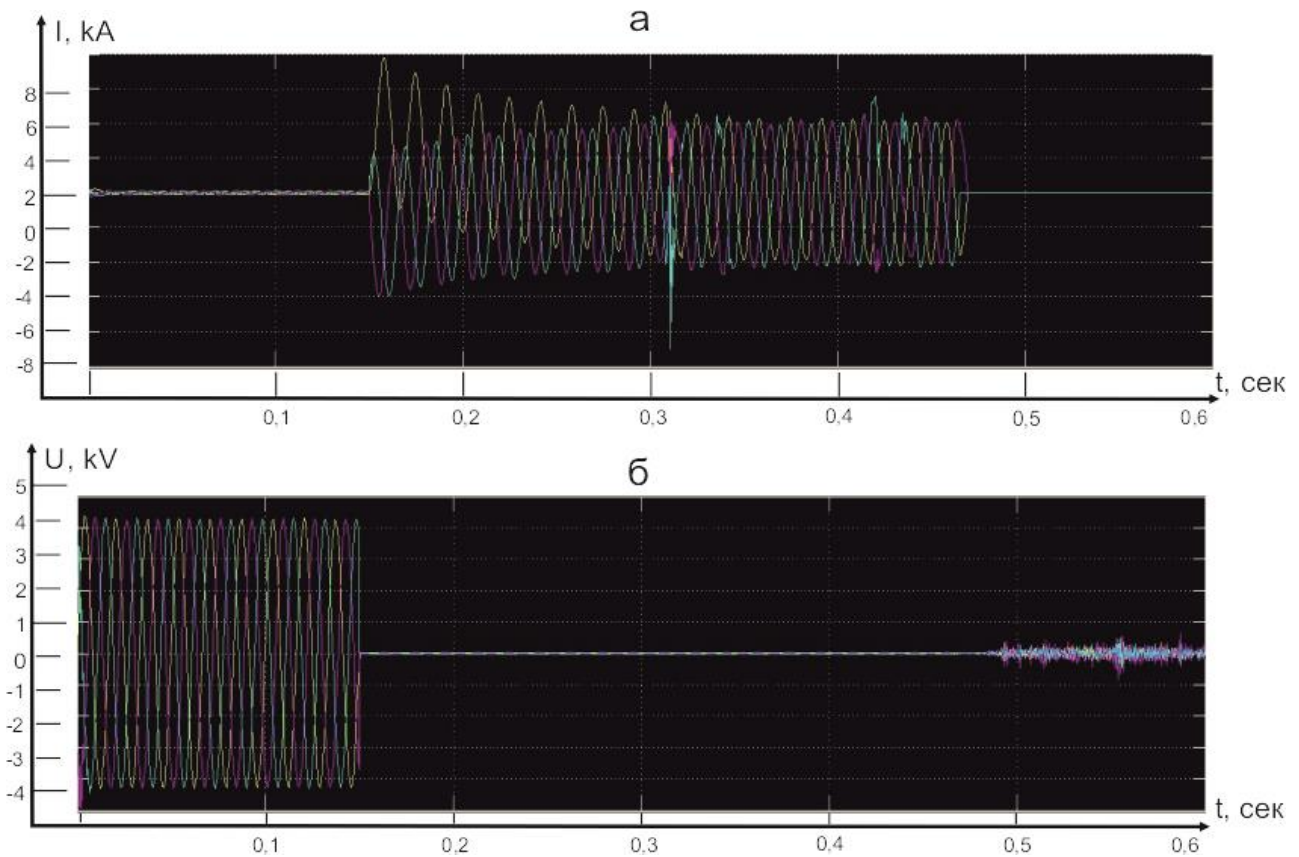

Figure 6. Oscillogram of current (a) in three phase fault (b) voltage depression of the network on 10 %

As reflected by oscillogram during of descend main voltage on 10 % ohm, current of three-phase short circuit lower than actuation setpoint engine transmission compartment, in consequence of which activate over current protection with time-delayed 0,3 per second becoming the second degree of current protection.

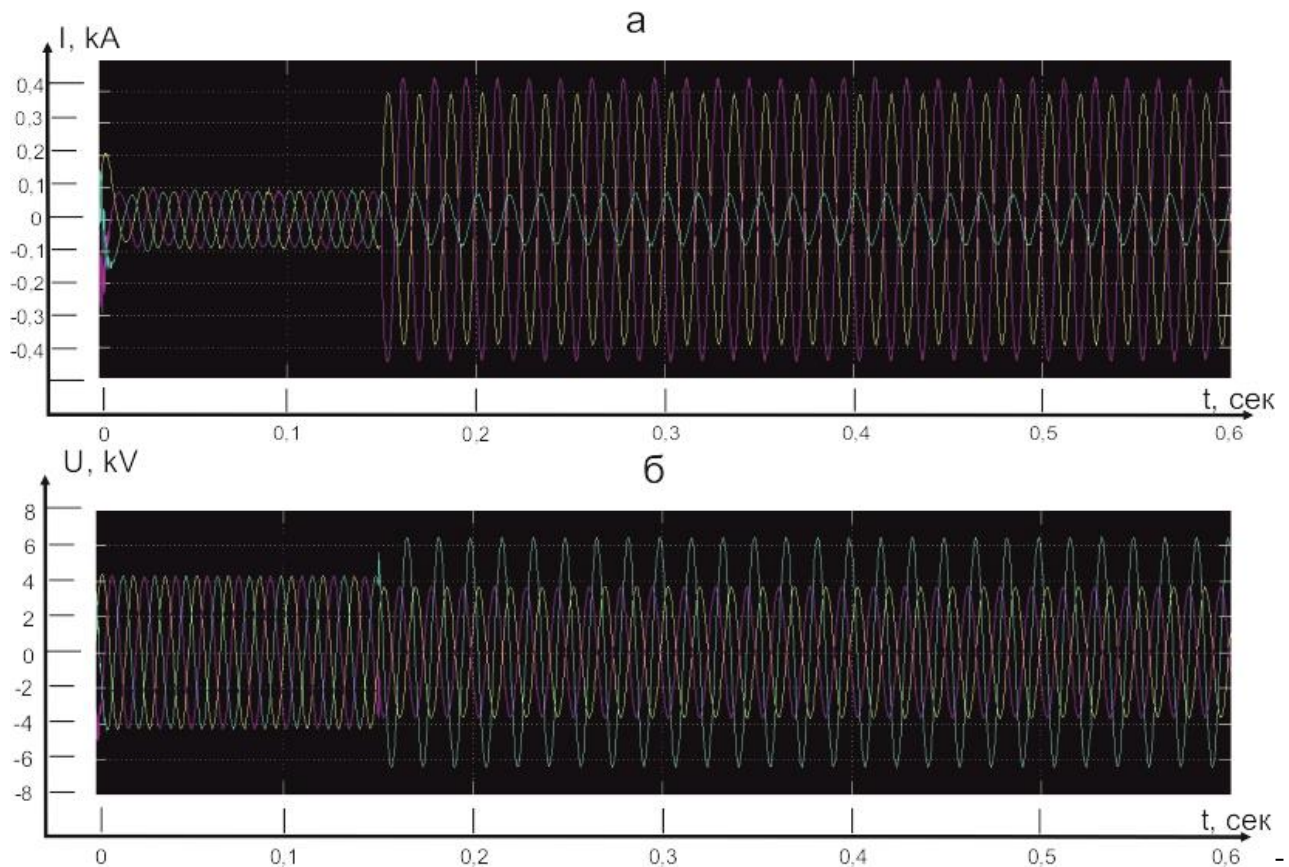

Figure 7. The oscillogram of current (a) and voltage of network (b) in the case of double phase closed –circuit fault through the transition resistance 10 ohm was represented.

According to the oscillogram current value of double phase closed-circuit fault through the transition resistance 10 Ohm. In the case of voltage network on -10% less than similar results of trigger settings of over current protection, that leads to failure of protection equipment to operate. In allocation networks and the result of this situation is operation of protecting devise in downstream connection and it isn't localized the damaging place, so leads to inadmissible overheating.

For the prevention of this simulations could be operable one more additional stage of over current protection with enormous delay, however, in the case of enormous time delay could be found damage of insulation conductors and completely failure of device.

The simulation results of single phase-to-earth fault In the case of voltage network on -10% less than similar results received by modeling of double phase ground fault through the increased contact resistance 10 Ohm due to main voltage, In the case of voltage network on -10% less than similar results.

The simulation results of three phase fault, double ground fault, single phase-to-earth fault.

In the case of voltage boosting on -10% higher, rated that operative current exceed of actuation set point. And this power distribution network could be cased to devise of protection reaction time cascade breaker with high actuation setpoint, which wean off the electric power supply of undemedging connectors.

Conclusions

1. Highly engineering designed experimental model of network with isolated neutral and universal model of current protection devices on the basis of this model performed the experiment connecting with various forms of defense. Accomplished of simulation experiment with rated operation voltage of network validate of design tester and developed the model by standard operating procedure.

2. Previous simulation experiment of protection reaction time, engine transmission compartment, over current protection and single phase-to-ground fault protection in the variable electrical line voltage on -10 % that correspond to real-time use metal mining industry.

The studies reserach found that voltage depression network by the emergency operative working (three phase fault, double ground fault, single phase-to-earth fault) deteriorate safety protection of submetering steps or protection devices of submetering attaching area, according to decrease of inverse time current relay.

In an emergency state automatic overvoltage protection boosting deteriorate the defense at a given instant to cascade breaker or protecting devices of superior attaching area, which conditioned with current increase activating higher than actuation setpoint.

3. The obtain results indicate with engineering design from adapting to varying duty works and operating factors of network protective gear.

References

1. Chernobrov N. In. Semenov V. A. relay protection of power systems: textbook for universities. - M.: Energoatomizdat, 1998.
2. V. I. Esterov, A. N. Mikitchenko. Current status and development trends of electric drives of mining machines for open-pit mining. The magazine "Drive and control". 2008, No. 2. P. 5-14(7).
3. Golubev M. L. Calculate short-circuit currents of 0.4-35 kV, second edition, revised and enlarged, Moscow: Energiya, 1980.

4. Chernykh I. V. "SimPowerSystems Modeling of electrical devices in MATLAB Simulink SimPowerSystems". Moscow: DMK Press, 2007.

5. <http://forca.ru/spravka/vl-i-provoda/harakteristiki-stalealyuminievyh-provodov-i-provodov-iz-alyuminievogo-splava-so-stalnym-serdechnikom.html>.

6. <http://el-dvigatel.ru/product/15014>

7. Shneerson E. M. Digital relay protection. – M.: Energoatomizdat, 2007.

8. Installation guide and application. Sepam 1000+ series 40 Functions protection of 3/1. MerlinGerin. SchneiderElectric.

9. The user's manual. Digital overcurrent protection with time delay and protection thermal overload with functions SIPROTEC 7SJ602 v AR.3.1. Siemens AG1999; 2001.

10. Fedoseev, A. M. Fedoseev, M. A. relay protection of electric power systems: Textbook. for universities - 2nd ed. Rev. and DOP. - Moscow: Energoatomizdat, 1992.

11. Rules of electrical devices. Approved by the Decree of the Government of the Republic of Kazakhstan of 24 October 2012 No. 1355. 13. Relay protection. 2. S. 604-695.

12. User manual (model R). MICOM P111. Universal relay overcurrent protection. Version 7B.

13. The vacuum circuit breakers of series BB/TEL ART 674 152.001 re. Manufacturer Tavrida Electric. Version 0704.

14. The user's manual. Automatic vacuum circuit-breaker 3AH51...54. Siemens. AG 2003 – 11 – 13 KB. eng. - eng.

15. Solov'ev A. L. guidelines for choosing the characteristics and settings of protection of electrical equipment with the use of microprocessor-based terminals SEPAM series produced by ShneiderElectric. First. - G. S. PBG, 2005.