

Licensed Shared Access evolution enables early access to 5G spectrum and novel use cases

S. Yrjölä^{1,*} and H. Kokkinen²

¹Nokia, Oulu, Finland

²Fairspectrum, Espoo, Finland

Abstract

This paper discusses the regulatory and standardization status of the Licensed Shared Access (LSA), compares it with the US Citizens Broadband Radio Service concept, and reviews results from the ongoing feasibility study in the European Telecommunications Standards Institute on temporary spectrum access for local high-quality wireless networks. Based on comparative analysis, a new LSA evolution concept and functional architecture is proposed, and the early results of the world first LSAevo validation are presented. Introduced system architecture can be applied to 3.4-3.8 GHz band so that fragmentation challenges to take the band into 5G use in the European member states can be solved, while ensuring that the communication of the incumbent users, fixed wireless access, fixed links, and satellite earth stations do not experience any harmful interference. In the end-to-end field trial, local high-quality wireless network use case for an industrial automation Micro-operator is validated.

Keywords: Citizens Broadband Radio Service, Cognitive Radio, Field trial, Industrial Automation, Licensed Shared Access, Micro-operator, Spectrum Sharing, 5G.

Received on 24 November 2017, accepted on 5 December 2017, published on 12 December 2017

Copyright © 2017 S. Yrjölä and H. Kokkinen, licensed to EAI. This is an open access article distributed under the terms of the Creative Commons Attribution licence (<http://creativecommons.org/licenses/by/3.0/>), which permits unlimited use, distribution and reproduction in any medium so long as the original work is properly cited.

doi: 10.4108/_____

1. Introduction

The rapid growth in the number of mobile and wireless communication systems' users with a large range of diverse services, applications and devices [1] will require significantly more spectrum and wider continuous bandwidth than currently available [2] despite advances in spectral efficiency and network densification. In order to meet additional spectrum demands, besides identifying more dedicated spectrum, the regulators have globally shown growing interest in novel regulatory approaches related to spectrum allocation, utilization, and management. The Radio Spectrum Policy Group (RSPG) of the European Commission (EC) have identified 700 MHz, 3.4-3.8 GHz and 26 GHz spectrum bands as pioneer bands for 5th Generation (5G) in Europe, recommend the band 3.4-3.8 GHz as the primary band for introduction of services in its

strategic roadmap [3], and call for industrial user experiments for the digitization of industry in its 5G Action Plan [4]. Furthermore, the Office of Communications (Ofcom) statement defines the same spectrum bands for the first wave of 5G in the UK [5]. Groupe Speciale Mobile Association (GSMA) recommends at least one frequency band allocated to 5G from each of the following frequency ranges: sub GHz, 1-6 GHz, and above 6 GHz [6]. The Global mobile Supplier Association (GSA) recommends 3.3-4.2 GHz frequency range, the Third Generation Partnership Project (3GPP) is working on in 5G New Radio (5G-NR) channel arrangement [7], as the primary band in the spectrum below 6 GHz, for the global introduction of 5G [8]. There is, on the other hand, a great variation of the current 3.4-4.2 GHz spectrum uses and authorization in the EU member states as well as globally. The Incumbents include, e.g., Fixed Wireless Access (FWA), satellite communications, and fixed links, with highly varying expire

*Corresponding author. Email: seppo.yrjola@nokia.com

dates of their radio licenses. Moreover, some of the member states plan to clear and auction at least parts of the band with nationwide licenses, while others have already prepared to have regional licenses on the band. There are member states, which plan on having primary and secondary 5G allocations with over 10 years and less than 2-year license periods, respectively.

From the above examples, it is apparent that Europe should prepare for a diverse 5G spectrum use on the primary 3.4-3.8 GHz band. The key objective of the European Telecoms framework is to provide a pro-investment framework to support 5G development through new bands, new users and usages, and increased more flexible use of spectrum. Proposed European Electronic Communications Code (EECC) framework promotes shared use of the spectrum [9].

Based on profound spectrum sharing work in policy, standardization and research, two novel licensing based sharing models have recently emerged, the Licensed Shared Access (LSA) [10] from Europe and the Citizens Broadband Radio Service (CBRS) from the US [11]. The two-tiered LSA builds on scale and harmonization in traditional exclusive licensing based regulation & standardization, and leverages existing asset and capability base of Mobile Network Operators (MNOs). The CBRS on the other hand, extends dynamics through an opportunistic third *License by the Rule* layer, fine-grained census tract based spectrum allocation, and sensing. Furthermore, the more dynamic CBRS concept was found likely to promote competition and foster innovation in the forms of new enabling technologies, novel ecosystem roles, and Internet era platform based business model designs [12]. The European Telecommunications Standards Institute Reconfigurable Radio Systems Technical Committee (ETSI RRS) initiated a feasibility study “*Temporary spectrum access for local high-quality wireless networks*” [13] in 2017 to study LSA evolution towards 5G spectrum, localization of spectrum for novel 5G use cases, and to enable horizontal sharing and sub-licensing for efficient use of the spectrum assets.

For these prominent spectrum sharing concepts currently under final stages of standardization and field validation, there is not much prior work available in the field of comparative architecture analysis and common evolutionary scenarios. In the Mobile and wireless communications Enablers for the Twenty-twenty Information Society-II (METIS II) project [14], spectrum sharing ecosystem evolution analysis was extended towards 5G, emphasizing potential changes in the roles, positions, and relationships of the key stakeholders in service delivery [14]. The Coordinated control and spectrum management for 5G heterogeneous radio access networks (Coherent) project [15], stemming from the METIS, proposes a novel three-plane architecture which utilizes the available network graphs for spectrum usage and consists of spectrum management plane (spectrum management application), infrastructure plane (or equivalently data plane), and a central coordination and control plane [15]. LSA evolution towards dynamic modes of operation utilizing dynamic channel configuration through sensing and dynamic

resource allocation algorithms was presented in [16]. The local high-quality wireless Micro-operator network concept was introduced in [17]. To the best of authors’ knowledge, the LSA evolutionary architecture concept and the related end-to-end (e2e) field trial validation has not been presented elsewhere. This paper seeks to answer the following research questions:

- (i) What are new requirements and amendments for the LSA spectrum sharing evolution to enable early access to 5G spectrum and local high-quality wireless Micro-operator networks?
- (ii) What are the needed revisions in architecture and technology?
- (iii) How could this be of help for key stakeholders and regulators in implementing LSA evolution?

This paper is an extension of work originally reported in proceedings of the 11th International Conference Cognitive Radio Oriented Wireless Networks and Communications, CROWNCOM’17 [18]. In this paper, earlier introduced Spectrum Broker concept and its resource configuration sub-processes: Spectrum supply, Spectrum demand and Transaction facilitation are complemented with underlying technical processes: *Spectrum resource matching*, *Spectrum resource activation*, and *Spectrum Monitoring* to form a complete spectrum management system. Furthermore, this research extends previous work [18] by presenting comparative system analysis of the CBRS and LSA spectrum sharing concepts, and by proposing originally CBRS based concepts and features into the LSA evolution. The novel LSAevo functional architecture, proposed in this paper, was originally validated by the authors in the EUCNC 2017 conference [19] with demonstration abstract only published. This paper completes the work through describing the functional architecture, validation set up, and reporting the performance measurement results.

The rest of the paper is organized as follows. First, the CBRS and the LSA sharing concepts are defined and their comparative analysis presented in section 2. Second, requirements for the LSA evolution are discussed, LSA evolution architecture concept proposed, and its validation presented. Finally, conclusions are drawn.

2. Comparative analysis of the spectrum sharing frameworks

This section will introduce the CBRS and the LSA spectrum sharing concept, and provide comparative analysis.

2.1. Citizens Broadband Radio Service (CBRS)

In the US, the President's Council of Advisors on Science and Technology (PCAST) report [20] suggested a dynamic spectrum sharing model as a new tool to the US wireless industry to meet the growing crisis in spectrum allocation,

utilization and management in 2012. The key policy messages of the document were further strengthened in 2013 with Presidential Memorandum [21] stating “We must make available even more spectrum and create new avenues for wireless innovation. One means of doing so is by allowing and encouraging shared access to spectrum that is currently allocated exclusively for Federal use. Where technically and economically feasible, sharing can and should be used to enhance efficiency among all users and expedite commercial access to additional spectrum bands, subject to adequate interference protection for Federal users.”

In Figure 1, the US three-tier authorization framework with the Federal Communications Commission's (FCC) spectrum access models for 3550-3650MHz and 3650-3700MHz spectrum segments are illustrated. While the general CBRS framework could be applied to any spectrum and between any systems, the current regulatory efforts in the FCC are focused on the 3550-3700 MHz band [22].

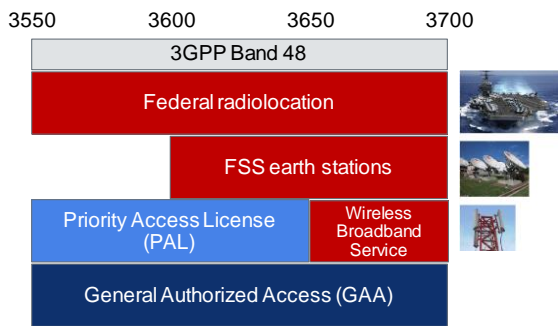

Figure 1. The US 3-tiered CBRS spectrum access model and band plan.

The standardization process for the CBRS is ongoing in the Wireless Innovation Forum (WinnForum) [23], and for the specific spectrum band in the 3GPP [24]. The three tiers depicted in Figure 1 are:

1) *Incumbent Access (IA)* layer consists of the existing primary operations including authorized federal users and Fixed Service Satellite (FSS) earth stations. The IA is protected from harmful interference from the CBRS users by geographic exclusion zones and interference management conducted by the dynamic Spectrum Access System (SAS),

2) *Priority Access (PA)* layer includes critical access users like hospitals, utilities, governmental users, and non-critical users, e.g., MNOs. PA users receive short-term priority authorization (currently, a three-year authorization is considered) to operate within designated geographic census tract with Priority Access Licenses (PALs) in 10 MHz unpaired channel. PALs will be awarded with competitive bidding, and with ability to aggregate multiple consecutive PALs and census tracts to obtain multi-year rights and to cover larger areas. Any entity eligible to hold a FCC license could apply for a PAL and is protected from harmful interference from the General Authorized Access layer.

3) *General Authorized Access (GAA)* layer users, e.g., residential, business, and others, including Internet service providers (ISPs) are entitled to use the spectrum on opportunistic *license-by-rule* regulatory basis without interference protection. In addition to the defined 50% floor of GAA spectrum availability specified to ensure nationwide GAA access availability, GAA could access unused PA frequencies. GAA channels are dynamically assigned to users by an SAS. The addition of the third tier is intended to maximize spectrum utilization, and to extend usage from centralized managed Base Stations (BSs) to stand-alone GAA access points, Citizens Broadband radio Service Devices (CBSDs).

The SAS dynamically determines and assigns PAL channels and GAA frequencies at a given geographic location, controls the interference environment, and enforces exclusion zones to protect higher priority users as well as takes care of registration, authentication, and identification of user information [25]. In 2016, the FCC finalized rules for CBRS [22] and introduced the *light-touch* leasing process to make the spectrum use rights held by PALs available in secondary markets. Under the light-touch leasing rules, PA Licensees are free to lease any portion of their spectrum or license outside of their *PAL protection area (PPA)* without the need for the FCC oversight required for partitioning and disaggregation. This allows lessees of PALs to provide targeted services to geographic areas or quantities of spectrum without additional administrative burden. Coupled with the minimum availability of 80 MHz GAA spectrum in each license area, these rules will provide the increased flexibility to serve specific or targeted markets. Furthermore, the FCC will let market forces determine the role of an SAS, and as such, stand-alone exchanges or SAS-managed exchanges are permitted.

The CBRS devices (CBSDs) are fixed or portable base stations or access points, or networks of such, and can only operate under the authority and management of a centralized SAS, which could be multiple as shown in Figure 2.

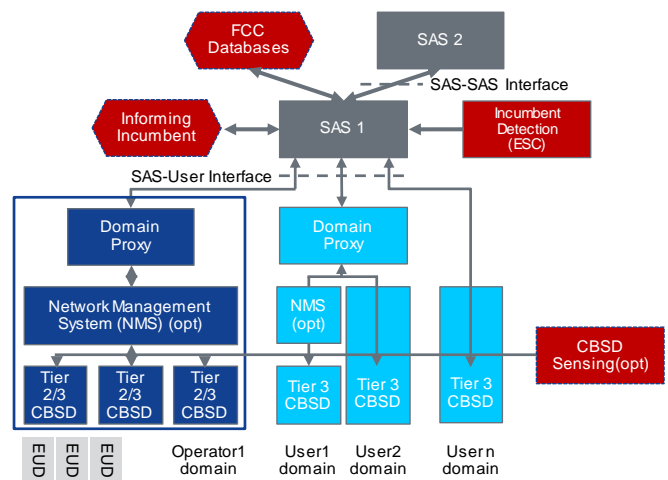

Figure 2. The US 3-tiered CBRS concept and functional architecture.

Both the PA and the GAA users are obligated to use only the FCC certified CBSDs, which must register with an SAS with information required by the rules, e.g., operator identifier, device identification and parameters, and location information. In a typical MNO deployment scenario, the CBSD is a managed network comprising of the *Domain Proxy* (DP) and Network Management System (NMS) functionality. The DP may be a bidirectional information routing engine or a more intelligent mediation function enabling flexible self-control and interference optimizations in such a network. In addition to larger MNO-operated Mobile Broadband (MBB) networks, a DP enables combining, e.g., the small cells of a shopping mall or sports venue to a virtual BS entity that covers the complete venue. The DP can also provide a translational capability to interface legacy radio equipment in the 3650–3700 MHz band with an SAS to ensure compliance with the FCC rules. A MNO could utilize a DP and/or an operator-specific SAS in protecting commercially sensitive details of their network deployment data.

In the dialog between industries [11], the FCC and the main incumbent user, United States Department of Defence (DoD), it is assumed that in addition to informing database approach, there is a need to introduce a Non-Informing Approach, requiring *Environmental Sensing Capability* (ESC). The ESC architecture and implementation scenarios discussed include a dedicated sensing network for an SAS, collaborative sensing by commercial network BSs, or their combination. According to the FCC rules [22], the SAS must either confirm suspension of the CBSD's operation or its relocation within 300 seconds after the ESC detection communication, or other type of notification from the current federal user of the spectrum band.

The White House aims to expand wireless innovation in spectrum sharing further through identifying an additional 2 GHz of federal owned spectrum below 6 GHz for future commercial sharing [26]. The success of the CBRS is critical to future federal–commercial spectrum sharing. Moreover, the FCC has already proposed the use of the three-tier model and the SAS for 5G in several cmWave and mmWave bands.

The CBRS system has been validated in field trials in Finland and US. Architecture, implementation and field trial results are presented, e.g., in [27] and [28].

2.2. Licensed Shared Access (LSA)

The EC communication based on an industry initiative promoted spectrum sharing across wireless industry and diverse types of Incumbents [29]. In 2013, the RSPG of the EC defined LSA as [30] “a regulatory approach aiming to facilitate the introduction of radio communication systems operated by a limited number of Licensees under an individual licensing regime in a frequency band already assigned or expected to be assigned to one or more incumbent users. Under the LSA framework, the additional users are allowed to use the spectrum (or part of the spectrum) in accordance with sharing rules included in their

rights of use of spectrum, thereby allowing all the authorized users, including Incumbents, to provide a certain Quality of Service (QoS).”

The recent development in policy, standardization and architecture has focused on applying the LSA to leverage scale and harmonization of the 3GPP ecosystem. This would enable MBB systems to gain shared access to additional harmonized spectrum assets not currently available on exclusive basis, particular the 3GPP band 40 (2.3-2.4 GHz) as defined by the European Conference of Postal and Telecommunications Administrations (CEPT) [31]. ETSI introduced related system reference, requirements, and architecture documents [32]-[34] from the standardization perspective. In the LSA concept, the incumbent spectrum user, such as a Program Making and Special Events (PMSE) video link, a telemetry system, or a fixed link operator, is able to share the spectrum assigned to it with one or several LSA Licensee users according to a negotiated *Sharing Framework* (SF) and *Sharing Agreement* (SA). The LSA License (LL) model guarantees protection from harmful interference with predictable QoS for both the Incumbent and the LSA Licensee.

The LSA architecture consists of two new elements to protect the rights of the Incumbent, and for managing dynamics of the LSA spectrum availability shown in Figure 3: the *LSA Repository* (LR) and the *LSA Controller* (LC). The LR supports the entry and storage of the information about the availability, protection requirements, and usage of spectrum together with operating terms and rules. The LC located in the LSA Licensee's domain grants permissions within the mobile network to access the spectrum based on the spectrum resource availability information from the LR. The LC interacts with the Licensee's mobile network to support the mapping of *LSA Resource Availability Information* (LSRAI) into appropriate radio transmitter configurations via Operation, Administration and Management (OAM) tools, and to receive the respective confirmations from the network.

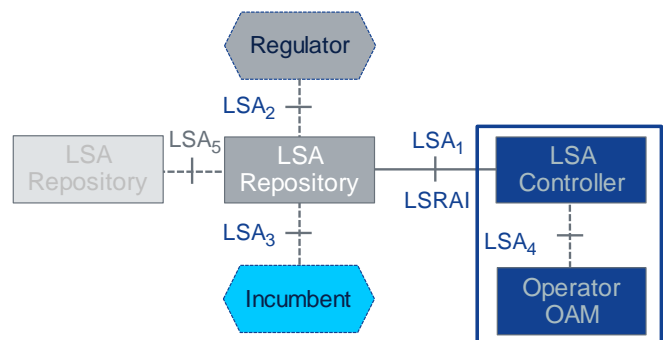

Figure 3. The LSA architecture reference model.

The LSA system for the 2.3-2.4 GHz band has been validated in field trials in Finland, Italy and France. Architecture, implementation and field trial results are presented, e.g., in [35]-[38]. The second use case currently

being considered in European regulation is the application of LSA to the 3.6-3.8 GHz band [39]. For this band, the incumbent usage is less dynamic, and the LSA band availability is guaranteed in the license area for a known period. This allows extension to more innovative use cases, such as local private networks using small cells, as there is no need for additional frequency resource or existing infrastructure to support dynamic handover.

2.3. Comparative analysis of LSA and CBRS

In this section, the CBRS and the LSA spectrum sharing concepts are summarized and compared. Comparative analysis of architecture, interface, functions, protection, and security is summarized in Table 1.

The state diagrams for the CBRS and the LSA are depicted in Figures 4 and 5, respectively. The key difference is that the LSA doesn't allow dynamic *Spectrum Grant* and *Relinquishment* for local usage. In the CBRS, the Grant is the authorization provided by an SAS to a CBSD, subject to a Heartbeat exchange, to transmit using specified operating parameters. Grants are identified by a unique Grant identifier. Once issued, a Grant's operating parameters are never changed; if new or modified operating parameters are required, then a new Grant must be obtained. The Grant's operating parameters are maximum Effective Isotropic Radiated Power (EIRP) and Channel. If the CBSD no longer needs access to the Grant prior to its expiration, the CBSD initiates the Grant Relinquishment procedure. A Grant can be in different states as depicted in the CBSD Grant State Diagram.

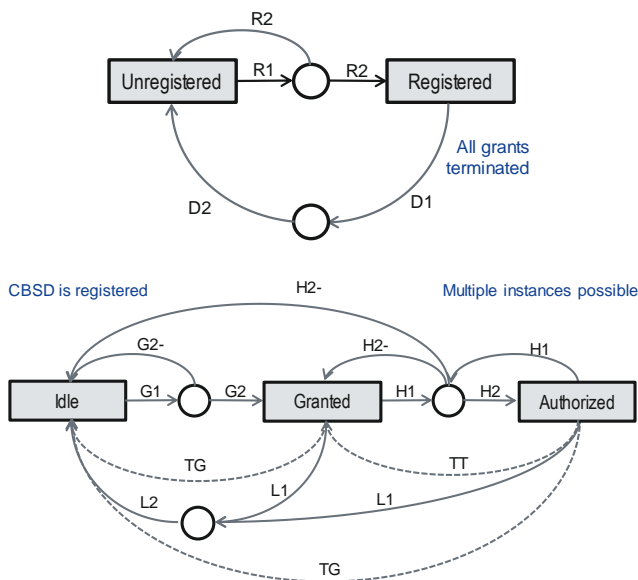

Figure 4. State diagrams for the CBRS Registration/Deregistration and Grant state.

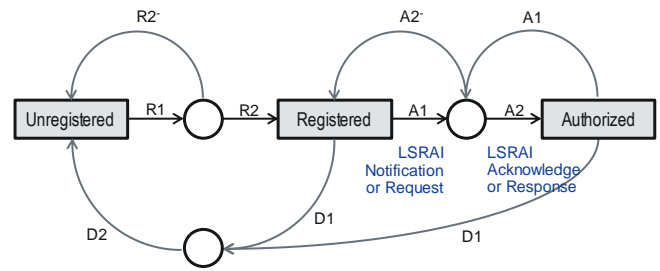

Figure 5. State diagram for the LSA.

3. LSA evolution

3.1. High level requirements

High level requirements for this LSA evolution concept study and validation were derived from the ongoing feasibility study in the ETSI RRS technical committee on temporary spectrum access for local high-quality wireless networks [13], and the research on Micro-operator concept [17] and [40]. Additional evolution use cases under study includes: nomadic events, use under test licenses, and governmental use, e.g., local non-critical military use.

Micro-operator concept and Factory of the Future use case

The Micro-operator concept was recently introduced for local service delivery in 5G to establish local small cell networks, and to offer context related services and content with guaranteed quality [17]. Deployment of local specialized networks requires changes to the current operational models and regulations to allow new agile players to deploy the Radio Access Networks (RANs) and deliver new services. Micro-operator use cases include deployments of ultra-dense specialized small cell RANs in distinct locations such as factories, campuses, malls, and sports arenas. With the help of network slicing and spectrum sharing techniques, the Micro-operator can rapidly respond to local needs and provide high connectivity services [40]. A network slice can be tailored to support specific applications and services delivered over Micro-operator's network where the RAN part of the slice is from the Micro-operator and other parts can be from the owner of other physical network infrastructure.

A fundamental rethinking of the mobile network operations and management principles is needed to address novel requirements for diverse locations, services, use cases, and business models. The ability to identify and capture network resources and capabilities at a targeted geographical area can be combined with the ability to enable usage at the needed service level for the use case. The Micro-operator ecosystem enables any party that would need telco grade wireless networking capacity in selected locations to build their own network solution or take it as-a-Service (aaS).

Table 1. Comparative analysis of the LSA and the CBRS spectrum sharing concepts.

	CBRS	LSA
Architecture	<ul style="list-style-type: none"> • SAS, DP, CBSD • Spectrum management decision entity in SAS supporting dynamic features • Spectrum management implementation entity as part of SAS (decision of CBSD operating parameters) • Flexible assignment of Controller function to domains: DP provides parts of the Controller function; other functions are part of SAS. • Multiple radio access support covered by CBRS on Incumbent side and CBSD side 	<ul style="list-style-type: none"> • LR, LC, Mobile/Fixed Communications Network (MFCN) • Spectrum management decision entity in LR • Spectrum management implementation entity as part of LC and/or 3GPP OAM functionality. Enables use of efficient protection zone. • Flexible assignment of LC function to domains: In LSA phase 1 a fixed assignment to the LSA Licensee domain. • Multiple radio access support covered by LSA on Incumbent side and Licensee side: the LSA phase 1 foresees LTE as Licensee RAT.
Interfaces	<ul style="list-style-type: none"> • Defined enabling standardized interoperability. • SAS-SAS, SAS-CBSD • No direct access of Incumbents, ESC is used to detect Incumbent usage of spectrum. Informing Incumbent as an option. • NRA access via SAS interface (SAS admin proprietary) • Spectrum user access via SAS-CBSD interface; DP proxy may handle multiple CBSDs 	<ul style="list-style-type: none"> • General level requirements and frameworks only to date • LSA5, LSA1 • LSA3 covers Incumbent spectrum availability control, input of Sharing Agreement, and Reporting information • NRA access via named LSA2 interface (Proprietary as not defined in the standards) • Spectrum user access via LC using LSA1 (LC-LR interface) and optional LSA4 (OAM, LC-MFCN)
Function	<ul style="list-style-type: none"> • 3-tier sharing • Public, competitive suppliers of access control available to any user • Sharing Framework, PA License, GAA Registration at SAS • Sub-licensing of spectrum resources supported by the PPA concept allowing PAL users 	<ul style="list-style-type: none"> • 2-tier sharing • Direct relationship between Incumbent and Licensee • Sharing Framework, Sharing Agreement and LSA License • Sub-licensing of spectrum resources currently not supported
Protection and exclusivity	<ul style="list-style-type: none"> • SAS introduces licensed like PAL spectrum resources and license exempt like “License by the Rule” GAA spectrum resources without guaranteed QoS. • Incumbent protection via rules by FCC; the protection is performed by SAS and translated in spectrum availability information, which is provided to the requesting PA or GAA user • Spectrum resource is shared between Incumbent, PA, and GAA users following the sharing rules of FCC, SAS may use additional rules to influence the spectrum resource assignment to a user to guarantee fairness. Multiple SAS operators in the same area allows CBSD operator to switch SAS operator • Finer granularity in geographic and temporal sharing condition, and broader scope of licenses enable enterprise/residential/small MNO deployments and third tier • SAS service is an advantage to unexperienced non-MNO operators 	<ul style="list-style-type: none"> • LSA follows a licensing concept and provides QoS when spectrum is available for Licensees. • Incumbent protection via Sharing Framework and Sharing Agreement; both results in protection requirements, which are provided to the LSA Licensee • Spectrum resource is exclusive shared between Incumbent and a LSA Licensee; different LSA Licensees are protected by guards, which needs to be derived via the Sharing Framework and Sharing Agreement • Large blocks of nation-wide geographic long-term exclusivity favor wide-area MNOs
Security	<ul style="list-style-type: none"> • Comsec and Opsec 	<ul style="list-style-type: none"> • Comsec and Opsec

Micro-operator concept can introduce a new control point in the digital value platform through the spectrum and network slice management in technology utilizing Self Organizing Network (SON), in Management and Orchestration (MANO), policy (brokerage) and business (aaS).

There will be numerous deployment scenarios. The Micro-operator can install and manage itself a local wireless network and roaming contracts with MNO. Network infrastructure can be owned by the Micro-operator or enterprise/vertical. Alternatively, in the Infrastructure as a Service (IaaS) model, a Micro-operator offers multi-tenant infrastructure service with value added localized resource optimization to larger MNOs. A MNO provides applications, and manages and optimizes the service with components either instantiated in the Micro-operator edge cloud, or in the MNOs cloud. In the Platform-as-a-Service (PaaS) or SW-as-a-Service (SaaS) model the Micro-operator will operate and offer a hosted aaS functions or complete service components to MNOs. A MNO will manage e2e service leveraging Micro-operator's function and services optimized and scaled for local dynamics in demand, resources and network status.

In the *Factory of the Future (FoF)* scenario, new business models can be built, e.g., around process-aaS, robot/machine-aaS, maintenance-aaS, or virtual network-aaS. Service vertical integration of networked factory allows for an optimized and more dynamic usage of resources, and calls linkage of manufacturing processes performed by multiple systems and providers inside the factory boundaries. This set stringent requirements for Service Level Agreement (SLA) processes, workflow integration, standardized interfaces, and networked services for security, trust and data analytics. Fundamentally, the aim of the FoF communication is to monitor and control real-world actions, and conditions of the specific physical equipment. Industrial automation has a wide range of use cases with a unique set of communication requirements, particularly latency, reliability, availability, and throughput. These high-quality networks are typically geographically confined in area, serve heterogeneous professional applications requiring high predictable levels of service guarantee, and may require own network control and operation functions due to specific security standards and privacy requirements [41].

Temporary spectrum access for local high-quality wireless networks

ETSI RRS feasibility study on temporary spectrum access for local high-quality wireless networks [13], focus on spectrum sharing approaches offering new entrants (Licensees) spectrum access rights, so that they are able to provide predictable levels of QoS to the end users on a local geographical area on short or longer-term basis. These spectrum access rights are described in the form of a Sharing Agreement that constitute the regulatory legal basis for ensuring a certain QoS level for all authorized users, including Incumbents. Use cases prefer a private network deployment or hybrid with public network infrastructure and management, to implement needed security standards and

privacy requirements. Initially, the LSA and the tier 2 of the CBRS sharing concepts are considered for the following scenarios:

Local high-quality wireless networks as private network areas scenario focus on vertical industries integration, and foresees the set-up and operation of private networks in a local and closed environment without the necessary direct involvement of a MNO. The Licensee may be, for instance MNO, Mobile Virtual Network Operator (MVNO), or a new vertical service provider entering the market owning access infrastructure and providing spectrum management services.

Local high-quality wireless networks as in-standard service areas scenario considers an integration of local high-quality wireless networks into the MFCN ecosystem where the role of the Licensee is occupied by a MNO.

3.2. LSAevo concept and functional architecture

Based on the comparative analysis in Section 2.3. and requirements discussed in section 3.1., the following considerations and issues with current spectrum sharing concepts were found.

In general, the geographic scope of licenses should serve the needs of micro-targeted deployments as well as larger deployments, while guaranteeing the QoS of spectrum resources that may be impacted by dynamic spectrum sharing. Concept should enable neutral operator instances. The management of the spectrum resource at local level by the vertical should be guaranteed in case spectrum resource is provided by a MNO. Furthermore, security of sensitive network information of verticals should be guaranteed, e.g., SAS administrators should protect CBSD registration information.

LSA authorization process with regulator and Incumbent is complex, lengthy, and vary from country to country. Incumbent interface is difficult to standardize generally, and possible only for a specific country and specific Incumbent type. Furthermore, the interface between regulator and LR/Spectrum Manager (SM) has been proprietary, exception being the Ofcom harmonized TV White Spaces (TVWS) in UK. Deployment durations are ranging from several hours to several years. LSA doesn't support of flexible Grant and Relinquishment procedures for LSA spectrum resource, neither support mutual renting. CBRS has interface for SM – Licensee/CBSD, while LSA1 interface is an internal in SM.

In the CBRS concept, GAA users have no interference protection. CBRS PAL License auction prefers MNOs and may lead to expensive PPA claims. Increasing the term for PALs with greater certainty will promote investment, and larger geographic scope of PAL will facilitate deployment.

Proposed LSAevo functional architecture

Proposed LSAevo functional architecture in Figure 6, builds on proven LSA benefits of leveraging scale and harmonization in regulation & standardization, and utilization of existing commercial assets and capabilities.

Introduced new extensions to LSA architecture depicted in Figure 3, enable new frequency bands towards 5G, localization of spectrum with novel 5G use cases, e.g., for verticals, horizontal sharing & sub-licensing for efficient use of the spectrum assets, and as a recapitulation lowers entry barrier for new service providers through unbundling investments in spectrum, infrastructure and services. Identified initial features for the LSA evolution are:

- 2-tier sharing with deterministic and predictable channel arrangement to avoid complexity and to satisfy the stringent QoS requirements.
- Central management for spectrum and license handling. CEPT has created generic technical requirements for co-existence of different radio systems that should be used as reference for SM protection.
- SM broker as additional operator type beside vertical and MNO (as SAS operator for CBRS)
- Hierarchical coexistence/interference management with possibility to negotiate and perform local adaptations at network and service level.
- Facilitates local network infrastructure, shared network infrastructure, e.g., MVNO, MNO or hybrid service.
- Re-use of the CBRS concept in modified SAS registration procedure for GAA to simplify LSA Licensing process.
- Extend the LSA1 interface to support spectrum resource Grant and Relinquishment (as shown in the CBRS state diagram in Figure 4) for a MFCN without violating sharing method specific rules.
- Utilize CBRS PPA in CBSD-SAS interface information exchange instead of CBSD detailed data.

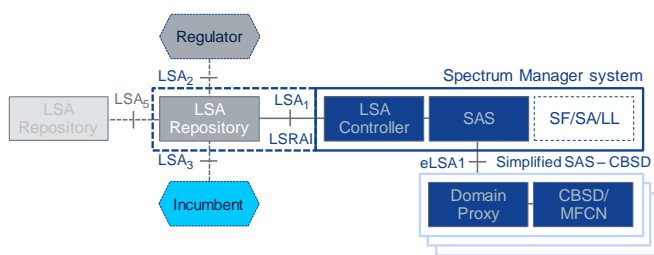

Figure 6. The LSAevo architecture reference model based on the LSA standards with CBRS extensions.

3.3. LSAevo validation

In this trial, we responded to the discussed early 5G deployment requests by demonstrating how LSA evolution can move towards more dynamic and flexible spectrum management concept. LSAevo concept and system architecture can be applied to 3.4-3.8 GHz band so that current individual fragmentation challenges to take the band into 5G use in the respective member states can be solved, while ensuring that the communication of the Incumbent users, FWA, fixed links, and satellite earth stations do not

experience any harmful interference. In the e2e field trial, an industrial automation FoF Micro-operator use case was validated. In this use case, the objects, special needs (low latency), and other solutions are local, e.g., industrial machinery never leaves the site or they need special connectivity only when in the local defined area. This leads to a different type of network, opportunities, and requirements. Private Micro-operator networks offer relatively speaking unlimited capacity and speed by tapping into large pools of local spectrum. Network architecture is built around distributed and edge clouds offering low latency and local content management to boost use case development with the domain specific ecosystem as illustrated in Figure 7.

Validation platform, depicted in Figures 7 and 8, utilizes open Application Programming Interface (APIs), native-cloud architecture, and leverages the sharing economy principles to create a sustainable business models across stakeholders and interfaces. The demonstrated Network-as-a-Service (NaaS) deployment consists of commercial Long Term Evolution (LTE) User Equipment (UEs), 3.5 GHz eNodeBs (eNBs) under LSAevo control, and virtualized hosted Evolved Packet Core (EPC). The implemented SM demo system runs on commercially available virtualized NMS and SON platforms, and is built on synergies between the existing LSA and CBRS standards. The LTE test network is installed in the Nokia factory in Oulu, Finland. The Incumbents were created for the demonstration purpose based on typical types and protection criteria in Finland and the EU member states [19].

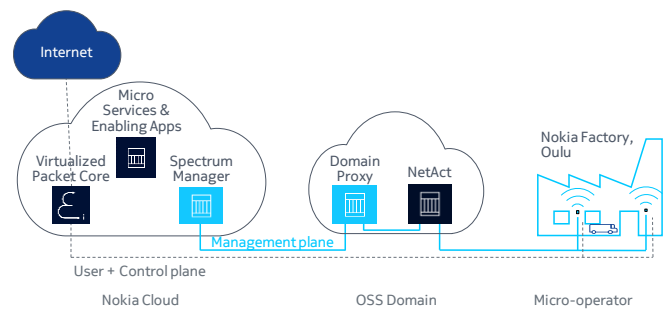

Figure 7. The LSAevo trial environment.

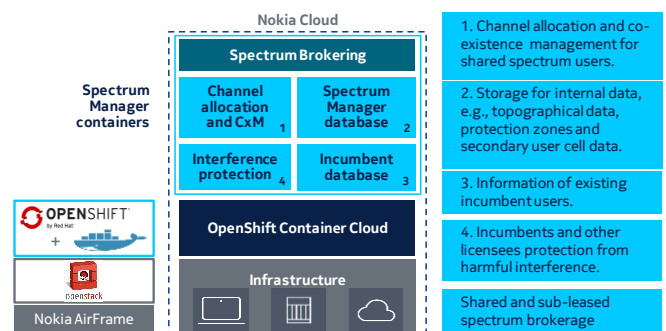

Figure 8. The LSAevo Spectrum Manager architecture.

The LSAevo Spectrum Manager (SM) was implemented in Nokia Cloud service running the network as an on-demand private network. The hardware infrastructure is based on Nokia AirFrame running RedHat’s openStack and OpenShift Docker-formatted containers. As container images include code, system libraries, and settings, containers isolate software from the processing infrastructure. The SM had two main functions resembling the LSA Repository and LSA Controller. *Interference Protection* ensures that the LSAevo controlled NaaS LTE network does not cause harmful interference to Incumbent spectrum users. It could be considered as an electronic, automated version of radio regulation. *Channel Allocation and Co-existence Management (CxM)* optimize the radio resource utilization of the NaaS LTE network within the limits defined by the Interference Protection. The data processed by the Interference Protection and Channel Allocation and CxM were stored in *SM and Incumbent databases*, respectively. The spectrum management system contained also *Spectrum Brokering* [18] to facilitate sub-leasing of radio licenses from a license holder to a temporary and regional spectrum user. The Spectrum Broker was not demonstrated in this trial. The Incumbent information was provided by the Finnish Communication Regulatory Authority (Ficora). The largest number of Incumbents were the FWA spectrum allocations registered in Radio communication sector of the International Telecommunication Union (ITU-R) database. ITU-R database contained a few FSS earth stations, which were considered and protected by LSAevo. R&D radio licenses and microwave links for broadcasting applications in Oulu area were the geographically closest Incumbents.

Results of the initial e2e field trial demonstrated first time at the EUCNC 2017 [19] and WInnComm-Europe 2017 [42] are summarized in Table 2. The LSAevo band evacuation and reconfiguration process was implemented into Nokia e2e trial environment and initial performance measurement studies have been conducted to evaluate the involved time scales for the e2e network evacuation and reconfiguration in the LSA band due to Incumbent’s immediate LSA spectrum notification. Timestamps have been recorded at SM (Docker), DP (Nokia Eden-NET SON platform) and UE (Nemo Outdoor). In addition, OAM (Nokia NetAct Configuration Manager Operation Manager) logs were used. DP is registered and authorized to SM. Heartbeat interval (HB) was 10 seconds.



Figure 9. The LSAevo Spectrum Manager performance measurement set up.

Table 2. LSAevo band reconfiguration measurement results.

Cumulative time for workflow step T1-T8 in seconds	e2e
T1 Incumbent notification arrives at SM	0
T2 SM informs DP to vacate the spectrum	8
T3 DP sends relinquishment message for frequency in use. DP EMS configuration for freq. vacation starts	9
T4 UE LTE cell service dropped (Nemo Outdoor)	69
T5 EMS ends, DP asks new frequency grant from SM	81
T6 After HB, EMS configuration of new granted freq. begin	91
T7 UE LTE cell service received	154
T8 SM is informed EMS config. ready by DP via HB that	163

4. Conclusions

This paper discusses the regulatory and standardization status of the Licensed Shared Access, compares it with the Citizens Broadband Radio Service concept, reviews results from the ongoing feasibility study in the European Telecommunications Standards Institute on temporary spectrum access for local high-quality wireless networks, proposes a new LSA evolution architecture, and presents the early results of the world first LSAevo e2e validation. In the trial, we responded to the early European 5G deployment requests by demonstrating how LSA evolution can move towards more dynamic and flexible spectrum management concept enabling integration of local vertical services. Introduced LSAevo concept and system architecture can be applied to 3.4-3.8 GHz band so that fragmentation challenges to take the band into 5G use in the member states can be solved, while ensuring that the communication of the incumbent users, fixed wireless access, fixed links, and satellite earth stations do not experience harmful interference.

In the e2e field trial, local high-quality wireless network use case for an industrial automation Micro-operator on 3.4-3.8 GHz band was validated. Network architecture was built around distributed and edge clouds, offering low latency and local content management to boost use case development with the domain specific ecosystem. Proposed LSAevo builds on proven LSA benefits of leveraging scale and harmonization in regulation & standardization, and utilization of existing commercial assets and capabilities. Enhanced flexibility and dynamics in sharing stems from the CBRS framework. Introduced new extensions enable, new frequency bands towards 5G, locally-confined and temporarily-flexible spectrum with novel 5G use cases, horizontal sharing and sub-licensing for efficient use of the spectrum assets, and as a recapitulation lowers entry barrier for new service providers through unbundling investments in spectrum, infrastructure, and services. Performance validation was conducted by measuring the duration of the spectrum evacuation and the base station cell reconfiguration workflow steps in the LSA band due to Incumbent’s immediate LSA spectrum resource availability

notification. The measurement results revealed that both the emergency evacuation and the reconfigure operation can be done in a way that fulfils typical service Incumbent's requirements in the Finnish sharing use case, and wider in a static and semi-static LSA use cases.

This study provides viewpoints about additional ingredients and revisions, which can be of help for key stakeholders and regulators for implementing LSA evolution. The successful deployment of the LSA evolution towards 5G needs will further improve the efficiency of the spectrum use, influence the management approach of other spectrum bands and create new business opportunities. This calls for a collaborative effort from the government, industry and academia to set the harmonized regulatory framework, agree on the standard, and prove the architecture and technology enablers in a pre-commercial trial with e2e ecosystem including novel Incumbents and use cases, like private networks and Micro-operators.

Acknowledgements.

This work has been done in the Micro-operator concept for boosting local service delivery in 5G (uO5G) research project within the 5G programs of the Tekes, Finnish Funding Agency for Technology and Innovation.

References

- [1] Cisco white paper (2016) *Visual Networking Index: Global Mobile Data Traffic Forecast Update, 2015-2020*.
- [2] ITU Report M.2290-0 (2014) *Future spectrum requirements estimate for terrestrial IMT*.
- [3] RSPG16-032 (2016) *Final Radio Spectrum Policy Group strategic roadmap towards 5G for Europe. Opinion on spectrum related aspects for next-generation wireless systems*.
- [4] EC COM(2016) 588 final Communication from the Commission to the European Parliament, the Council, the European Economic and Social Committee and the Committee of the Regions (2016) *5G for Europe: An Action Plan*, Brussels.
- [5] Ofcom Statement (2017) *Update on 5G spectrum in the UK*.
- [6] GSMA Spectrum (2016) *5G Spectrum Public Policy Position*.
- [7] 3GPP RP-170855 (2017) *Work Item on New Radio (NR) Access Technology*.
- [8] GSA (2017) *The Future of IMT in the 3300-4200 MHz frequency range*.
- [9] European Commission, COM(2016) 590, Articles 2 (26), 45 (2) (e), 46 and 47 (2016) *Proposal for a Directive of the European Parliament and of the Council establishing the European Electronic Communications Code*.
- [10] ECC Report 205 (2014) *Licensed Shared Access*.
- [11] FCC, Docket 12-354, 14-49 (2014) *Amendment of the Commission's Rules with Regard to Commercial Operations in the 3550-3650 MHz Band*.
- [12] Yrjölä, S., Ahokangas, P. and Matinmikko, M. (2015) Evaluation of recent spectrum sharing concepts from business model scalability point of view. In *Proceedings of IEEE International Symposium on Dynamic Spectrum Access Networks*, 241-250.
- [13] ETSI RRS, DTR/RRS-0148 (2017) *Feasibility study on temporary spectrum access for local high-quality wireless networks*, Early draft 0.0.6.
- [14] METIS II D1.1 (2016) *Refined scenarios and requirements, consolidated use cases, and qualitative techno-economic feasibility assessment, Mobile and wireless communications Enablers for the Twenty-twenty Information Society-II*. [Online] Available: https://metis-ii.5g-ppp.eu/wp-content/uploads/METIS-II_D1.1_v1.0.pdf.
- [15] COHERENT Deliverable D4.1 (2015) *Report on enhanced LSA, intra-operator spectrum-sharing and micro-area spectrum sharing, Coordinated control and spectrum management for 5G heterogeneous radio access networks*. [Online]. Available: http://www.ict-coherent.eu/coherent/wp-content/uploads/2015/10/COHERENT_D4_1_v1.pdf.
- [16] Frascolla, V. et al. (2016) Dynamic Licensed Shared Access - A New Architecture and Spectrum Allocation Techniques. In *Proceedings of IEEE 84th VTC*, Montreal, OC, 1-5.
- [17] Matinmikko, M., Latva-aho, M., Ahokangas, P., Yrjölä, S. and Koivumäki, T. (2017) Micro operators to boost local service delivery in 5G. *Wireless Personal Communications journal*, Springer.
- [18] Kokkinen, T., Kokkinen, H., and Yrjölä, S. (2017) Spectrum broker service for Micro-operator and CBRS Priority Access Licenses. In *Proceedings of the 11th International Conference Cognitive Radio Oriented Wireless Networks and Communications (CROWNCOM)*, Lisbon, Portugal, Sept. 2017.
- [19] Yrjölä, S. and Kokkinen, H. (2017) E2e field trial of the Dynamic Spectrum Manager for a 5G industrial automation micro operator on 3.4-3.8 GHz in Europe. In 2017 European Conference on Networks and Communications: Radio Access Technologies towards 5G (RAT), Oulu, Finland.
- [20] The White House (2012) *Realizing the Full Potential of Government-Held Spectrum to Spur Economic Growth*. President's Council of Advisors on Science and Technology (PCAST) Report.
- [21] The White House (2013) *Expanding America's Leadership in Wireless Innovation, Presidential Memorandum*.
- [22] FCC 16-55 (2016) *The Second Report and Order and Order on Reconsideration finalizes rules for innovative Citizens Broadband Radio Service in the 3.5 GHz Band*.
- [23] WINNF Spectrum Sharing Committee (2016) *SAS Functional Architecture*. [Online]. Available from: <http://groups.winnforum.org/d/do/8512>.
- [24] The 3GPP, R4-168006 (2016) *Relevant requirements for Band 48 introduction in 36.104*, TSG-RAN4 Meeting #80bis, Ljubljana, Slovenia.
- [25] Sohul, M., Yao, M., Yang, T. and Reed, J. (2015) Spectrum Access System for the Citizen Broadband Radio Service. *IEEE Commun. Mag.* 53(7): 18-25.
- [26] The Federal Communications Commission Technical Advisory Council Advanced Sharing and Enabling Wireless Technologies (EWT) WG (2014) *Sharing recommendations* [Online] Available: <https://transition.fcc.gov/bureaus/oet/tac/tacdocs/meeting92314/TACMeetingSummary9-23-14.pdf>.
- [27] Aho, P. et al. (2016) Field Trial of Citizens Broadband Radio Service (CBRS). In *Proceedings of the 22nd European Wireless Conference (EW16)*, Oulu, Finland.
- [28] Hamblen, M. (2016) *Multiple U.S. trials underway for shared 3.5 GHz wireless spectrum*, Computerworld, Inc. [Online]. Available: <http://www.computerworld.com/article/3075748/mobile-wireless/multiple-u-s-trials-underway-for-shared-3-5ghz-wireless-spectrum.html>.

- [29] EC COM (2012) 478 (2012) *Promoting the shared use of radio spectrum resources in the internal market*, European Commission.
- [30] RSPG (2013) *Opinion on Licensed Shared Access*. RSPG13-538, Radio Spectrum Policy Group.
- [31] CEPT, ECC Decision (14)02 (2014) *Harmonized technical and regulatory conditions for the use of the band 2300-2400 MHz for Mobile/Fixed Communications Networks (MFCN)*.
- [32] ETSI TR 103.113 (2013) *Mobile Broadband services in the 2300-2400 MHz frequency band under Licensed Shared Access regime*.
- [33] ETSI TS 103 154 (2014) *System requirements for operation of Mobile Broadband Systems in the 2300 MHz -2400 MHz band under LSA*.
- [34] ETSI TS 103 235 (2015) *System Architecture and High-Level Procedures for operation of Licensed Shared Access (LSA) in the 2300 MHz-2400 MHz band*.
- [35] Matinmikko, M. et al. (2013) Cognitive radio trial environment: First live authorized shared access-based spectrum-sharing demonstration. *IEEE Veh. Technol. Mag.* 8(3):30-37.
- [36] Yrjölä, S. et al. (2015) Licensed Shared Access (LSA) Field Trial Using LTE Network and Self Organized Network LSA Controller. In *Proceedings of Wireless Innovation Forum European Conference on Communication technologies and Software Defined Radio (WInnComm-Europe)*, 68-77.
- [37] ECC PT1(16)028 (2016) *World's first LSA pilot in the 2.3-2.4 GHz band*. Input contribution to ECC PT1 #51.
- [38] RED Technologies (2016) *Ericsson, RED Technologies and Qualcomm Inc. conduct the first Licensed Shared Access (LSA) pilot in France*, [Online]. Available from: <http://www.redtechnologies.fr/news/ericsson-red-technologies-and-qualcomm-inc-conduct-first-licensed-shared-access-lsa-pilot-france>.
- [39] ECC PT1(16)82 Annex 20 (2016) *Operational guidelines for spectrum sharing to support the implementation of the current ECC framework in the 3 600-3 800 MHz*.
- [40] Kibria, M., Villardi, G., Nguyen, K., Liao, W., Ishizu, K. and Kojima, F. (2017) Shared Spectrum Access Communications: A Neutral Host Micro Operator Approach. *IEEE Journal on Selected Areas in Communications*. PP(99), May 2017.
- [41] Ashraf, S. A., Aktas, I., Eriksson, E., Helmersson, K. W. and Ansari, J. (2016) Ultra-Reliable and Low-Latency Communication for Wireless Factory Automation: From LTE to 5G. In *Proceedings of IEEE conference on Emerging Technologies and Factory Automation*, Berlin, Germany, Sept. 2016.
- [42] Yrjölä, S. and Kokkinen, H. (2017) Citizen's Broadband Radio Service enables Micro-operators to provide Industrial automation. In *Wireless Innovation Forum European Conference 2017*, Oulu, Finland, 2017.