

MiXiM – The Physical Layer An Architecture Overview

Karl Wessel, Michael Swigulski, Andreas Köpke, Daniel Willkomm
Technische Universität Berlin, Telecommunication Networks Group
Berlin, Germany
{wessel, swigulski, koepke, willkomm} @tkn.tu-berlin.de

ABSTRACT

Simulating the physical layer of wireless communication remains a challenge. Communication standards like OFDM or MIMO systems go beyond the simple single narrow frequency band, single antenna model used in popular simulators. Yet, these technologies gain popularity, since they provide researchers with a plethora of possibilities that can be explored to invent new protocols or improve existing ones. However, building a detailed and sufficiently accurate model for such complex systems is a tremendous task that takes a lot of time. In this paper we present the physical layer model of MiXiM, which tackles this task. It provides the researcher with an easy to use interface to the wireless transmission medium. It models the wireless medium in all three dimensions (time, space and frequency) supporting the implementation of future wireless communication standards, but at the same time also supports easy modeling and simulation of traditional single frequency systems.

1. INTRODUCTION

MiXiM [1] has been introduced [3] as a very powerful extension to simulate wireless and mobile networks using the discrete event simulator OMNeT++ [4]. MiXiM aims to provide the developer with a powerful and feature-rich toolbox to enable and facilitate the simulation and performance analysis of wireless networks. At the same time the structure and design of MiXiM is such, that it tries to hide the complexity of such simulations and provides the developer with a clean and easy to use interface. This approach facilitates the development and implementation of specific models and protocols for wireless communication without having to worry about the underlying architecture more than necessary.

In order to gain a deeper understanding of the complexity of the problem, let us start with the main components that are responsible for the transmission process, shown in Figure 1. In this figure, we consider the transmission of a single packet, concentrating on the interaction of the components. Assume, the sending Medium Access Control (MAC) protocol received a packet that shall be transmitted. After packing this into a Service Data Unit (SDU), the MAC protocol hands this packet down to the physical layer for transmission, together with some information on how the packet

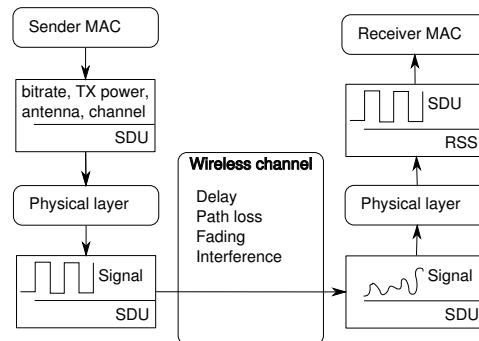

Figure 1: Aspects of a wireless transmission

shall be transmitted. The physical layer uses this information to compute a signal that represents the packet. This signal is transmitted via the wireless medium, where it gets distorted by multiple influences, starting from attenuation due to various causes as well as other interfering transmitters. The physical layer of the receiver receives this distorted signal and has to derive a binary representation that hopefully resembles the original SDU. This is passed to the receiving MAC layer, together with some meta information like the received signal strength indicator (RSSI) of the packet.

In this paper we present the physical layer of MiXiM. While many popular simulators only model single frequency, single antenna systems, such models are not sufficient anymore. The physical layer of MiXiM is designed with flexibility in mind without sacrificing efficiency. It can be used for simple single frequency, single bit rate systems used for instance in sensor network simulations, multiple channels, multiple bit rate systems like IEEE 802.11b that sends the header and the payload of the packet with different bit rates, systems that change the transmission frequency between each packet like Bluetooth, Orthogonal Frequency Division Multiplexing (OFDM) systems like 802.11a that transmit in parallel on multiple frequencies and Multiple Input Multiple Output (MIMO) systems that use multiple antennas for the transmission and the reception.

In addition to this wide range of different transmission standards, there are many different models for the wireless channel, each concentrating on a different effect in a certain environment. There are path loss models that attenuate the transmitted signals according to the traveled distance, abstract models for shadowing effects due to obstacles like the log-normal fading, models for fast fading due to the mobility of the nodes like Rice and Rayleigh fading and many more.

To complicate things further, standards like 802.11g include a Forward Error Correction (FEC) and the design of the physical

Permission to make digital or hard copies of all or part of this work for personal or classroom use is granted without fee provided that copies are not made or distributed for profit or commercial advantage and that copies bear this notice and the full citation on the first page. To copy otherwise, to republish, to post on servers or to redistribute to lists, requires prior specific permission and/or a fee.

OMNeT++ 2009, Rome, Italy.

Copyright 2009 ICST, ISBN 978-963-9799-45-5.

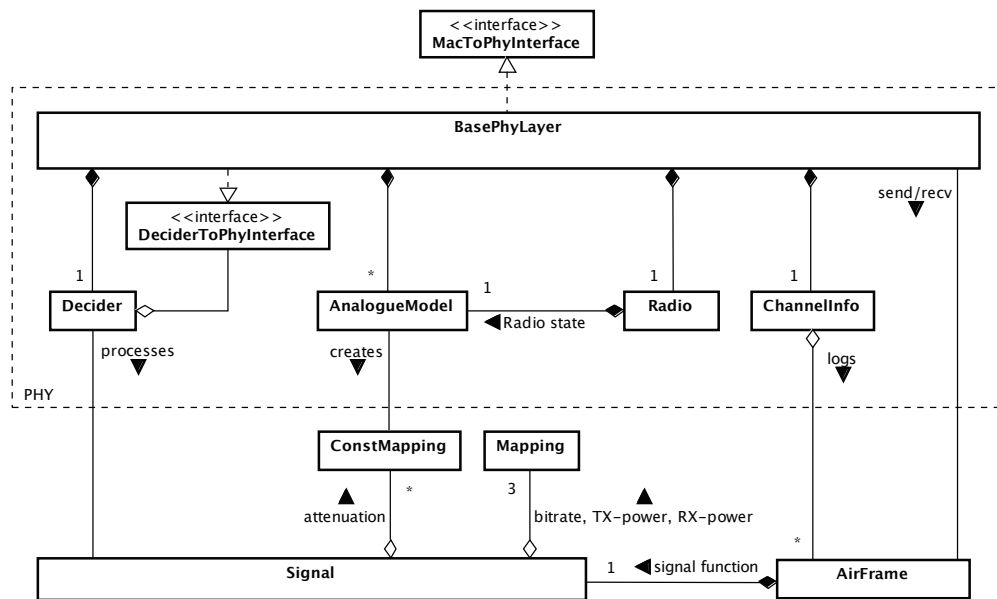

Figure 2: physical layer class-graph

layer of MiXiM should not prevent research on the influence of such codes. This means that all the attenuation effects should be computable on a sub-packet time scale.

In this paper, we present how the physical layer supports all these aspects of a wireless transmission. Section 2 gives an overview of the physical layer structure in MiXiM and explains how the various aspects shown in Figure 1 are allocated to objects in the BasePhyLayer. In Section 3 we explain the AnalogueModels and the Radio module. The Decider functionality is detailed in Section 4. In Section 5 we explain the mapping implementation used to express and combine multi-dimensional signals. We conclude in Section 6.

2. PHYSICAL LAYER OVERVIEW

The physical layer module is one of the core modules in MiXiM. It is responsible for message sending and receiving, collision detection, and bit error calculation. Additionally, it is responsible for applying the AnalogueModels used in the simulation.

Figure 2 shows a detailed class-graph of the physical layer in MiXiM. The MiXiM physical layer (dashed box in Figure 2) is divided into five parts: The AnalogueModels are responsible for simulating the attenuation (like shadowing, fading and path loss) of a received signal. The Radio module simulates the physical characteristics of the radio, like switching times and simplex / duplex capabilities. Details on the AnalogueModels and the Radio module can be found in Section 3. The ChannelInfo module keeps tracks of all AirFrames that are currently on the channel and is detailed in Section 2.2. The Decider is responsible for evaluation (classification as noise or signal) and demodulation (bit error calculation) of the received messages. Additionally, it provides channel sensing information to the MAC layer. Details on the Decider can be found in Section 4.

Finally, the BasePhyLayer is the “umbrella” module responsible for the interaction of the different parts of the physical layer. Additionally, it provides the interfaces to the MAC layer and the physical layers of other nodes. Details on the BasePhyLayer are described in Section 2.1. To provide a clear interface and to avoid

memory overhead the BasePhyLayer is the only OMNeT++ module. All other modules of the physical layer are designed as pure C++ classes instead of separate OMNeT++ modules.

2.1 BasePhyLayer

The BasePhyLayer provides the general structure for a physical layer module in MiXiM.

The AnalogueModels and Decider modules to be used by a BasePhyLayer are defined in a config.xml file which contains the names of them as well as the needed parameters. For AnalogueModel and Decider implementations already included in MiXiM this is sufficient, own implementations have to be introduced by sub-classing BasePhyLayer and proper initialization in the overloaded getDeciderFromName()- or getAnalogueModelFromName()-method. A new Radio module can be plugged into the physical layer by sub-classing BasePhyLayer and overloading the initializeRadio()-method to properly initialize the new Radio module.

One of the main tasks of the BasePhyLayer is the processing of messages (AirFrames). Whereas the sending of messages is straight forward and only requires the BasePhyLayer to set some parameters and calculate the propagation delay (if necessary), the receiving process is more complicated. Figure 3 shows a state diagram of the receive process. Note, that sending an AirFrame in MiXiM means that it is received by all nodes which potentially are in the interference range of the sending node. It is the nodes’ task to figure out which AirFrames are (a) strong enough to be received and (b) are actually destined for the node. For details, refer to [3].

When the reception of the AirFrame starts (i.e. the first bit arrives), it is first of all registered with ChannelInfo, which keeps track of all AirFrames on the channel (see Section 2.2 for details). After that all AnalogueModels are applied to the Signal contained in the AirFrame (see Section 3). The AirFrame is then handed over to the Decider, which reschedules the AirFrame to the time it will make a decision whether to receive and further process the AirFrame or to treat it as noise. For details on the decision process refer to Section 4.1.

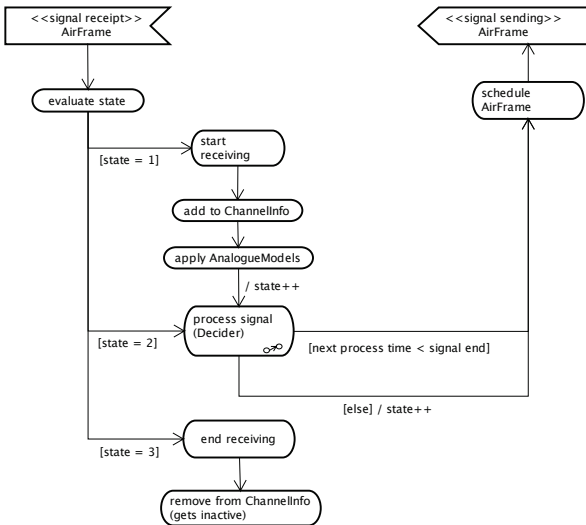

Figure 3: Receiving an AirFrame

2.2 ChannelInfo

The `ChannelInfo` module is used to keep track of the `AirFrame`s on the channel. As soon as an `AirFrame` starts (i.e. the first bit arrives), it is added to `ChannelInfo` and considered *active* until it ends. Once ended, it becomes *inactive* for `ChannelInfo` but is still kept as interfering `AirFrame` until there is no more *active* `AirFrame` intersecting with it in time. The `AirFrame`s have to be kept in order to be able to calculate the signal to interference plus noise ratio (SINR) of a specific `AirFrame` currently being received (for which all other `AirFrame`s on the channel are interference). `ChannelInfo` is able to return all `AirFrame`s currently on the channel intersecting with a given, not outdated, time-interval. This service is used by the `Decider` to calculate SINR values.

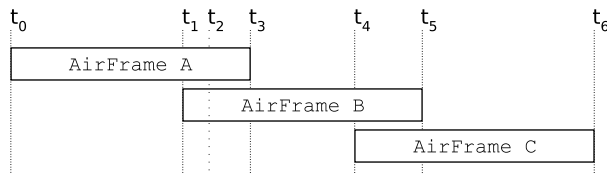

Figure 4: AirFrames on the channel

Consider the simple scenario in Figure 4 where the `AirFrame`s A, B and C arrive one after another. They are handled by `ChannelInfo` as follows:

- t_0 : A starts and becomes *active*.
- t_1 : B starts and becomes *active*.
- t_3 : A ends and becomes *inactive* but is not yet deleted since it intersects with B, which is still *active*.
- t_4 : C starts and becomes *active*.
- t_5 : B ends and becomes *inactive* but is not yet deleted since it intersects with C, which is still *active*; A is deleted since there is no (more) *active* `AirFrame` it intersects with.

t_6 : C ends and is deleted since there is no *active* `AirFrame` it intersects with; B is deleted since C is not *active* anymore.

Given the above example, consider B to be an `AirFrame` which is actually being received (not treated as noise) and thus evaluated by the `Decider` (at time t_5). Since `AirFrame` B as well as the interfering `AirFrame`s A and C have to be taken into account in order to calculate the SINR, all of those have to be accessible to the `Decider`. This is why `ChannelInfo` does not delete an `AirFrame` as long as there is an *active* one overlapping in time (in the example, A is not deleted as long as B is *active*). Thus `ChannelInfo` is able to hand over a currently received `AirFrame` (B) together with all interfering `AirFrame`s (A and C) on demand.

2.3 Signal Concept

Every `AirFrame` contains a `Signal` which describes the actual physical signal sent over the channel. While it is created at the senders MAC layer, it is heavily affected by the receivers `AnalogueModels` which model the influences of the wireless environment it travels through.

To represent a physical signal the `Signal` class contains `Mapping` instances for transmission power, bit-rate, attenuations and receiving power which all represent mathematical mappings defining the according data over time and maybe more dimensions like frequency or space. The lower part of Figure 2 shows the relationships of the different classes: Each `AirFrame` contains a `Signal` object, which in turn contains various `Mapping` objects describing the different properties of the physical signal.

While transmission power and bit-rate `Mappings` are added to the `Signal` by the MAC layer module of the sender, the attenuation `Mappings` are defined and added by the `AnalogueModels` used at the receiving physical layer module. The receiving power `Mapping` is defined by multiplying all of the attenuation `Mappings` elementwise with the transmission power `Mapping`. To avoid unnecessary calculations this is done only on demand. The receive power is used by the `Decider` to calculate SINR and to perform the bit-error analysis. Details of the `Mapping` class and its implementation can be found in Section 5.

3. RADIO AND ANALOGUE MODELS

In this section we describe how the influence on a `Signal` on its way from the sender to the receiver(s) is considered and realized in our model. When transmitted by the wireless channel, a `Signal` is attenuated due to several effects which are modeled and applied to the `Signal` by `AnalogueModels`. Furthermore the state of the receivers `Radio` possibly affects the transmitted `Signal`. So this state is represented by the `RadioStateAnalogueModel` and applied accordingly.

3.1 Radio

The `Radio` of a NIC is part of the physical layer-module and implemented as a state-machine. There are two main functionalities for the `Radio` module: simulation of radio switching times and simulation of the effects a radio has on signal reception.

In state-of-the-art hardware, the time it takes to switch a radio from transmit to receive or sleep are usually very small and thus are often neglected in simulation. However, there are scenarios where switching times should not be neglected, since they can have significant influence on the simulation results. In MiXiM we thus support both scenarios: simulation of switching-times for a radio-state transition as well as zero-time switching. The MAC layer can switch the `Radio` to another state by calling `setRadioState()` on the `MacToPhyInterface`. In case of a non-zero switching times it is

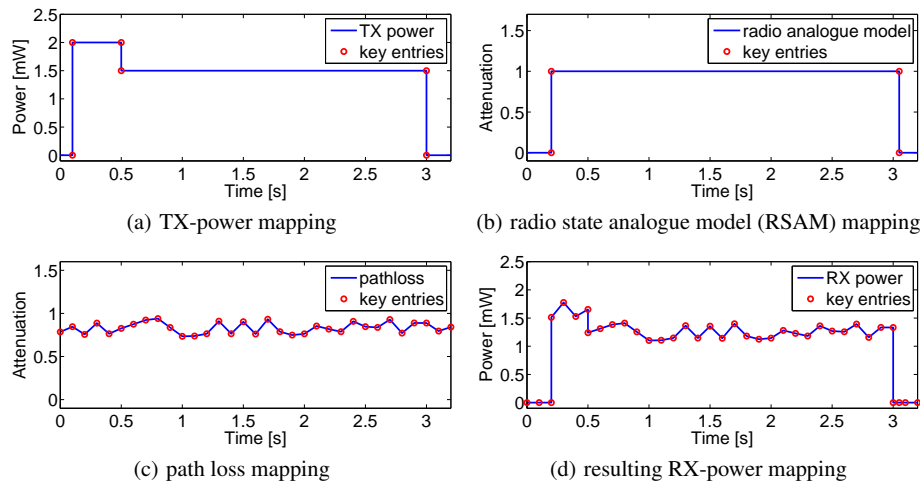

Figure 5: TX-power mapping multiplied with RSAM mapping

notified by a control-message of kind `RADIO_SWITCHING_OVER` as soon as the simulated switching process has finished. For zero switching times, there are no control messages sent and thus the performance (speed) of the simulation is not degraded.

Most radios are half-duplex, meaning they can only send or receive at a time, but not concurrently. However, there also exist duplex radios which can concurrently send and receive. The standard Radio module in MiXiM is half-duplex but can be easily extended for full-duplex operation. In the following, we will focus on half-duplex radios.

The state of the Radio affects a received signal. If in send, sleep or off mode, no signal can be received. In MiXiM, this is represented by the `RadioStateAnalogueModel` which returns dynamically created attenuation-step-mappings. The Radio tracks the states it is in over time and maps the several states to attenuation values. If the Radio is in the receive state, there is no attenuation, otherwise the signal is attenuated by 100%. This concept can be easily extended to support e.g. two independent antennas by exploiting the spatial dimension of the attenuation mapping.

3.2 Analogue Models

The `AnalogueModels` are used to simulate effects like path-loss, shadowing and fading which affect the signal during its transmission. A physical layer can contain an arbitrary number of `AnalogueModels`, which can be plugged-in as described in Section 2.1. A `Signal` arriving at the physical layer will be subsequently processed by all `AnalogueModels`.

The `AnalogueModel` class itself is only an interface defining a `filterSignal()`-method which takes the `Signal` to be processed as an argument. Actual implementations of the interface implement this method by taking the information they need from the passed `Signal` (like start and end time of the `Signal` or the `HostMove` of the sender), create an attenuation `Mapping` which describes the attenuation caused by the effect this `AnalogueModel` simulates and add it to the `Signals` attenuation list. To describe the attenuation mapping for the signal the `AnalogueModel` can use an own `Mapping` implementation or only calculate the attenuation values of some points of interest and put them into one of the default `Mapping` implementations. For details refer to Section 5.

Figure 5 shows an example of a TX-power signal, which is filtered by two `AnalogueModels`. The step-function in Figure 5(b)

represents the attenuation of a `RadioStateAnalogueModel`. The state of the radio changes at $t = 0.2$ to RX and at $t = 3.05$ back to TX or SLEEP. In Figure 5(c) a simple path-loss `AnalogueModel` is shown. The resulting RX-power is shown in Figure 5(d).

Note, that we represent attenuation as a quantity between 0 and 1 without a unit. An attenuation of 100 % is represented as 0 and no attenuation (0 %) as 1. The advantage of this approach is that the resulting RX-mapping can be simply calculated by multiplying the TX-mapping with all attenuation mappings.

4. DECIDER

The decider is the evaluation component of the physical layer. It is responsible for evaluating received `Signals`, which includes categorizing arriving `Signals` as interference or messages to receive and, at the end of receiving a message, calculating the bit-errors for that message. Another task of the decider is the evaluation of the channel, i.e. to perform carrier sensing and report the channel state to the MAC layer.

4.1 AirFrame Evaluation

Each `AirFrame` is processed several times by the `processSignal()`-method of the decider, as indicated in Figure 3. The number of times it is processed (and also how it is processed) actually depend on the specific `Decider` implementation. However, the example below represents the most common case and also reflects the mandatory processing events for each `AirFrame`.

1. Upon the reception of the first bit of an `AirFrame` the decider has to process the `Signal` of that `AirFrame` for the first time. It basically only has to decide, at which point in time it can decide whether the packet should be treated as noise or not and returns this time-point to the physical layer. Usually, the time to decide whether to receive an `AirFrame` or treat it as interference / noise is after the physical layer preamble is completely received. However, the `Decider` can also make the decision immediately or at any other point in time.
2. The next time the decider gets the `Signal`, it has to decide whether the `AirFrame` is considered interference or whether it is actually being received. This is done by evaluating the

SINR-Mapping up to the current time (e.g., end of the preamble). To do so, it requests all `Signals` intersecting with this time-period from `ChannelInfo`. In the example of Figure 4 this would be the interval between t_1 and t_2 (assuming that t_2 denotes the end of the preamble of `AirFrame B`). The `Decider` has to calculate the received power (as shown in Figure 5) in that time-interval for both, `AirFrame A` and `B`. It obtains the SINR by dividing the receive power of `AirFrame A` by that of `B`.

If the `AirFrame` is considered to be interference, the `Decider` returns a special signal to the physical layer, indicating that does not want to get this `AirFrame` again for processing. If the `AirFrame` is considered to be a message to receive, the decider will return the end of the `Signal` to the physical layer as the next point in time it wants to process the `Signal`.

3. When the `AirFrame` is completely received, the decider has to evaluate the contained `Signal` for bit-errors. It has to create the SINR-Mapping (as in the previous step), but this time for the whole duration of the `Signal`. In the example of Figure 4 this means that also the receive power of `AirFrame C` has to be calculated.

How the SINR is used to determine the bit-errors of the `AirFrame` depends on the specific `Decider` implementation. In the simplest case, the SINR is just checked against some threshold and the `AirFrame` is considered lost if the threshold is exceeded. Another option is to determine a bit-error probability based on bit-error curves.

The `Decider` has to pass the decapsulated MAC-packet up to the MAC layer together with a `DeciderResult`. The `DeciderResult` contains the evaluation data for the MAC-packet (packet lost / correctly received, number of bit-errors, etc.) where the specific evaluation data again depends on the concrete `Decider` implementation.

4.2 Channel Sensing

As mentioned above the decider is also responsible for evaluating the wireless channel, i.e. deciding whether the channel is busy or idle at a specific point in time. This is an important functionality provided to the MAC layer which is needed for Carrier Sense Multiple Access (CSMA) protocols.

In a real system such a channel sensing takes time, however this time is often negligible and thus not accounted for in simulation. MiXiM provides both possibilities: channel sensing in zero-time as well as simulation of the channel-sensing process over time.

To get the instantaneous state of the channel without simulating time for the sensing process, the MAC layer can use the method `getChannelState()` offered by the `MacToPhyInterface`. It immediately returns a so-called `ChannelState`-object containing the channel state information. The other option for the MAC layer is to send a message of kind `CHANNEL_SENSE_REQUEST` to the physical layer through the control-channel. The `Decider` will then sense the channel for the specified amount of time and answer by sending a control message containing the `ChannelState`-object reflecting the channel state.

A `ChannelState`-object itself contains an RSSI value and a flag that indicates whether the channel is considered idle or not. The semantic of this idle-flag depends on the implementation of the particular decider. The `BaseDecider` considers the channel idle if no `Signal` is received at the moment of the request.

5. MAPPING

Many aspects of simulating the wireless transmission process can be expressed by mathematical mappings and operations on them. The signal sent to the channel might consist of a mapping for the power $f_{TX} : time \times frequency \times space \rightarrow power$ and one for the bit-rate $f_{bitrate} : time \times frequency \times space \rightarrow bitrate$ (in MiXiM the bit-rate represents the coding / modulation combination used for a signal). The attenuation defined by the `AnaLogueModels` can be represented by further mappings $f_{att_{1..n}} : time \times frequency \times space \rightarrow attenuation$ defining an attenuation factor varying in time, frequency and space. The resulting receiving power can then be calculated by multiplying the attenuation mappings element-wise with the power mapping which results in another mapping $f_{RX} : time \times frequency \times space \rightarrow power$ where $f_{RX} = f_{TX} \times \prod f_{att_{1..n}}$. Further the SINR needed by most `Deciders` to evaluate if a signal was received correctly is calculated by dividing the receiving power of the signal to evaluate (f_{RX_s}) by the receiving power of the interference, which is the summed up receiving power of every signal interfering with the signal to be evaluated. So we get further element-wise operations on mappings: $f_{SINR} = \frac{f_{RX_s}}{\sum f_{RX_{noise_{1..n}}}}$. The `Decider` then has to evaluate the different SINR values in time, frequency and space inside the SINR mapping.

The mapping abstraction enables us to compute the SINR of a received packet at any interesting point in time, frequency and space in a consistent fashion. For systems that are not as complex, the consistency of the abstractions allows us to use much simpler models without paying an inadequate price for the generalization.

In the following sections we describe how we implement the mapping abstraction and the necessary operations in MiXiM.

5.1 Requirements for a Mapping

In order to define a `Mapping` class for MiXiM, we first need a list of requirements it has to fulfill.

First of all, the `Mapping` class should support almost arbitrary domains. The simplest case is just a mapping from time to power or bit-rate, i.e. $f : \mathbb{R} \rightarrow \mathbb{R}$. But we can also have mappings defined in time, frequency and space $f : \mathbb{R} \times \mathbb{R} \times \mathbb{R} \rightarrow \mathbb{R}$. So while the codomain stays the same the domain can change. Generally, we can assume that a codomain of a single real value is sufficient because if we need to represent something like $f : \mathbb{R} \rightarrow \mathbb{R} \times \mathbb{R}$ we could just use two separate mappings $f_1 : \mathbb{R} \rightarrow \mathbb{R}$ and $f_2 : \mathbb{R} \rightarrow \mathbb{R}$ to achieve the same.

Naturally, the `Mapping` class also has to provide the mapping functionality itself, meaning given a number of arbitrary argument values in the mappings domain it has to return the specific mapped value for these arguments. This can either be done by using the passed arguments and maybe some other parameters to evaluate a mathematical formula and return the result, or by a lookup of the value for the specified argument. Note, that if there is no value defined for this specific argument, the `Mapping` class also has to be able to return a value by interpolating between adjacent arguments.

At last, since the `Decider` has to evaluate the values of an SINR mapping but probably can't check every possible point in time, frequency and space, the `Mapping` class has to provide the possibility to iterate over a set of given arguments.

5.2 Mapping Class Overview

The above requirements led to the modeling of the `Mapping` interface as shown in Figure 6. The most important class members are shown in Figure 7.

A single dimension (like time) is represented by the `Dimension` class. The domain of a `Mapping` can consist of more than one di-

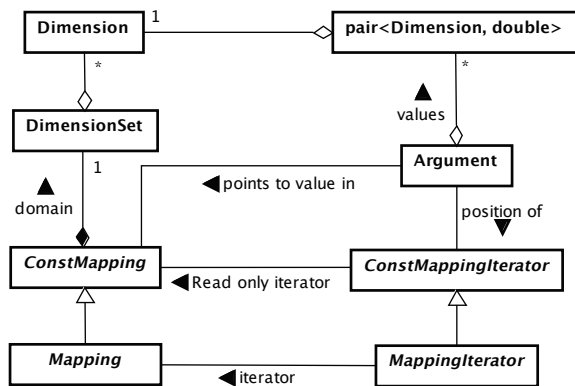

Figure 6: The Mapping model

dimension (e.g. time and frequency) and is defined by the `DimensionSet` class which contains one or more `Dimension` objects. This enables us to define arbitrary domains and fulfill the above requirements.¹ Externally, a `Dimension` is represented by a case sensitive name (like "frequency"), internally a simulation wide static unique id is used. Since this id is used to define the iteration order for multi dimensional mappings (see section 5.3) it is important to know that the time dimension always gets zero as id and every other id is an increasing integer assigned at the first creation of a `Dimension` object for a dimension.

To be able to define positions in Mappings with arbitrary domain we define the `Argument` class. It maps from every `Dimension` of a domain to a value defining the position of the `Argument` instance in that dimension.

The `Mapping` and `ConstMapping` classes are interfaces which define the methods a class has to provide to be able to represent a mathematical mapping. The `ConstMappingIterator` and `MappingIterator` classes are interfaces as well and define the methods provided by an iterator for a mapping to be able to iterate over the points of interest of a mapping. The use of interfaces separates the information of how the data of a mapping is created from the way it is accessed. This enables us to provide methods which are generally applicable for any mapping (e.g. mathematical operations). It also allows implementing different kinds of data sources for a mapping (e.g. a mathematical formula or a number of interpolated key entries).

The difference between the Const- and non-Const-version of the interfaces is that the Const-version misses the `setValue()`-method so implementations do not have to provide a way to change the represented mapping arbitrarily. This is useful if a formula is used to represent the mapping where the parameterization can be changed but not the values themselves directly.

An important design decision we made is that every `Mapping` has to contain the time in its domain. Since signals are always defined over time and almost any mapping refers to a signal this does not constrain the user too much while it enabled us to use the more accurate `simtime_t` as type for positions in the time dimension.

5.3 Mapping Iteration

While it is trivial to iterate over a one dimensional mapping be-

¹Note, that we usually refer to the domains "time", "frequency", and "space" in this paper because these will be the domains mainly used in MiXiM.

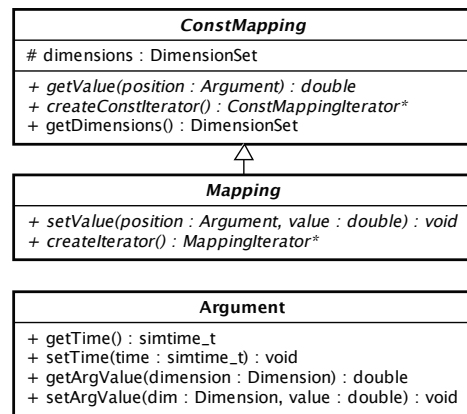

Figure 7: The Mapping members

cause there exists an unique order of the values, iteration over multidimensional mappings is more challenging.

We used the ordering of the `Dimensions` at this point to get a well defined iteration order every `MappingIterator` has to provide. A mapping with a multidimensional domain, e.g., $f : time \times freq \times space \rightarrow \mathbb{R}$ can also be represented by a nesting of mappings with a one dimensional domain $f : space \rightarrow (freq \rightarrow (time \rightarrow \mathbb{R}))$. So f would map from a number of points in space to a number of "sub-mappings" which again map from a number of points in frequency to a number of further "sub-mappings" which finally map from a number of points in time to an actual value.

The ordering feature of the `Dimension` class is used to define the ordering used to iterate over the mapping. Let us assume the dimensions are ordered $space > frequency > time$. We would start iterating at the first position in space and directly go down to the according sub-mapping (frequency). Here we would take the first position in frequency and go down to its according sub-mapping which is a one dimensional time mapping and has a well defined iterator. When we reach the end of this sub-mapping we go back to the "parent-mapping" and go to its next position in frequency, which again points to a time sub-mapping. After all frequency sub-mappings are handled, the same process is repeated for the next point in the space sub-mapping. This gives a well defined way to iterate over arbitrary dimensional mappings and also enables us to define a "bigger than"-comparison of `Argument`-objects.

5.4 Mapping Implementations

There are several implementations of the `Mapping` interface already included in the current version of MiXiM. These implementations actually already support most of the scenarios we can think of. Writing own `AnalogueModels` or creating own `Signals` is simply done by using these implementations or sub-classing from them.

The first implementation is the `SimpleConstMapping`. It is meant to be used as a base class for any `ConstMapping` implementation which is based on a mathematical formula and therefore can be calculated every time its value at a specific position is needed. The only method that has to be implemented is the `getValue()`-method. Additionally, key entries have to be defined in order to be able to iterate over the `Mapping`. An implementation of the `getValue()`-method takes the values of the passed position and maybe some parameters previously set during initialization to calculate the value of the represented mapping at the position specified

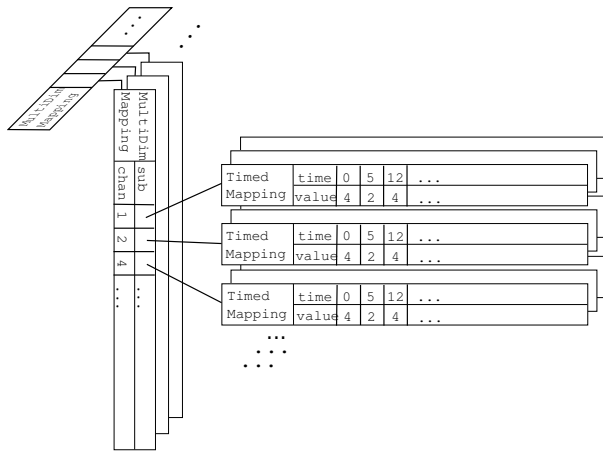

Figure 8: MultiDimMapping structure

by the passed Argument.

The next implementation provided is the `TimeMapping` class. It is intended to be used for any mapping where time is the only domain. The `TimeMapping` is implemented by using an extended `std::map` which is able to interpolate between entries with a given interpolation method to return values for positions for which no values have been set.

The last implementation, `MultiDimMapping`, is used to represent any Mapping whose domain has more dimensions than time. It uses the nesting-method explained in Section 5.3 meaning it represents a multidimensional mapping by mapping from the key entries in one dimension to a number of sub-mappings which again are mappings from the key entries in their dimension to a number of sub-mappings until the time dimension is reached (which always is the last since its id is zero). The mappings of the time dimension are not mappings to a further sub-mapping but to an actual value. This results in the tree-like structure shown in Figure 8. Each `MultiDimMapping` instance represents a mapping from one dimension to a number of sub-mappings. These sub-mappings can then be instances of further `MultiDimMappings` or they can be `TimeMappings` which represent the leaves of the tree-like structure. The actual mapping from the positions in the current dimension to the sub-mappings is done by the same extended `std::map` used for the `TimeMappings` with special interpolation methods which are able to interpolate a whole sub-mapping.

5.5 Mapping Utilities

There are a number of utility methods provided in a `MappingUtils` class. These methods enable the easy creation and combination of mappings without having to worry about the implementation details.

There are methods which add, subtract, divide or multiply two `ConstMapping` instances element-wise and return the result in a new `Mapping` instance. These methods are using the same `applyElementwiseOperator()`-method which applies a passed operator to the values at every key entry of both of the passed mappings and returns the result in a new `Mapping` instance. The passed operator can be any operator which takes two double values and returns a new double value, e.g., the `std::plus` or `std::multiplies` operator. The set of key entries of the result is the union of the sets of key entries of the passed mappings.

Figure 5 shows an example of the multiplication of 1-dimensional

mappings and the resulting key entries. Figure 5(a) shows a power mapping using a different power for the preamble and the rest of the message. Figure 5(b) shows the radio state model of the receiver and Figure 5(c) a simple path-loss model. Note that the path loss model has a lot more key entries than the power and radio state models. Figure 5(d) shows the multiplication result and its key entries. In this 1-dimensional case the resulting mapping is a `TimeMapping`-instance which interpolates between the union of the key entries of the input methods. If the result is multidimensional an instance of `MultiDimMapping` is returned.

The `applyElementwiseOperator()`-method can even operate if the passed `ConstMappings` are not of the same domain, as long as the domain of the second `ConstMapping` is a subset of the first one. This is, e.g., useful for using a simple `AnalogueModel` which only defines an attenuation mapping over time together with a more complex `Signal` whose power mapping is defined over time and frequency. This would obviously imply the assumption that the attenuation over time defined by the `AnalogueModel` is identical for every frequency.

An example for the multiplication of a two-dimensional power mapping with a one-dimensional `RadioStateAnalogueModel` is shown in Figure 9. Figure 9(a) shows the power mapping defined over time and frequency where the dots mark the key entries. Figure 9(b) shows the radio state mapping which is only defined in the time domain. To be able to multiply the one-dimensional radio state mapping with the two-dimensional power mapping the method “copies” the radio state mapping for every frequency the power mapping has key entries in, in this case for frequency of 2.412, 2.422 and 2.432. The result can be seen in Figure 9(c). Then the power mapping and the “filled up” radio-state mapping can be multiplied as usual by multiplying the values at the key entries defined by both mappings. The result is shown in Figure 9(d).

The `MappingUtils` class also provides a method called `createMapping()` which takes a `DimensionSet` and an interpolation method and returns an appropriate `Mapping` instance (which will be either a `TimeMapping` or a `MultiDimMapping`, depending on the passed `DimensionSet`). So the user doesn’t have to care about correct creation of the `Mapping`. The available interpolation methods are “STEPS” which interpolates by using the next smaller key entry as value (resulting in a step-like function), “NEAREST” which uses the nearest key entry as value and “LINEAR” which interpolates linearly between the next smaller and the next bigger key entry.

6. CONCLUSION

In this paper we present an architectural overview of the modeling and the implementation of the physical layer within the MiXiM simulation framework. MiXiM is a simulation framework supporting wireless transmissions within OMNeT++. One of the main advantages of the presented approach is that it supports modeling of arbitrary complex signals (in time, frequency and space) but at the same time also supports simple single-frequency, single-(isotropic)-antenna models without carrying the overhead of complex models.

The modular structure of MiXiM enables a high degree of model reuse and the almost arbitrary combination of models. The same simulation can be carried out with a simple path-loss model or with complex shadowing and fading models just by adding / removing the appropriate models in the configuration file.

MiXiM already contains a number of `AnalogueModel` implementations for path-loss, shadowing, and fading as well as popular standards as IEEE 802.11 and 802.15.4 (ported from the Mobility Framework [2]). However, the main focus so far was on the archi-

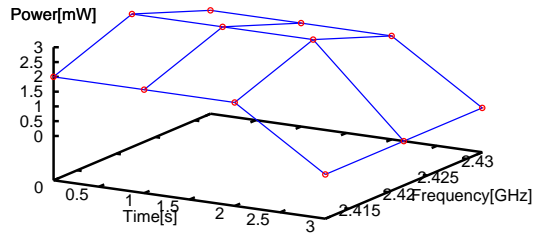

(a) two dimensional TX-power mapping

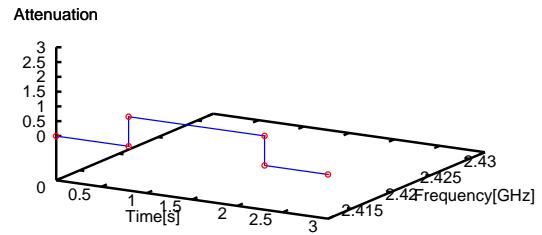

(b) one dimensional radio state analogue model (RSAM) mapping

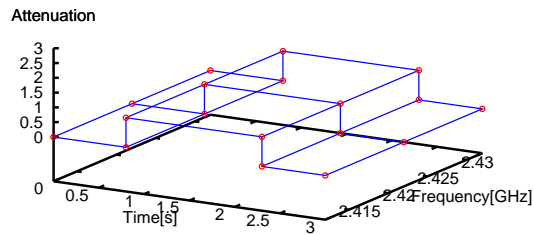

(c) filled up two dimensional RSAM mapping

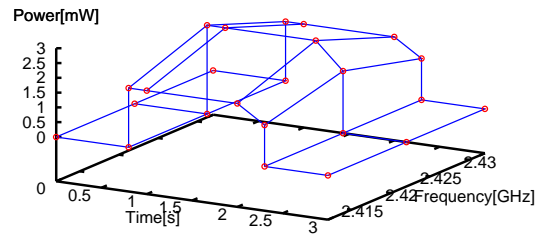

(d) resulting two dimensional RX-power mapping

Figure 9: 2D TX-power mapping multiplied with 1D RSAM mapping

tektural framework and we hope more models will be added by the community.

7. REFERENCES

- [1] MiXiM simulator for wireless and mobile networks using OMNeT++. [online]. Available: <http://mixim.sourceforge.net/>.
- [2] Mobility framework (MF) for simulating wireless and mobile networks using OMNeT++. [online]. Available: <http://mobility-fw.sourceforge.net/>.
- [3] A. Köpke, M. Swigulski, K. Wessel, D. Willkomm, P. T. Klein Haneveld, T. E. V. Parker, O. W. Visser, H. S. Lichte, and S. Valentin. Simulating wireless and mobile networks in OMNeT++ the MiXiM vision. In *Proceeding of the 1. International Workshop on OMNeT++*, Mar. 2008.
- [4] A. Varga. *OMNeT++ Discrete Event Simulation System*. Available: <http://www.omnetpp.org>.