

# Impacts of Erasure Coding on Robustness against Molecular Packet Losses in Aqueous, Collisional Environments

Hiroaki Egashira  
Shibaura Institute of Technology  
Dept. of Electrical Engineering and  
Computer Science  
Tokyo, Japan  
University of Massachusetts, Boston  
Dept. of Computer Science  
Boston, MA, USA 02125  
hiroaki@cs.umb.edu

Junichi Suzuki  
University of Massachusetts, Boston  
Dept. of Computer Science  
Boston, MA, USA 02125  
jxs@cs.umb.edu

Jonathan S. Mitzman  
University of Massachusetts, Boston  
Dept. of Computer Science  
Boston, MA, USA 02125  
tolkien@cs.umb.edu

Tadashi Nakano  
Osaka University  
Graduate School of Frontier  
Biosciences and Institute for  
Academic Initiatives  
Osaka, Japan  
tadasi.nakano@fbs.osaka-u.ac.jp

Hiroaki Fukuda  
Shibaura Institute of Technology  
Dept. of Information Science and  
Engineering  
Tokyo, Japan  
hiroaki@shibaura-it.ac.jp

## ABSTRACT

This paper considers diffusive molecular communication where biologically-enabled machines (or bio-nanomachines) exchange information by means of molecules in aqueous environments. It is known that molecular communication is inherently stochastic and unreliable, thereby significantly degrading communication performance such as latency and jitter. This paper focuses on robustness against molecule losses and investigates a robustness enhancement protocol that performs forward error correction. The transmitter bio-nanomachine encodes molecules in a redundant manner with parity-check erasure codes, and the receiver bio-nanomachine recovers the information embedded in lost molecules. Simulation results show that the proposed protocol enhances robustness against molecule losses and in turn improves communication performance.

## CCS CONCEPTS

•Networks → Network protocols; Network reliability; Error detection and error correction; Network performance analysis;

## KEYWORDS

Molecular Communication, Robustness, Forward Error Correction

---

Permission to make digital or hard copies of all or part of this work for personal or classroom use is granted without fee provided that copies are not made or distributed for profit or commercial advantage and that copies bear this notice and the full citation on the first page. To copy otherwise, to republish, to post on servers or to redistribute to lists, requires prior specific permission and/or a fee.  
BICT 2017, March 15-16, Hoboken, United States  
Copyright © 2017 ACM 978-1-63190-148-5

## 1 INTRODUCTION

Molecular communication is one of a few options to network biologically-enabled machines (or *bio-nanomachines*), which can be designed as modified biological cells, artificial cells (cell-like artificial structures engineered with biological materials) or hybrids of artificial nanostructures and biological materials [1, 10, 19, 20, 27]. Bio-nanomachines are nano-to-micro scale devices that exchange information by means of molecules and perform simple computation, sensing and/or actuation tasks. Molecular communication is expected to enable various biomedical and healthcare applications such as in-body physiological sensing, biomedical anomaly detection, targeted drug delivery, medical surgeries with cellular and molecular-level precision, artificial morphogenesis and neural signal transduction [1, 18, 20, 28].

This paper considers short-range (up to 100  $\mu\text{m}$ ) molecular communication where information-carrying molecules (or *information molecules*) propagate in aqueous environments subject solely to the laws of diffusion. Inherent characteristics of diffusive molecular communication in aqueous environments are stochastic molecular propagation, molecule-to-molecule collisions and environmental noise. They cause extremely long delay, large jitter, high molecule loss rate and low capacity [24, 26].

This paper focuses on robustness against molecule losses and investigates a robustness enhancement protocol for diffusive molecular transmission in collisional environments where molecules collide with each other. It performs forward error correction (FEC) in which the transmitter bio-nanomachine (Tx) encodes molecules in a redundant manner with error-correcting codes (ECCs) and the receiver bio-nanomachine (Rx) recovers the information embedded in lost molecules. This paper examines simple parity-check erasure codes as ECCs. Simulation results demonstrate that the proposed protocol enhances robustness against molecule losses and in turn improves communication performance such as latency and jitter.

The simulation results also reveal how FEC overhead and molecule redundancy impact communication performance.

## 2 BACKGROUND AND RELATED WORK

Applications of molecular communication have been considered in various domains [1, 18]. This section briefly summarizes a few biomedical and healthcare applications.

*Physiological monitoring:* A specific type of molecules can serve as a bio-marker for a disease or a certain physiological condition in the body. Implanted bio-nanomachines may exploit sensory components (e.g., biosensors) to detect specific molecules, gather/aggregate information about the detected molecules (e.g., concentration and spatial distribution of molecules) and utilize molecular communication as a means of delivering the information to subdermal devices, which in turn communicate to on-body external devices [8, 18].

*Drug delivery:* Drug delivery systems facilitate the administration and distribution of drugs in the body. Implanted bio-nanomachines leverage natural molecular signals in the body, or molecular signals released by other bio-nanomachines, to pinpoint the target locations to release drugs, thereby avoiding/alleviating side-effects at non-target locations. Molecular communication can be applied to identify target sites/signals [4, 22] and release drug molecules upon identifying target sites or signals [21].

In the area of molecular communication, major research efforts have focused on the physical layer's characteristics such as channel capacity, latency, signal attenuation and energy requirements (e.g., [6, 17, 20, 24, 26]). This paper sits on these existing work to investigate a higher-layer issue: reliable molecular transmission via robustness enhancement against molecule losses.

There exist several relevant work to enhance the reliability of short-range molecular communication in aqueous environments [3, 7, 16, 21, 30]. Nakano et al. [21] and Felicetti et al. [7] study feedback-based rate control schemes for diffusive molecule propagation. Those schemes are designed to ensure delivering a given number of information molecules to the receiver bio-nanomachine (Rx) while preventing the transmitter bio-nanomachine (Tx) from transmitting molecules faster than the Rx reacts. Nakano et al. examine both positive and negative feedback schemes [21], and Felicetti et al. examine a negative feedback scheme [7].

While in-sequence delivery of information molecules is out of the scope of [7, 21], Wang et al. [30], Bai et al. [3] and Mitzman et al. [16] study in-sequence and at-least-once delivery schemes with positive feedbacks. The Rx is designed to explicitly acknowledge information molecules and request the Tx to retransmit lost ones based on Stop-and-Wait Automatic Repeat Request (SW-ARQ) [5]. (Implicit acknowledgement is used in [7, 21].) Diffusive molecular transports are considered in [30] and [3]. Mitzman et al. consider diffusive, directional and diffusive-directional hybrid transports [16].

This paper approaches reliability in molecule transmission with forward error correction (FEC) instead of feedback-based schemes, which require bi-directional channels between the Tx and the Rx. In this paper, erasure coding allows the Rx to recover lost information molecules without requesting the Tx to retransmit them. Only a forward channel is assumed from the Tx to the Rx by eliminating the

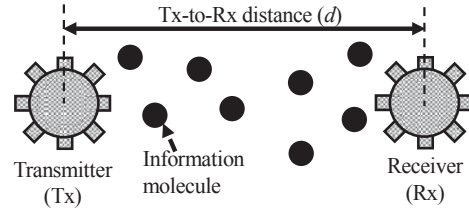

Figure 1: Diffusive Molecular Propagation

Rx-to-Tx reverse channel at the cost of a fixed, higher forward channel bandwidth. This paper is similar to [2, 3, 11–15] in that those papers utilize FEC. Hamming codes, cyclic redundancy check (CRC) codes, self-orthogonal convolutional codes (SOCCs) and minimum energy codes (MECs) are used for the Rx to detect and correct bit errors in information molecules in [2, 3, 11–15], respectively. Recovery of lost molecules is out of their scope. Collisions among molecules are not considered.

Furubayashi et al. propose packet fragmentation and reassembly in molecular communication [9]. This paper shares the same assumptions for packetized molecular communication with [9]. It complements the findings in [9], which are obtained through numerical analysis with a one-dimensional, collision-free environment, by simulating three-dimensional molecular diffusion in a collisional environment where collisions occur among molecules. Although Furubayashi et al. consider packet reassembly at the Rx, recovery of lost molecules (i.e., lost packets) is out of their scope.

## 3 THE PROPOSED PROTOCOL DESIGN

This section describes the assumptions for and the design of the proposed robustness enhancement protocol.

### 3.1 Communication Model

Fig. 1 shows an schematic overview of short-range diffusive molecule communication in an aqueous environment. It consists of information molecules that carry the messages (information) to be transmitted, the transmitter bio-nanomachine (Tx) that releases information molecules, the receiver bio-nanomachine (Rx) that detects and captures information molecules, and the environment that information molecules propagate through.

Given wet laboratory implementations of molecular communication (e.g., [23]), this paper assumes DNA molecules as information molecules that can contain messages by means of nucleotide sequences. DNA is structurally defined as a linear chain of repeating units of deoxyribonucleotide. Each deoxyribonucleotide is composed of a nucleobase, either adenine (A), guanine (G), cytosine (C) or thymine (T), as well as a five-carbon sugar called deoxyribose, and a phosphate group. A nucleobase of DNA encodes 2 bits of information because there are four choices (A, G, C and T), and it has a length of approximately 0.34 nm per nucleobase [19]; thus, up to 5,882 bits/ $\mu\text{m}$  can be achieved. Molecular communication with large (heavy) molecules like DNA molecules have advantages over conventional molecular communication with small (lightweight) molecules (e.g., [24, 26]) in that large molecules can carry high-density information.

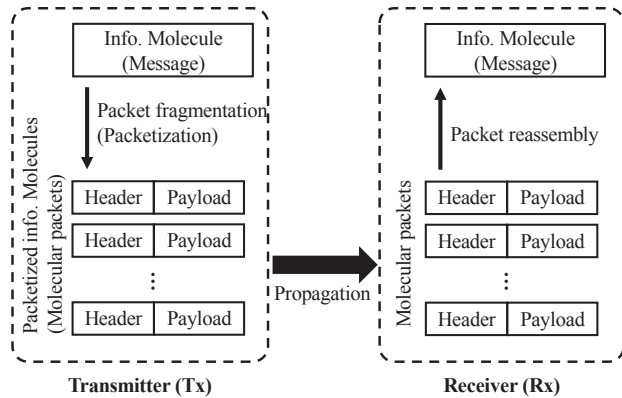

Figure 2: Packet Fragmentation and Reassembly

Promising approaches to engineer bio-nanomachines with communication capability include the modification of biological cells and the production of artificial cell-like structures using biological materials (e.g., a vesicle embedded with proteins) [20]. This paper assumes that bio-nanomachines are realized as modified biological cells, which are known to potentially possess various communication-related functions including a transmission function to synthesize and release specific molecules, a reception function to capture molecules, logic gates to trigger programmed chemical responses upon receiving molecules, toggle switches (i.e., 1-bit memories) to retain communication-related states (e.g., ready-to-transmit and in-transmission/waiting states), and oscillators (i.e., clocks) to control the temporal timing of releasing molecules.

This paper assumes a pure random walk for diffusive molecule propagation. The Rx is assumed to capture an information molecule when it has a physical contact with the molecule. Information molecules are assumed to diffuse in a bounded three-dimensional aqueous environment. Diffusive movement is governed by the diffusion coefficient  $D$  on each dimension:

$$D = \frac{\partial x^2}{2\partial t} \quad (1)$$

$x$  denotes the distance of molecular movement during an amount of time  $t$ . When an information molecule contacts a noise molecule, it randomly moves to another position with  $D$ . Information molecules collide with each other.

### 3.2 Packetization of Information Molecules

The proposed protocol employs the notion of packet fragmentation and reassembly [9]. As Fig. 2 shows, the Tx *packetizes* a large information molecule (i.e., a large DNA molecule containing a long nucleobase chain) into smaller pieces (i.e., smaller/shorter DNA molecules, each of which contains shorter nucleobase chains) and propagate the packetized information molecules in the environment. The Rx receives these packetized information molecules (or *molecular packets*) and reassembles the original information molecule. Packetization of information molecules is motivated by the findings that, compared to larger ones, smaller DNA molecules diffuse faster [25] and arrive at the Rx with higher probability [9].

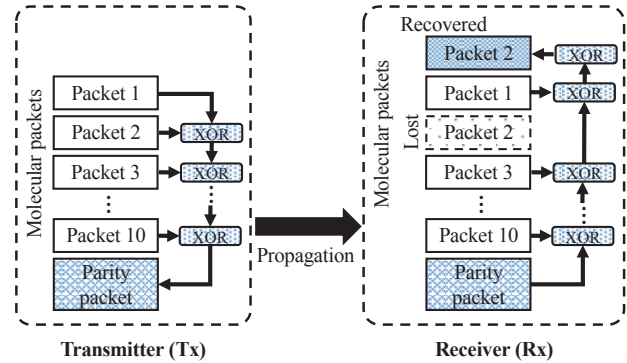

Figure 3: Parity-check Erasure Coding

Each molecular packet is assumed to be uniquely identifiable. It consists of a payload and a header (Fig. 2). A payload contains a fragment of the original message. A header contains control information such as a receiver address to which the molecular packet is delivered, an identifier (or sequence number) for the original message that the molecular packet belongs to, and an identifier for the molecular packet.

The packet fragmentation and reassembly may be implemented by exploiting enzymes from biological cells, e.g., restriction enzymes to cut a DNA molecule into smaller fragments, and DNA ligases to join two DNA fragments into a larger one. Restriction enzymes may be embedded in the Tx and DNA ligases in the Rx. Chemical reactions to implement the packet fragmentation and reassembly are simple and require these enzymes and a few small cofactors. The biochemical reaction to cut a DNA molecule into fragments is a hydrolysis reaction, which requires no energy. On the other hand, the biochemical reaction to concatenate DNA molecules requires chemical energy. The energy cost required for the proposed molecular communication scheme increases linearly with respect to the number of fragments.

### 3.3 Parity-check Erasure Coding

The proposed protocol leverages parity-check erasure coding as a forward error correction mechanism. The Tx applies exclusive-or (XOR) operations to a group of  $m$  molecular packets to obtain  $k$  fixed-length *parity codes* and generates extra  $k$  packets, called *parity packets*, which contain the parity codes. The Tx propagates  $m + k$  packets to the environment. The Rx can tolerate up to  $k$  packet losses. It can recover the original  $m$  molecular packets with  $(m - k)$  packets. Packet code rate (PCR) is denoted as  $k/m$ .

Fig. 3 illustrates a simple example where  $m = 10$  and  $k = 1$  (PCR = 10%). The Tx propagates 11 packets in total: 10 molecular packets and one parity packet that contains bitwise XOR on the 10 molecular packets as parity code. The Rx can recover one lost packet (Packet 2 in Fig. 3) with nine molecular packets and one parity packet. In order to increase PCR, the number of molecular packets is decreased to produce parity code. For example, in Fig. 3, two parity packets can be generated by producing parity code from five molecular packets (PCR = 20%). five parity packets can be generated by producing parity code from two packets (PCR = 50%).

## 4 SIMULATION EVALUATION

This section evaluates the proposed robustness enhancement protocol through simulations. Table 1 shows simulation parameter settings, which follow findings in biomedical engineering (e.g., [25]). Every result is shown based on 1,000 independent simulations.

**Table 1: Parameter Settings**

Parameter	Value
Size of the environment	150 $\mu\text{m}$ x 150 $\mu\text{m}$ x 150 $\mu\text{m}$
Diameter of Tx and Rx	5 $\mu\text{m}$
Tx to Rx distance ( $d$ )	30, 50, 70 and 90 $\mu\text{m}$
Length of an info. molecule ( $L_m$ )	10.2 $\mu\text{m}$
Degree of packetization ( $n$ )	1, 10 and 100
Diffusion coefficient of a mol. packet ( $D$ )	0.70, 2.73 and 9.84
Diameter of a molecular packet ( $R \times 2$ )	0.98, 0.25 and 0.07 $\mu\text{m}$
Parity packet rate (PCR)	0, 10, 20 and 50 %
# of duplications of an info. molecule	1, 10 and 100

This paper simulates a DNA molecule, as an information molecule, which contains a 10.2  $\mu\text{m}$  long nucleobase chain ( $L_m$ ). It is assumed to have 30,000 nucleobase pairs [25] and encode a message of 60,000 bits. The length of each molecular packet ( $L_p$ ) is calculated as follows:

$$L_p = L_m/n + L_h \quad (2)$$

$n$  denotes the number of divisions on an information molecule (i.e., the number of packets generated from the information molecule).  $L_m/n$  indicates the length of a payload (Fig. 2).  $L_h$  denotes the length of a header. 60 nucleobase pairs (120 bits) are allocated for a header in this paper ( $L_h = 0.0204 \mu\text{m}$ ).

The diffusion coefficient  $D$  and the radius  $R$  of a molecular packet are derived from the following equations [25].

$$D = \alpha L_p^{-\beta} \quad (3)$$

$$R = \gamma/D \quad (4)$$

Experimentally obtained values are used for  $\alpha$ ,  $\beta$  and  $\gamma$  [25]:  $\alpha = 2.8$ ,  $\beta = 0.6$  and  $\gamma = 3.4$ .

Figs. 4 and 5 show how Tx-to-Rx distance ( $d$ ), parity code rate (PCR) and packetization degree ( $n$ , i.e., the number of molecular packets) impact communication latency of a single information molecule to arrive at the Rx. When  $n = 1$ , an information molecule is not packetized. It appends a header to its payload (message) and travels to the Rx. When  $n > 1$ , an information molecule is packetized. Each packet appends a header its payload and travels to the Rx (Fig. 2). When PCR = 0, erasure coding is not performed. In this paper, latency indicates the interval between the time when a packet leaves the Tx and the time when the Rx reassembles a transmitted message by receiving a necessary set of packets.

In comparison of the two cases where an information molecule is fragmented to 10 and 100 packets ( $n = 10$  and  $n = 100$ ), both median and average latency generally improve as the degree of packetization ( $n$ ) increases. For example, when  $d = 30 \mu\text{m}$  and PCR = 0, average latency decreases by 8% as  $n$  increases from 10 to 100. When  $d = 90$  and PCR = 10, average latency decreases by 14% as  $n$

increases from 10 to 100. These results confirm that smaller/shorter DNA molecules diffuse faster than larger/longer ones.

Figs. 4 and 5 illustrate that both median and average latency improve as PCR increases. When the degree of packetization is 10 ( $n = 10$ ), average latency decreases by 45% as PCR increases from 0% to 50% ( $d = 90 \mu\text{m}$ ). When  $n = 100$ , it decreases by 46% as PCR increases from 0% to 50% ( $d = 90 \mu\text{m}$ ). These results demonstrate that the proposed protocol is robust against packet losses and improves communication latency.

Compared to the case where an information molecule is transmitted with packetization disabled ( $n = 1$  and PCR = 0), the proposed protocol decreases average latency by 19% and 27% when the degree of packetization is 10 and 100, respectively ( $d = 90$  and PCR = 50%). The proposed protocol successfully takes advantage of packetization and erasure coding to make improvements in latency performance.

Fig. 6 depicts the average number of collisions in a single simulation. This paper assumes that all molecular packets collide with each other. The number of collisions grows as the degree of packetization ( $n$ ) increases. However, it is very low even when  $n = 100$ . 100 molecular packets collide less than once on average in a single simulation.

Figs. 7 and 8 show how Tx-to-Rx distance ( $d$ ), parity code rate (PCR) and packetization degree ( $n$ ) impact communication latency with 10 duplicated information molecules. Figs. 10 and 11 show the latency with 100 duplicated information molecules. All duplicated molecules contain the same message. When packetization is enabled ( $n > 1$ ), each of the duplicated molecules is fragmented to packets. Latency indicates the interval between the time when a packet leaves the Tx and the time when the Rx reassembles at least one message.

Figs. 4, 5, 7, 8, 10 and 11 illustrate that duplication of molecules aids improving latency. Fig. 8 shows that the proposed protocol improves latency by 40% as it increases PCR from 0% to 50% when 10 duplicated information molecules are used ( $d = 90 \mu\text{m}$ ). Fig. 11 shows that the proposed protocol improves latency by 33% as it increases PCR from 0% to 50% when 100 duplicated molecules are used ( $d = 90 \mu\text{m}$ ). Similar to an observation in Figs. 5, Figs. 8 and 11 demonstrate that the proposed protocol is robust against packet losses and improves latency performance via packetization and erasure coding.

Another finding from Figs. 5, 8 and 11 is that the impacts of erasure coding on latency decreases as the number of duplicated molecules increases. Latency improvement due to the 0% to 50% increase of PCR decreases from 45% to 33% as the number of duplicated molecules grows from 1 to 100. This is caused by the increase in the number of collisions among molecular packets (Figs. 6, 9 and 12). Molecular packets collide with each other more than 1,200 times in a single simulation when 100 duplicated information molecules are used (Fig 12). In contrast, the number of collisions is less than one when a single information molecule is used (Fig. 6). Higher occurrence of collisions also makes latency performance comparable between the two cases: the case where no packetization is performed ( $n = 1$  and PCR = 0) and the case where 10 packets are generated but erasure coding is not performed ( $n = 10$  and PCR = 0) (Fig. 11). This observation is not obtained when the number of duplicated molecules are 1 and 10 (Figs. 5 and 8).

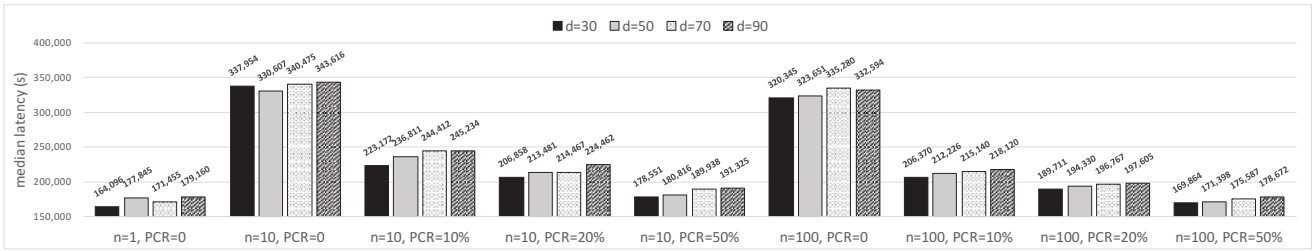

Figure 4: Median Communication Latency with a Single Information Molecule

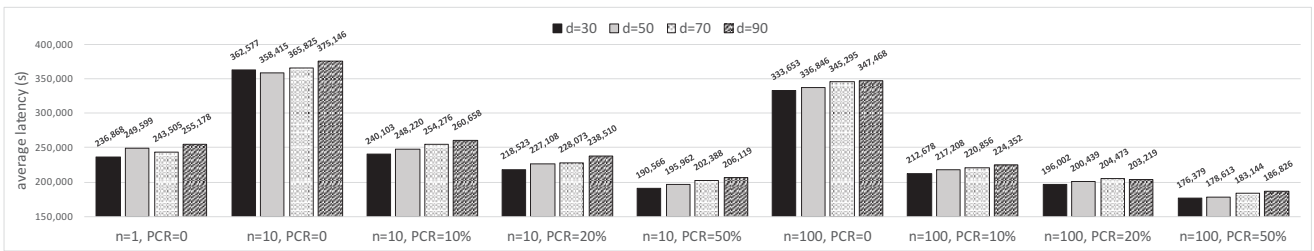

Figure 5: Average Communication Latency with a Single Information Molecule

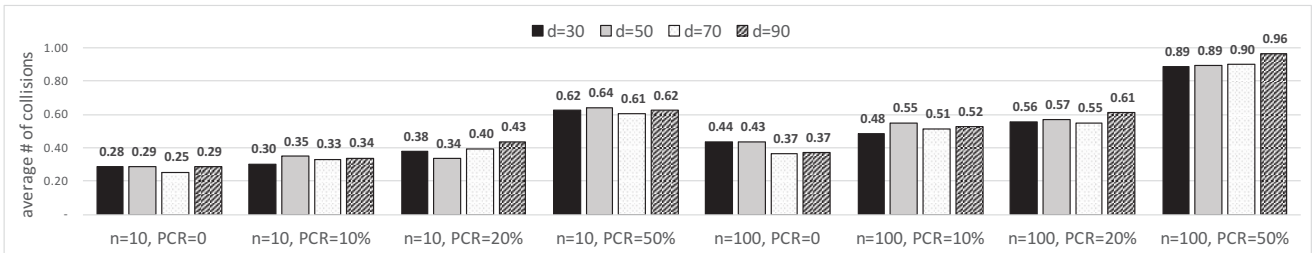

Figure 6: Average Number of Collisions among Molecular Packets Fragmented from a Single Info. Molecule

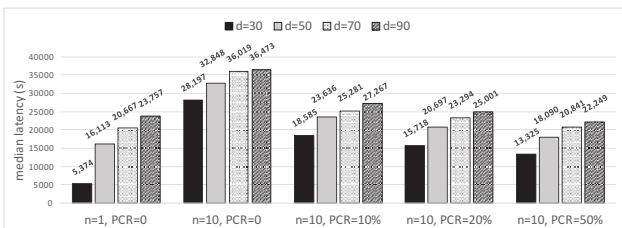

Figure 7: Median Latency with 10 Information Molecules

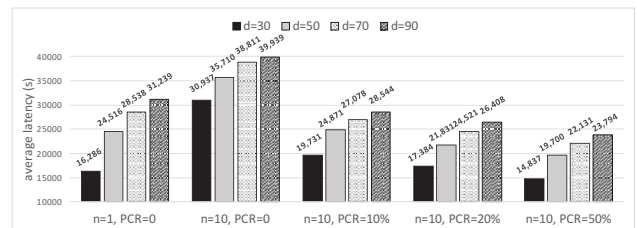

Figure 8: Average Latency with 10 Information Molecules

Table 2 shows how jitter of latency changes under different simulation settings. Jitter is computed as a standard deviation of latency results in 1,000 independent simulation runs. As illustrated in Table 2, the proposed protocol yields lower jitter as the degree of packetization ( $n$ ) and PCR increase. With a single information molecule, jitter decreases by 82% as  $n$  increases from 0 to 100 and PCR increases from 0% to 50% ( $d = 90\mu\text{m}$ ). With 10 and 100 duplicated molecules, jitter decreases by 68% and 71%, respectively, as  $n$  increases from 0 to 10 and PCR increases from 0% to 50% ( $d =$

$90\mu\text{m}$ ). Table 2 demonstrates that the proposed protocol successfully leverage packetization and erasure coding to substantially decrease latency jitter and make latency performance more predictable.

## 5 CONCLUSION

This paper investigates a protocol designed to enhance robustness of molecular communication against molecule losses. It performs forward error correction in which the transmitter bio-nanomachine

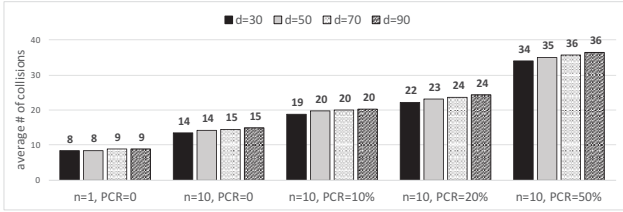

Figure 9: Average Number of Collisions among Molecular Packets Fragmented from 10 Information Molecules

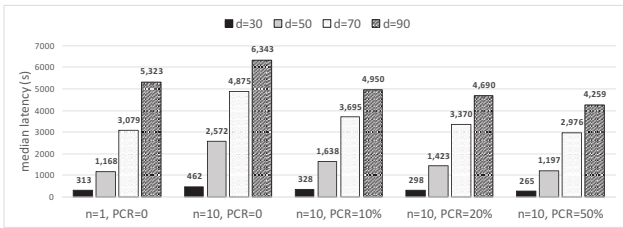

Figure 10: Median Latency with 100 Information Molecules

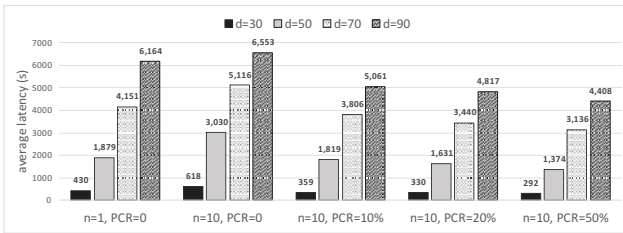

Figure 11: Average Latency with 100 Information Molecules

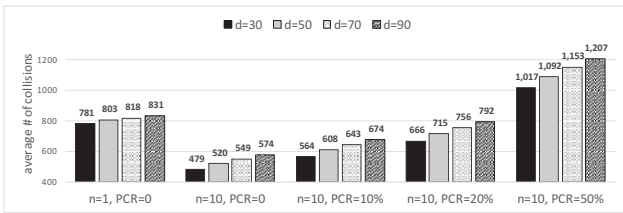

Figure 12: Average Number of Collisions among Molecular Packets Fragmented from 100 Information Molecules

(Tx) encodes molecules in a redundant manner with parity-check erasure coding and the receiver bio-nanomachine (Rx) recovers the information embedded in lost molecules. Simulation results demonstrate that the proposed protocol is robust against molecule losses and in turn improves communication performance such as latency and jitter. When communication distance is 90 μm between the Tx and the Rx, the proposed protocol improves latency by 45% and latency jitter by 82% through fragmenting an information molecule to 10 packets with the parity code rate of 10%.

Table 2: Jitter (Standard Deviation) of Latency Performance

# of duplicated molecules	Comm. distance (d)	Degree of packetization (n)	PCR	STDEV of latency		
1	30 μm	1	0	241,707		
		10	10 %	94,625		
		10	20 %	87,032		
		10	50 %	78,180		
		100	10 %	44,243		
		100	20 %	42,530		
		100	50 %	41,553		
		50 μm	1	0	229,289	
			10	10 %	89,588	
			10	20 %	84,164	
			10	50 %	78,714	
			100	10 %	43,901	
	100		20 %	43,757		
	70 μm	100	50 %	42,340		
		1	0	235,618		
		10	10 %	91,595		
		10	20 %	85,790		
		10	50 %	80,459		
		100	10 %	44,238		
	90 μm	100	20 %	44,412		
		100	50 %	42,539		
		1	0	252,221		
		10	10 %	95,671		
		10	20 %	92,029		
10		50 %	84,252			
10	30 μm	100	10 %	45,308		
		100	20 %	42,977		
		100	50 %	44,555		
		1	0	24,577		
		10	10 %	9,467		
		10	20 %	8,967		
		10	50 %	8,673		
		50 μm	1	0	27,031	
			10	10 %	9,052	
			10	20 %	8,223	
			10	50 %	7,810	
			70 μm	1	0	27,397
	10			10 %	9,518	
	10	20 %		8,223		
	10	50 %		7,810		
	90 μm	1		0	25,726	
		10		10 %	8,847	
		10	20 %	8,552		
		10	50 %	8,242		
		100	30 μm	1	0	508
				10	10 %	156
	10			20 %	142	
	10			50 %	114	
	50 μm			1	0	2107
10				10 %	845	
10				20 %	766	
10				50 %	711	
70 μm				1	0	3,262
				10	10 %	1,136
	10			20 %	1,047	
	10			50 %	1,033	
	90 μm		1	0	3,703	
			10	10 %	1,173	
10			20 %	1,135		
10			50 %	1,085		

REFERENCES

[1] I. Akyildiz, F. Brunetti, and C. Blazquez. 2008. Nanonetworks: a new communication paradigm. *Comput. Netw.* 52 (2008).

- [2] Chenyao Bai, Mark S Leeson, and Matthew David Higgins. 2014. Minimum energy channel codes for molecular communications. *Electronics Letters* 50, 23 (2014), 1669–1671.
- [3] C. Bai, M. S. Leeson, and M. D. Higgins. 2015. Performance of SW-ARQ in Bacterial Quorum Communications. *Nano Commun. Netw.* 6, 1 (2015).
- [4] P. Bogdan, G. Wei, and R. Marculescu. 2012. Modeling populations of micro-robots for biological applications. In *Proc. IEEE ICC Workshop on Molecular and Nano-scale Communications*.
- [5] H. O. Burton and D. D. Sullivan. 1972. Errors and Error Control. *Proc. of the IEE* 60, 11 (1972).
- [6] N. Farsad, A. Eckford, S. Hiyama, and Y. Moritani. 2011. A simple mathematical model for information rate of active transport molecular communication. In *IEEE INFOCOM Wksp Mol Nanos Comm*.
- [7] L. Felicetti, M. Femminella, G. Reali, T. Nakano, and A. V. Vasilakos. 2014. TCP-like molecular communications. *IEEE J. Sel. Area Comm.* 32, 12 (2014), 2354–2367.
- [8] R. A. Freitas. 2005. Current status of nanomedicine and medical nanorobotics. *J. Computational and Theoretical Nanoscience* 2, 1 (2005), 1–25.
- [9] T. Furubayashi, T. Nakano, A. Eckford, Y. Okaie, and T. Yomo. 2016. Packet Fragmentation and Reassembly in Molecular Communication. *IEEE Trans. NanoBiosci.* 15, 3 (2016).
- [10] S. Hiyama and Y. are. 2010. Molecular communication: harnessing biochemical materials to engineer biomimetic communication systems. *Nano Commun. Netws* 1, 1 (2010), 20–30.
- [11] Mark S Leeson and Matthew D Higgins. 2012. Error correction coding for molecular communications. In *2012 IEEE International Conference on Communications (ICC)*. IEEE, 6172–6176.
- [12] M. S. Leeson and M. D. Higgins. 2012. Forward error correction for molecular communications. *Nano Commun. Netws* 3, 3 (2012), 161–167.
- [13] Yi Lu, Matthew D Higgins, and Mark S Leeson. 2014. Diffusion based molecular communications system enhancement using high order hamming codes. In *Communication Systems, Networks & Digital Signal Processing (CSNDSP), 2014 9th International Symposium on*. IEEE, 438–442.
- [14] Yi Lu, Matthew D Higgins, and Mark S Leeson. 2015. Comparison of channel coding schemes for molecular communications systems. *IEEE Transactions on Communications* 63, 11 (2015), 3991–4001.
- [15] Yi Lu, Matthew D Higgins, and Mark S Leeson. 2015. Self-orthogonal convolutional codes (SOCCs) for diffusion-based molecular communication systems. In *2015 IEEE International Conference on Communications (ICC)*. IEEE, 1049–1053.
- [16] J. S. Mitzman, B. Morgan, T. M. Soro, J. Suzuki, and T. Nakano. 2015. A Feedback-based Molecular Communication Protocol for Noisy Intrabody Environments. In *17th IEEE Int'l Conference on E-health Networking Applications and Services*.
- [17] Michael John Moore and Tatsuya Suda. 2009. Molecular Communication: Modeling Noise Effects on Information Rate. *IEEE Trans. NanoBiosci.* 8, 2 (2009).
- [18] Y. Moritani, S. Hiyama, and T. Suda. 2006. Molecular Communication for Health Care Applications. In *IEEE Int'l Conf. Pervasive Comput. Commun. Workshops*.
- [19] T. Nakano, A. Eckford, and T. Haraguchi. 2013. *Molecular Communication*. Cambridge University Press.
- [20] T. Nakano, M. Moore, F. Wei, A. V. Vasilakos, and J. W. Shuai. 2012. Molecular communication and networking: opportunities and challenges. *IEEE Trans. NanoBiosci.* 11, 2 (2012), 135–148.
- [21] T. Nakano, Y. Okaie, and A. V. Vasilakos. 2013. Transmission Rate Control for Molecular Communication among Biological Nanomachines. *IEEE J. Sel. Area Comm.* 31, 12 (2013), 835–846.
- [22] Yutaka Okaie, Tadashi Nakano, Takahiro Hara, and Shojiro Nishio. 2013. Single Target Tracking in Bionanosensor Networks: Preliminary Simulation Results. In *Proc. Int'l Conf. on Body Area Networks*.
- [23] M. E. Ortiz and D. Endy. 2012. Engineered cell-cell communication via DNA messaging. *J. Biol. Eng.* 6, 16 (2012).
- [24] M. Pierobon and I. F. Akyildiz. 2011. Diffusion-based noise analysis for molecular communication in nanonetworks. *IEEE Trans. Signal Process.* 59, 6 (2011).
- [25] D. E. Smith, T. T. Perkins, and S. Chu. 1996. Dynamical Scaling of DNA Diffusion Coefficients. *Macromolecules* 29 (1996).
- [26] K. V. Srinivas, R. S. Adve, and A. W. Eckford. 2012. Molecular communication in fluid media: The additive inverse gaussian noise channel. *IEEE Trans. Inf. Theory* 58, 7 (2012).
- [27] T. Suda, M. Moore, T. Nakano, R. Egashira, and A. Enomoto. 2005. Exploratory research on molecular communication between nanomachines. In *Proc. ACM Genetic and Evol. Computat. Conference*.
- [28] J. Suzuki, D. H. Phan, and H. Budiman. 2014. A Nonparametric Stochastic Optimizer for TDMA-Based Neuronal Signaling. *IEEE Trans. NanoBioscience* 13, 3 (2014), 244–254.
- [29] R. D. Vale, T. Funatsu, D. W. Pierce, L. Romberg, Y. Harada, and T. Yanagida. 1996. Direct Observation of Single Kinesin Molecules Moving along Microtubules. *Nature* 380 (1996).
- [30] X. Wang, M. D. Higgins, and M. S. Leeson. 2014. Simulating the Performance of SW-ARQ Schemes within Molecular Communications. *Simulation Modelling Practice and Theory* 42 (2014).