

# Future Internet Elements: Cognition and Self-management Design Issues

A. Kousaridas, C. Polychronopoulos, N. Alonistioti  
Department of Informatics & Telecommunications, University of Athens, 302107275867  
akousar@di.uoa.gr

A. Marikar, J. Mödeker  
Fraunhofer FOKUS Competence Center Network Research, Sankt Augustin, Germany +49 2241142795  
achim.marikar@fokus.fraunhofer.de

A. Mihailovic  
Centre for Telecommunications Research, King's College London, +4478481853,  
andrej.mihailovic@kcl.ac.uk

G. Agapiou, I. Chochliouros, G. Heliotis  
Hellenic Telecommunications Organization S.A. (O.T.E. S.A.), Division of Labs & New Technologies +302106114663  
gagapiou@oteresearch.gr

## ABSTRACT

The scope of this paper is to introduce an innovative paradigm for cognitive self-managed elements of the Future Internet. The present Internet model is based on clear separation of concerns between protocol layers, with intelligence moved to the edges, and with the existent protocol pool targeting user and control plane operations with less emphasis on management tasks. Future Internet shall be engineered based on cognitive behavior with a high degree of autonomy, by proposing the operation of self-managed Future Internet elements around a novel hierarchical feedback-control cycle. The concepts are based on a hierarchical Distributed Cognitive cycle for System & Network Management (DC-SNM) which aims at facilitating the promotion of distributed management. The management approach encompasses a hierarchical distribution of cognitive cycles, breaking down the execution and decision making levels to (autonomic) network elements, network domain types and up to the service provider realm in order to address management, dynamic organization and (re)configuration of future internet elements.

## Categories and Subject Descriptors

C.2.1 [Computer-Communications Networks]: Network Architecture and Design

## Keywords

Cognitive Networks, Future Internet, Self-management.

## 1. INTRODUCTION

The technological progress of the last decades will continue to drive the usage of the Internet but, in parallel, it led current Internet infrastructure to its design limits. Current internet is divided into thousands of inter-dependent systems that are managed by a single network operator, while common address space and routing algorithms are the main mechanisms that allow systems' interaction and cooperation.

Permission to make digital or hard copies of all or part of this work for personal or classroom use is granted without fee provided that copies are not made or distributed for profit or commercial advantage and that copies bear this notice and the full citation on the first page. To copy otherwise, or republish, to post on servers or to redistribute to lists, requires prior specific permission and/or a fee.

*Autonomics* September 23-25, Turin, Italy  
Copyright 2008 ICST xxx-xxx-xx-xxxx-x.

The deployment of advanced services and the introduced mobility have increased the demand for a highly scalable, reconfigurable and dynamically service provisioning network infrastructure and has placed skepticism to operators to reassess the fixed and predictable pre-assigned parameters and structures in the network. The various requirements of the new services (e.g., traffic increase) make the prediction and planning difficult and put a lot of challenges to the operators in terms of expanding and managing the network.

The area of Future Internet is considered as a representative example of a complex adaptive organization, where the involved partners have conflicting goals and tension to maximize their gains [3]. This evolution renders imperative the need for adaptable and scalable systems that operate in unpredictable environments, having self-management features and the ability to handle complexity [5]. There is a need for new ways to organize, control and structure communication systems, according to new management schemes and networking techniques without neglecting the advantages of current Internet. Future Internet should be open for further and continuous improvement, without the necessity of another disruptive modification in the future.

The introduction of cognition to Future Internet elements is the main mechanism that is discussed in this paper so as to improve their performance by providing them the self-management capability. A conceptual architecture is described in order to form synergies, by decomposing management at various scales of a communication system. Furthermore, this paper proposes to split the functions of nowadays protocols (e.g., TCP), into functional protocol elements, and use these features (e.g., flow control, ARQ and congestion control) in independent combinations, according to the requirements of the application or network environment.

The remainder of this paper is organized as follows: The Future Internet vision and the how Self-NET face the emerging requirements are outlined in section 2. The key design principles of Self-NET and their application for synergies among network elements and for dynamic protocol composition are presented in section 3. The assessment of the proposed functionalities from network operators and end-users point of view, are outlined in section 4. Finally, conclusions are drawn in section 5.

## 2. FUTURE INTERNET VISION

Formulating the vision of evolution of the current Internet model and capabilities requires summarizing and formulating the vast space of potential advancements of technologies and functionalities of the Internet.

The requirements for such advancements of the current Internet come from various strategic drivers in terms of the services and applications that will be accommodated in the future, the use and adaptation of the emerging technical capabilities (either in terms of the capabilities of system elements or the collective powers of network segments) and various commercial considerations.

Self-NET introduces and develops new capabilities of systems in terms of the self-management features and cognitive capabilities. In parallel, Self-NET has accepted a vision for Future Internet expressed in the key challenges that are adopted from the European initiative on topics of Internet evolution [1]:

1. Explicit protocol design for a mobile wireless world requests “mechanisms which allow to shield some of wireless channels constraints from the behavior of the higher layers’ Post-IP protocols”.
2. Integrated Functional Design calls for a consideration of Mobility Management, QoS, and Security “also in a modular way”.
3. Alternative Stacks requests cross-layer design to increase performance and efficiency.
4. Data-aware network equipment states that “smart data manipulation functions should be distributed down to the appropriate border router”.
5. Handling service and network complexity states that “network capabilities and data transfer requirements of each service should be taken into account together, so that network entities decide in a clever way the path followed based on the capabilities of the underlying technologies, the characteristics of the information being transferred, and the preferences of the user”.

Self-NET has created a number of scenarios and use-cases that provide a methodology of explaining, validating and developing the synergy between the above Future Internet challenges and self-management potentials in networks. Some initial observations here are related to the general manner in which Self-NET systems address the challenges. Regarding the above challenges 1, Self-NET introduces functional modules that handle specific capabilities of each element in the network (e.g. in differentiating between packet loss due to congestion and/or bit-errors). Then, the functional modules that Self-NET will develop will tackle challenge 2. Self-NET uses a different approach of dynamic composition of functional modules, overcoming the static protocol stack design and providing a higher level of flexibility (challenge 3). For achieving a degree of data-aware equipment Self-NET meets the challenge 4 with its functional modules, that will provide, for example, a session-layer functionality such as content adaptation through a dynamically composed protocol and may be located (and even re-located) on any network element that is capable for such a service provision. Finally, service and network complexities (challenge 5) will be handled by developing component on level of networks that are capable of analysis and learning operational aspects of systems scattered over time and also self-management capability of network elements will handle some inducers of network complexity.

Functionalities that tackle some of the listed Future Internet challenges will be integrated with self-managed and cognitive capabilities of individual or collective network elements. Such a system developed by Self-NET will realize various introduced novel scenarios of Internet and will then accordingly meet the

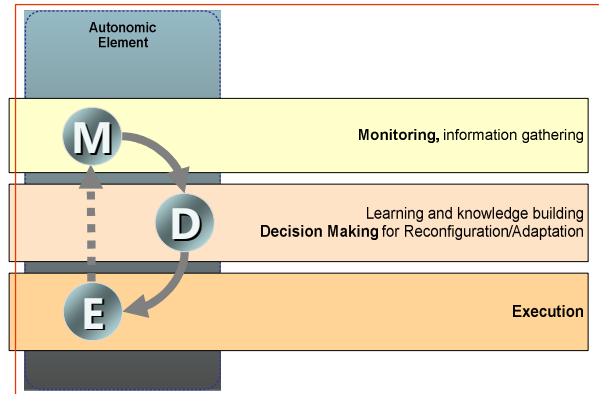

**Figure 1 Generic cognitive cycle model.**

objective expressed in Future Internet challenges. Hence, Self-NET aims to integrate the self-management and cognition features and the inevitable part of Future Internet evolution.

### 3. Self-NET DESIGN PRINCIPLES

Self-NET design principles are based on high autonomy of network elements in order to allow distributed management, fast decisions, and continuous local optimization. Moreover, the overall design follows the paradigms of self-awareness, self-management and self-optimization and the distributed and layered Cognitive cycle (Monitoring-Decision Making-Execution). The Generic Cognitive Cycle model, as it is depicted in Figure 1, is envisaged to be in the heart of Future Internet Elements. A Future Internet Element may be a network element (e.g., router, base station, and mobile device), a network manager, or any software element that lies at the service layer. Future Internet Elements, with cognition embedded, will have a process for monitoring and perceiving internal and environmental conditions, and then planning, deciding and adapting (self-reconfiguring) on these conditions. Such an element is able to learn from these adaptations (reconfigurations) and use them for future decision making, while taking into account end-to-end goals.

The three distinct phases of the Generic Cognitive Cycle Model are the following:

- **Monitoring** process involves gathering of information about the environment and the internal state of a Future Internet Element.
- **Decision Making** process includes learning, knowledge building and decision making for reconfiguration and adaptation, utilizing the developed knowledge model and situation awareness.
- **Execution** process involves (self-) reconfiguration, software-component replacement or re-organization and optimisation actions.

The Monitoring process receives, internally or externally, information about the effectiveness of the Execution process that took place, after the last decision. The Execution and Monitoring interaction is considered as an indirect feedback, useful for system’s learning process and, in sequel, for the update of the knowledge model.

Self-NET proposes a Distributed Cognitive cycle for System & Network *Management* (DC-SNM) that will facilitate the promotion of distributed/decentralised management over a

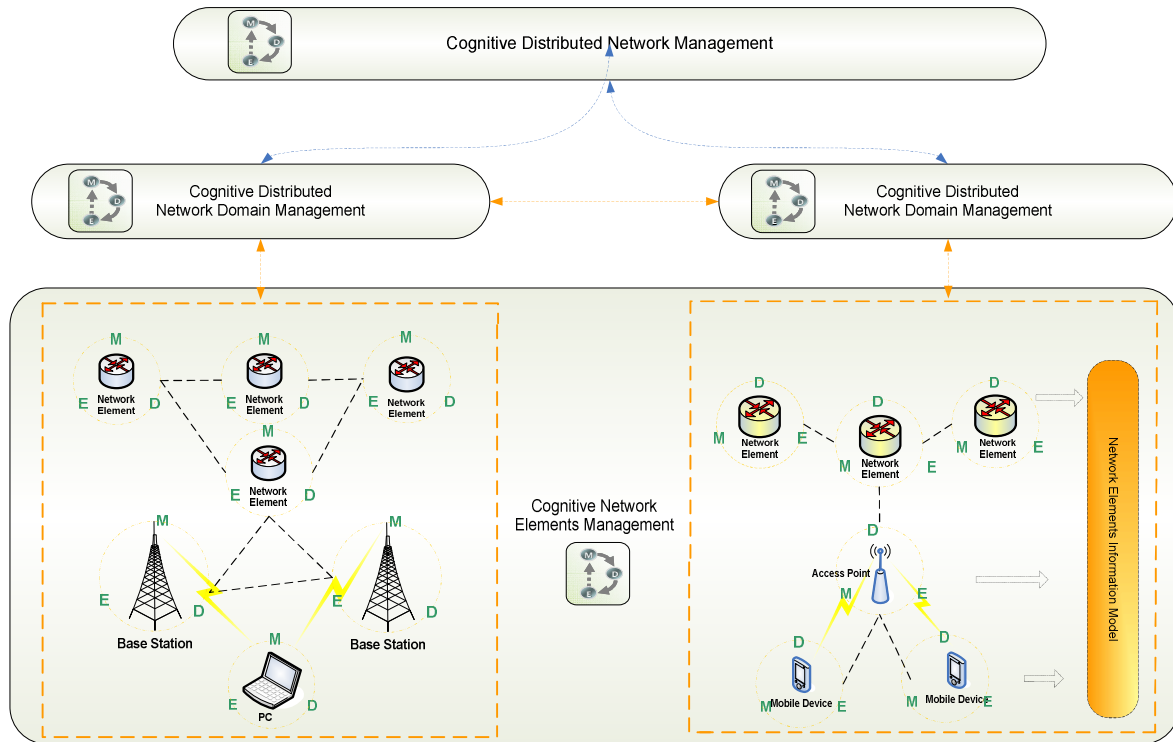

**Figure 2 Distributed cognitive cycle for system & network management (DC-SNM).**

hierarchical distribution of management and (re)configuration making levels to (a) (autonomic) network elements, then (b) to network domain types and (c) up to the service provider realm. Hence, this will set the scene for one of the major design principles in Self-NET, which is high autonomy of network elements with cognitive capabilities aimed at fast localised (re)configuration actions and decision making. Such a distribution brings about the intriguing issue of orchestrating the cognitive cycles (M-D-E) of Monitoring, Decision Making and Executions at higher levels of the management distribution. Self-NET tackles this by involving management processes at network domain levels and service provider level applying the management notions of self-awareness, self-management and self-optimisation in the collective and targeted management of processes.

The logic behind the introduction of the DC-SNM is to serve as the conceptual template of introducing the Self-NET advances in the overall system as well as a network management instrument. Hence, it is a formulated tool for addressing the complexity and capabilities of networks, services and management elements and their roles as providers of new paradigms that are emerging in the evolution of needs and mechanisms for Future Internet, service and network infrastructures in general. The Distributed Cognitive cycle for System & Network Management can be used as the guiding framework for constricting the architectural and functional features in relevant deployment scenarios.

The decomposition of network management into responsibility areas will provide the principle on which universal management architecture will be developed having as a main goal the efficient handling of complexity towards Future Internet environments. Such a decomposition combined with the introduction of cognitive functionalities at all layers will allow decisions and configurations at shorter time-scales. Each element at the

identified layers has embedded cognitive cycle functionalities and also the ability to manage itself and make local decisions. For an efficient and scalable network management, where various stakeholders participate, a distributed approach is adopted. Dynamic network (re)-configuration in many cases is based on cooperative decision of various Future Internet Elements and distributed network management service components. Hints and requests/recommendations are exchanged among the layers, in order to indicate a new situation or an action for execution. The automated and dynamic incorporation of various layers requirements (e.g., SLAs) into the management aspects provides also novel features to network management capabilities. Moreover, the resolution of conflicting requests will be an issue of situation awareness and elements' domain policy prioritisation.

Based on this concept, new techniques to organize and control communications systems are proposed, focusing on: Network management at various levels of the communication systems and dynamic protocol composition of functional modules.

### 3.1 Synergies of Network Elements

Future Internet environment is envisaged in a multi-operator and multi-RAT area populated with several multi-vendor elements. Future communication systems consist of heterogeneous wireless and wired communication technologies and include various computing and networking elements. The high heterogeneity and mobility levels of the involved elements in the dynamic communication ecosystem have led to complexity increase as well as to continuously change of the available resources in the corresponding area. On the other hand there are more opportunities from which the elements could benefit.

Current Internet design does not focus on network management aspects while the commonly adopted protocols and mechanisms

are mainly centralized and require human intervention [7], [11]. Self-management capabilities are necessary because of the parallel operation of several network infrastructures and the arising need to automate network management extending the current centralized paradigms. There is the need for mechanisms to manage the complexity and the opportunities that arise, by using new ways to control and organize communication systems.

Synergies describe the self-organizing formation of multiple cognitive elements that are acting locally together in open systems, in a collaborative manner, towards a common end, and for a common global purpose [9]. Autonomic elements (AE) structure, dynamical hierarchies, self-similarity, and openness to the environment are the key features for the design of the synergetic architecture. Cognitive mechanisms embedded at each network element enable its autonomous hypostasis (i.e. autonomic element). Cognitive network elements collective interaction leads to the formation of higher level autonomic element structures. The autonomic element paradigm has been adopted in order to a) develop intrinsic adaptable communication systems, b) to introduce cognitive mechanisms, and c) to decompose functionalities or solutions. Individual network elements or clusters of network elements may represent an A structure.

Autonomic elements structure is formed using the dynamical hierarchies concept. Decomposition and dynamical hierarchies are fundamental characteristics of natural systems, which exhibit high degree of organization that is based on the hierarchy of the structural levels where each level builds the next one, enabling scalability and complexity management. Dynamical hierarchies of autonomic elements are structured using the concept of self-similarity. Each AE is much like the whole, but in a smaller scale as regards the structural characteristics and interaction principles, facilitating AEs dynamic re-organization. Finally, openness allows efficient collaboration and self-organization of autonomic elements, forming more composite structures.

The fundamental parts of each AE structure are: a) the *Element Services*, the core part of the AE, which implements its functionality, the process that it executes and the role that the specific element has in the structure that it participates, b) the *Cognition, Syllogism and Planning (COSYP)*, which provides the element intelligence through reasoning and interaction, as well as the balance between proactive and reactive adaptive behavior on the process that the element services part executes, and c) the interfaces for AE interactions. Each AE, regardless its level (e.g., II in Figure 3) has developed COSYP functionality, which as a whole is emergent by the corresponding COSYP interaction of the underlying AE structures:

- a.  $AE_{II} = \{COSYP_I, AE-Service_I\}$
- b.  $AE-Service_I = \{AE-Service_{I-MD D}, AE-Service_{I-MD E}, AE-Service_{I-MD F}\}$
- c.  $COSYP_{II} = \{COSYP_{I-MD D}, COSYP_{I-MD E}, COSYP_{I-MD F}\}$
- d. (elementary)  $AE_{I-MD D} = \{COSYP_{I-MD D}, AE-Service_{I-MD D}\}$

This type of organization, using dynamic re-organizing autonomic elements has been selected in order to decompose management by solving locally problems that may arise and improve locally the behavior of specific areas, taking also into account common global purposes. Synergies among autonomic elements structures include the cooperative interaction of the underlying autonomic

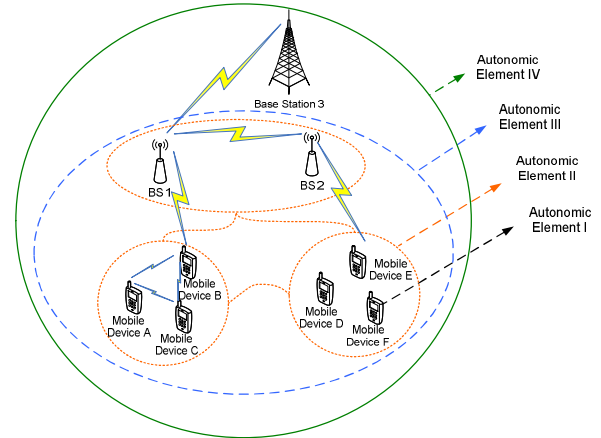

**Figure 3** Dynamical hierarchies of self-similar autonomic elements.

elements for any phase of the feedback cognitive cycle (Monitoring, Decision making, Execution) in order to solve networking problems (e.g., Topology optimization, taking into account for examples global throughput constraints and specific local requirements).

### 3.2 Dynamic Protocol Composition

TCP and UDP are the mainly used transport protocols in the current Internet for the developers of an application or for a protocol residing higher than the transport layer. However, modern applications have not been in the focus of the developers of these protocols. Time-critical applications like Voice over IP (VoIP) were not available those days. A lot of new applications like online-games, videoconferencing and IPTV also do not work as well with TCP and UDP as they should. Issues like mobility have not been regarded when specifying the common transport protocols. On top of that, the original congestion and flow control features do not support the fast connections available today, especially if the delay is too high to work with the limited window-size.

Due to the inconvenience using TCP or UDP as the transport protocol for modern, time critical protocols and applications, a lot of work has to be done in order to fit the transport protocols to modern applications. The Stream Control Transmission Protocol (SCTP) [10] is a modern replacement for TCP. It supports acknowledged and error-free transfer of data like TCP does. SCTP can make use of selective acknowledgments (SACK) and supports multihoming, heartbeats and a modernized congestion control. Because it supports a 4-way-handshake, denial of service attacks like SYN-flooding is not possible.

The Datagram Congestion Control Protocol (DCCP) [4] is the modern complement to UDP. It is used for transmitting unacknowledged messages. Unlike UDP it offers congestion control which is important to avoid paralyzing links with a huge amount of data for videostreaming or other real time data. Other approaches try to place more intelligence into the network [2]. Protocols like Split-TCP [8] and Semi-Split-TCP [6] make use of routers with enhanced possibilities. By using a link based ARQ it is possible to shorten the time for retransmissions. This is necessary for real time applications to avoid a high jitter caused by repeated packets. Figure 4 shows the time difference between a retransmitted TCP-packet and a Split- TCP-packet.

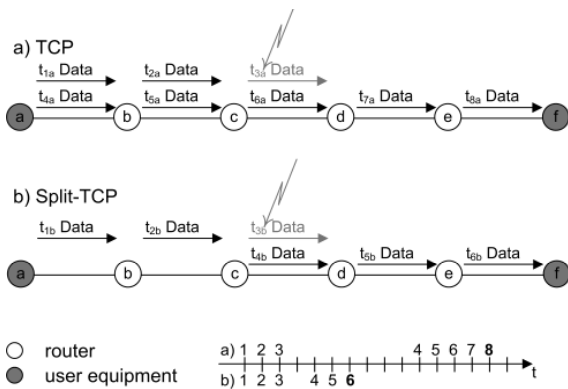

**Figure 4: A packet is lost between router c and d. The duration  $t_{8a}$  until the retransmitted packet reaches the destination with TCP is much longer than  $t_{6b}$  with Split-TCP.**

These protocols solve a lot of problems caused by TCP and UDP, but each protocol is only solving some specific problems. It is still up to the developer of an application to decide which protocol to use. Modern applications' varying requirements make it impossible to use a protocol which fits exactly to the application.

To satisfy the requirements of modern applications and services types, it is necessary to split functions of current protocols into functional protocol elements (FPE), (e.g., TCP) like Flow Control, automatic repeat request (ARQ) and Congestion Control and use the features of all these protocols in an independent combination. All features like Encryption, Forwarding, FEC, ARQ, Congestion Control, QoS etc. can be combined depending on application or network and deployed functionality might change at each hop. It is not sufficient to be able to compose all needed FPEs to a customized protocol. It must also be possible to dynamically change some features on the way through the network. This means that FPE enabled routers based on the cognitive cycle can add or remove a feature if it increases the quality of a stream, a link or a complete part of a network. A possible modification of the protocol components is shown in Figure 5.

#### 4. ASSESSMENT DISCUSSION OF THE PROPOSED FUNCTIONAL FEATURES

The main driver, advantages and the gain that derives from the above concepts on specific mechanisms are described in this section. The benefits of the introduced Self-NET functionalities in the Internet architectures for the operators include, inter-alia:

a) *Automatic planning and reduction of management time of complex network parameters and structures*

The current and future anticipated high proliferation of different services that a communications network should support, places a very challenging issue for network operators to solve, and makes the tasks of adjusting network performance and optimizing network resource usage as critically important.

Daily (human) network manager activities consist of numerous tedious and time-consuming tasks in order to ensure that the network delivers the desired services to its users. In many cases, the network operator is obliged to search through vast amounts of monitoring data to find any "inconveniences" to his network behavior and to ensure a proper delivery of services. Embedding self-management functionalities in future network elements and

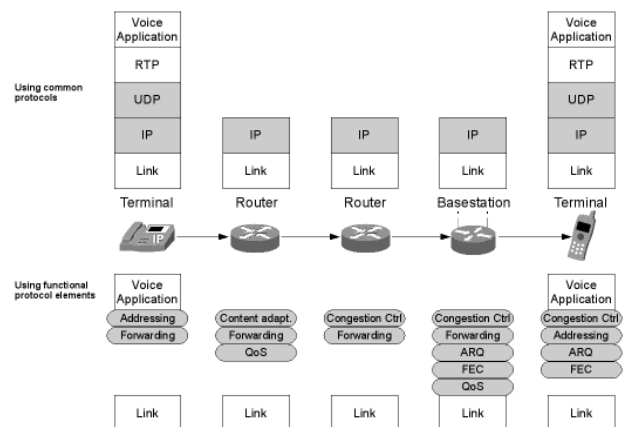

**Figure 5: The used features can be changed on each hop.**

introducing cognition in the various network levels (e.g., network elements, network compartments, and network domains) can automate the detection of unusual (or undesirable) behavior, the isolation of their sources, the diagnosis of the corresponding fault(s) and the expected repair of the problem. In some cases, it is also desirable to actually predict irregular events (like faults or intrusions) and to react, accordingly, in due time, as the vulnerability of network elements remains a critical issue for network operators. Applying self-aware techniques in a network environment can thus ease network composition and planning procedures and ensure automatic adaptation of networks and services to the current capabilities of the network components.

b) *Operational costs reduction*

Any infrastructure capable of performing automated operational tasks for the aim of optimization of both network efficiency and service quality, can so contribute to the objective of reducing actual network operational expenditures (OPEX). The option for automating several procedures can be remarkably beneficial to network operators as it facilitates various complex (and resource-consuming) processes, currently deployed at a large time scale and requiring significant human intervention. This also enables a more affordable and simpler network deployment.

By applying self-management techniques aiming at optimizing the network in terms of coverage, capacity, performance etc., operators can decrease their operational expenditures by reducing the manual effort required to operate a network and can utilize their network elements/resources more efficiently. Furthermore, such techniques can also simplify network maintenance and fault management, by reducing related costs, as well.

c) *Easy adaptation of networks (e.g., in new traffic models and schemes)*

Traditional traffic management of a communications network usually relies on integrated and centrally coordinated deployment of measures and rules, in response to the current network operating state and/or in anticipation of future needs and traffic conditions. Traffic management configuration of large wireless networks that consist of multiple, distributed network elements of varying technologies is challenging, time-consuming, prone to possible errors and requires highly expensive control & management equipment from any operator. Even when it is initially deployed, it requires continuous upgrades and related modifications so that to provide a uniform & transparent service

environment, to sustain high quality of service, to recover from faults and to maximize the overall network performance, especially when congestion happens.

To enable effective and efficient networking under highly demanding conditions, a continuous network management (proactively and reactively adapted to the network dynamics) is necessary. Instead of using manual techniques, a fully automated, transparent and intelligent traffic management functionality can be much more beneficial. The suggested Self-Net infrastructure can so be used to provide efficient real-time traffic management in a large wireless network, maximizing network performance and dramatically decreasing human intervention. Particular application areas can cover cases of traffic congestion, network attachments, link failures, performance degradation, mobility issues, multi-service delivery enhancements and involve intelligent autonomic congestion management and traffic routing, dynamic bandwidth allocation and dynamic spectrum re-allocation.

The continuity of service availability influences directly the technical approach of service realization and is an important parameter affecting the planning of the network, so the latter should have the appropriate techniques to “adapt itself” to an essential (occasionally prescribed) functional state. The network should be able to gather information about various entities and modules, detect their operational state and react to any deviations from the proposed desired operational state.

The application of self-aware mechanisms can lead to network performance optimization in terms of coverage and capacity, optimization of QoS delivered to the end user, reduction of human intervention in terms of determining the most appropriate course of actions and proceeding to the implementation of optimization activities.

Some among the essential benefits for the users are listed as follows:

a) *Seamless experience to users in selecting a network in a dynamic and robust manner*

It is a matter of major importance, for the end users, to have access to a network providing coverage and services of high quality, on a real time basis. Self-management techniques imply decentralized monitoring and decision making procedures so that suitable optimization hints can be extracted in terms of determining the optimum course of actions in order to improve network performance and stability and guarantee service continuity to the users.

b) *Improved service provision and adaptability.*

Any dynamic detection of operational deficiencies or poor quality of services delivered to the end user, imply specific remediate actions to be performed, so that to compensate for the related identified problems. Improving the overall network quality, also increases subscribers’ satisfaction. The optimization of procedures in order to minimize (or even to “delete”) service failures and to ensure the continuity of service delivery in a network environment, is a matter of major importance for the user and the operator, in a competitive and liberalized telecommunications market. In this scope, for example, congestion management is a very frequent issue that network operators have to encounter, as it directly impacts the overall network performance and, correspondingly, affects customers’ experience and satisfaction.

## 5. CONCLUSIONS

The Future Internet vision, as articulated in the various research fora and technology platforms, is expected to have a great impact on the design of future network elements in terms of functional and protocol flexibility with the use of knowledge-based mechanisms standing in the heart of the proposed solutions. Self-NET tries to provide an answer to the Future Internet challenges by introducing a Distributed Cognitive cycle for System & Network Management, which augments the various levels of network management with high autonomy enabled by cognitive capabilities. In particular, the DC-SNM concept is utilized for mechanisms like synergies formation among network elements and dynamic protocol composition. The paper concludes with a discussion on the assessment of the significant benefits network operators expect from the application of the proposed solutions.

## 6. ACKNOWLEDGMENTS

This work was funded by the European Commission Seventh Framework Programme ICT-2008-224344 through the Self-NET Project (<https://www.ict-selfnet.eu>).

## 7. REFERENCES

- [1] F. Andersen, H. Berndt, H. Abramowicz, R. Tafazolli. Future Internet: from Mobile and Wireless Requirements Perspective. eMobility Technology Platform White Paper, 2007.
- [2] P. G. Bridges, G. T. Wong, M. Hiltunen, R. D. Schlichting, M. J. Barrick, A Configurable and Extensible Transport Protocol. IEEE/ACM Transactions on networking, 2007.
- [3] D. Clark, J. Wroclawski, K. Sollins, R. Braden. Tussle in Cyberspace: Defining Tomorrow’s Internet. IEEE/ACM Transactions on Networking, Vol. 13, No. 3, June 2005.
- [4] Datagram Congestion Control Protocol (DCCP). RFC4340, IETF, 2006
- [5] S. Dobson, et al. A survey of autonomic communications. ACM Transactions on Autonomous and Adaptive Systems (TAAS), vol. 1, Issue 2, pp. 223 – 259, 2006.
- [6] Xie Fei, Jiang Ning, Ho Yao, Hua Hua, Kien A. Semi-Split TCP: Maintaining End-to-End Semantics for Split TCP. IEEE Local Computer Networks, 2007.
- [7] D. Harrington, R. Presuhn, B. Wijnen. An Architecture for Describing Simple Network Management Protocol (SNMP) Management Frameworks, RFC 2571, IETF, 2002.
- [8] S. Kopparty, S.V. Krishnamurthy, M. Faloutsos, S.K. Tripathi. Split TCP for mobile ad hoc networks. IEEE Global Telecommunications Conference, 2002.
- [9] A. Kousaridas and N. Alonistioti. On a Synergetic Architecture for Cognitive Adaptive Behavior of Future Communication Systems. 2008 International Symposium on World of Wireless, Mobile and Multimedia Networks (WoWMoM), pp. 1-7, 2008.
- [10] R. Stewart, Stream Control Transmission Protocol (SCTP). RFC4960, IETF, 2007.
- [11] 3GPP TS 32.101. Telecommunication management; Principles and high level requirements. [http://www.3gpp.org/ftp/Specs/archive/32\\_series/32.101](http://www.3gpp.org/ftp/Specs/archive/32_series/32.101)