

# A comparison of 802.11a and 802.11p for V-to-I communication: a measurement study

Wei-Yen Lin, Mei-Wen Li, Kun-chan Lan, Chung-Hsien Hsu\*

Computer Science and Information Engineering  
No.1, University Road, Tainan City 701, Taiwan (R.O.C.)  
{q5697107, p78981304}@mail.ncku.edu.tw, klan@csie.ncku.edu.tw  
Information and Communications Research Laboratories\*  
Bldg. 14, 195, Sec. 4, Chung Hsing Rd., Chutung, Hsinchu, Taiwan. 31040.  
stanleyhsu@itri.org.tw

**Abstract.** 802.11p, also known as WAVE, is a standard protocol intended for future traffic systems in order to support safety and commercial non-safety applications for vehicular communication. 802.11p is modified from 802.11a, and both are based on OFDM. The main difference between 802.11a and 802.11p is that the latter is proposed to use 10 MHz frequency bandwidth (half of bandwidth of 802.11a) in order to make the signal more robust against fading and increase the tolerance for multipath propagation effects of signals in a vehicular environment. In this paper, we investigate the performance difference between 802.11a and 802.11p for Vehicle-to-Infrastructure communication through real-world experiments. We measure contact duration and losses of 802.11p and 802.11a in both LOS and NLOS environments. In addition, we investigate their throughput with different modulations over various distances between OBU and RSU to evaluate the feasibility of using rate adaptation for non-safety V-to-I applications.

**Keywords:** 802.11p, guard interval, multipath, modulation.

## 1 Introduction

To decrease the number of traffic accidents, the U.S. Federal Communication Commission (FCC) has allocated a 75MHz spectrum at 5.9GHz for vehicle-to-vehicle and vehicle-to-infrastructure communications. The proposed vehicular communication technology, known as the Dedicated Short Range Communication (DSRC), is currently being standardized by the IEEE [1, 2]. Many major car manufacturers have responded positively, and are actively working together in bringing this promising technology into reality [3, 4]. An IEEE 802.11 standard, called IEEE 802.11p [5], is designed as the basic model for DSRC, and can be used to provide safety and service applications for Intelligent Transportation Systems (ITS) in the vehicular environment.

ITS include telematics and all types of communications in vehicles, between vehicles (V-to-V), and between vehicles and fixed locations (V-to-I). In general, the various types of ITS rely on radio services for communication and use specialized

technologies [18]. DSRC is currently one of the most promising technologies related to automotive ITS.

There are two basic types of nodes in a DSRC (also called WAVE) networks: an On Board Unit (OBU) is located on vehicles and acts as an IEEE 802.11 station, while a Road Side Unit (RSU) is deployed on the road side and serves as an IEEE 802.11 access point. WAVE network can be operated in either infrastructure or ad-hoc modes. In the infrastructure mode, OBU accesses the network via WBSS (Wave Basic Service Set), which consists of OBUs and RSUs. The stations that create the WBSS to provide the service are called “providers,” while those joining the service are called “users”. WAVE is comprised of two protocol stacks: the standard Internet Protocol (IPv6) and the WAVE short message protocol (WSMP), as shown in Figure 1. WSMP allows applications to directly control physical layer characteristics used in transmitting the messages, e.g., channel number and transmitter power. WSMs (WAVE short messages) are delivered to the corresponding application at a destination based on the Provider Service Identifier (PSID) [6]. In this paper, we perform our experiments using WAVE short messages to send and receive packets.

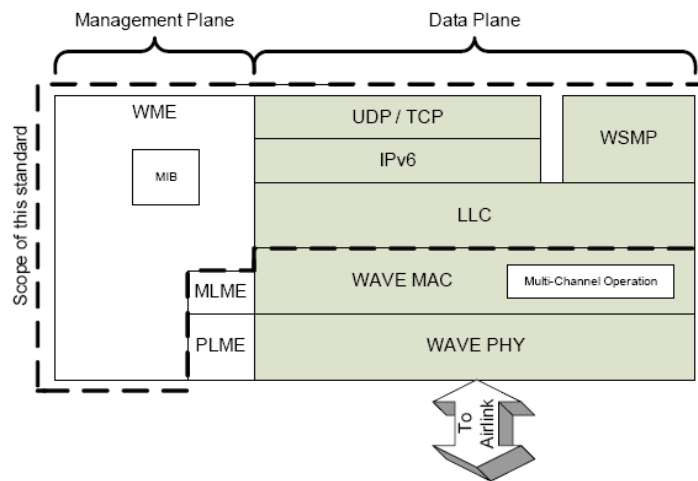

**Figure 1:** WAVE protocol stack. WAVE accommodates two protocol stacks: the standard Internet Protocol (IPv6) and the unique WAVE short message protocol (WSMP)

The performance of 802.11a for vehicular communication has been studied extensively in simulations as well as on various testbed. However, as far as we know, there very few studies have been performed to understand the performance of 802.11p in a real-life scenario. Theoretically, the PHY layer of IEEE 802.11p PHY is pretty similar to that of IEEE 802.11a. The important PHY parameters for both the protocols are listed in Table 1 [8, 9]. In this paper, we set out to answer the following question: How much better is 802.11p for V-to-I communication compared to 802.11a in a real-life situation? And does the performance of 802.11p match the expectations that people have for it?

**Table 1.** Comparison of the physical layer implementations used in IEEE 802.11a and IEEE 802.11p

Parameters	IEEE 802.11a	IEEE 802.11p half clocked mode	Changes
Bit rate (Mbit/s)	6, 9, 12, 18, 24, 36, 48, 54	3, 4.5, 6, 9, 12, 18, 24, 27	Half
Modulation mode	BPSK, QPSK, 16QAM, 64QAM	BPSK, QPSK, 16QAM, 64QAM	No change
Code rate	1/2, 2/3, 3/4	1/2, 2/3, 3/4	No change
Number of subcarriers	52	52	No change
Symbol duration	4 $\mu$ s	8 $\mu$ s	Double
Guard time	0.8 $\mu$ s	1.6 $\mu$ s	Double
FFT period	3.2 $\mu$ s	6.4 $\mu$ s	Double
Preamble duration	16 $\mu$ s	32 $\mu$ s	Double
Subcarrier spacing	0.3125 MHz	0.15625 MHz	Half

## 2 Related work

WAVE (Wireless Access in Vehicular Environments) or, 802.11p, is an IEEE standard which provides enhancements to the physical (PHY) and medium access control (MAC) layers of 802.11a for vehicular communication. Many studies have proposed different wireless technologies for vehicle communications based on existing standardized wireless technologies, such as Infrared, GSM, DSRC, Wi-Fi, Wi-Max, Bluetooth, RFID, for communication under one umbrella for ITS [10].

The V-to-I architecture allows vehicles to communicate with some roadway infrastructure and can enable many promising ITS applications. For example, the speed and location of a vehicle to be transmitted to a central server directly or indirectly connected to the road side unit. This server will track the speed and location of all vehicles and will aggregate this data for ITS applications, such as determining the fastest path from a vehicle's current location to its destination or identifying the location of an incident, among other applications [22]. There are also many applications that can be supported by a V-to-I communication network, such as web surfing, multimedia streaming, and real time car navigation. For example, some prior studies [23] have focused on the use of V-to-I for web applications.

There have been a lot of studies focusing on DSRC, but most of them have used simulations for their evaluations. [13] proposed a vehicle-to-infrastructure (V-to-I) communication solution by extending IEEE 802.11p. They introduced a collision-free MAC phase with an enhanced prioritization mechanism based on vehicle positions and the overall road traffic density, and evaluated their protocol's performance in Matlab. In [9, 12], the researchers used an NS-2 simulator to undertake a detailed simulation study of the performance of both DSRC and 802.11 for vehicular networks, and proposed a practical approach for IEEE 802.11 rate adaptation. In [14], an OMNeT++ simulator was used to evaluate the collision probability, throughput and delay of 802.11p. In [15], they used a QualNet simulator to compare two systems (WiMAX and 802.11p) for V-to-I communication under different vehicle speeds, traffic data rates, and network topologies.

To the best of the authors' knowledge, few DSRC testbeds have been implemented.

In [16], a GNURadio platform was used for the data transmission in a vehicular network. [10] implemented XBee/Zigbee OBE (on-board equipment) and RSE (road-side equipment) for vehicle communication (V-to-V and V-to-I), while in [17], they used an Aeroflex 3416 to collect measurement data. All of the above studies required an extra connection to a computer/laptop equipped GPS for their experiments. CAMP (Crash Avoidance Metrics Partnership) is a working group comprised of seven automotive companies for providing vehicle-based safety systems. [24] So far, their task is considering the crash imminent braking to develop and validate performance requirements and objective tests for imminent crash automatic braking systems. The test methods are evaluated with vehicle-to-vehicle crashes and vehicle-to-object crashes. Cohda Wireless [25] has completed more than 700 DSRC trials, for 15 distinct DSRC use-case scenarios, in the USA, Italy and Australia. Their V-to-I scenario was executed with the RSU mounted in closed intersections and open intersections while a car traveled at 60 km/h, through and beyond an intersection with buildings on all corners. They compared the performance of the Cohda Radio to radios using WiFi chipsets configured for DSRC operation from several different manufacturers. They showed that the connection provided by the radio using a WiFi chipset is limited in range and capacity for data to be transmitted, making it unattractive for multiple user access. In contrast, we performed our measurement to measure the contact duration with varying speed in fixed range to identify how fast 802.11p can connect to roadside station. In this work, we use an IWCU (ITRI WAVE/DSRC Communications Unit) [11] made by Industrial Technology Research Institute (ITRI), which is loaded with a Linux kernel 2.6.30 built-in processor and has 16MB Flash and 64MB SDRAM for system memory. It implements IEEE 802.11p standard and operates at 5.85-5.925 GHz with built-in GPS capability.

Finally, rate adaptation is one of the key mechanisms at the link layer that can be used to improve network performance. Several rate adaptation algorithms have been proposed in the literature. However, all the existing work in rate adaptation is all based on WiFi. In [12], a rate adaptation algorithm based on 802.11a was evaluated in an NS2 simulation for a single hop topology. [19] performed a series of 802.11a-based outdoor experiments to compare the existing rate adaptation algorithms. In [20], the authors collected measurements from their 802.11-based mesh network to understand the correlation between SNR and distance, given the same modulation. In this work, we set out to examine the performance of 802.11p when different modulations are used. Specifically, we measure the throughput of an 802.11p link when different modulations are used at different distances.

### **3 Trace collection**

In this paper, we use the IWCU from ITRI. The IWCU serial products are meant to provide V-to-V and V-to-I communication enabling ITS applications ranging from safety to infotainment, as shown in Table 2 [11]. We look at three performance metrics of 802.11p in our experiments: contact duration, loss distribution and throughput when different modulations are used. The scenarios and parameter settings are explained in the following three subsections.

**Table 2.** IWCU Specifications

Component	RSU	OBU
Processor	IXP422 266MHz	
Processing power	266MIPS	
System Memory	16MB Flash, 64MB SDRAM	
DSRC Radio	IEEE 802.11p 5.85-5.925 GHz, 12dBm TX, -90 dBm RX Sensitivity	
Channel Width	10MHz/20MHz	
Antenna	5.9GHz, 2×5dBi	
Ethernet	10/100 Mbps (RJ-45) port × 1 with Auto Uplink™, Full-duplex	
GPS	Receiver Type: 50 Channels(GPS L1 frequency, C/A Code, GALILEO Open Service L1 frequency) A-GPS support · Active antenna ×1 Sensitivity: -160 dBm (Tracking & Navigation)	
Dimension	300 × 250 × 80 mm	193 × 150 × 47 mm
Pre-Standards Compliance	IEEE 802.11p D6.0, IEEE 1609.3, IEEE 1609.4	
OS	Linux, kernel 2.6.28	
System Services	FTP, SSH, Telnet, HTTP	

### 3.1 Contact duration

In this experiment, we measure how long a car can maintain a connection with the road-side unit (RSU) when it passes the unit. We define the contact duration as the longest interval between when the first packet was sent by the car and the time when the last packet was received by the road-side unit. We start the car at a position where it is out of the radio range of RSU, gradually increasing the car's speed and achieving the desired speed at the 'start' point. The same speed is maintained from the 'start' to 'end' points. The distance between 'start' and 'end' is 200m, and the scenario is shown as in Figure 2.

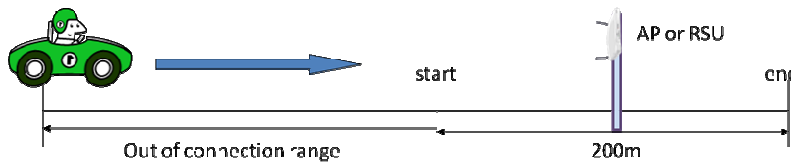

**Figure 2:** Measurement of contact time

### 3.2 Loss comparison in LOS and NLOS environments

In DSRC the vehicles should send safety messages every 100ms and QPSK has been proposed for use as the desired data rate [2, 21]. Based on these suggestions, we set up our experiments, as shown in Table 3.

Multipath propagation is one of the most important characteristics in vehicular communication. 802.11p employs a channel bandwidth of 10 MHz (which is different from 802.11a) and can affect its ability to cope with multipath systems [7]. We perform two sets of experiment, line-of-sight (LOS) and non-line-of-sight (NLOS), to validate whether 802.11p is better than 802.11a in an NLOS environment.

To make a fair comparison, in our experiments we use the same power level, data rate, packet size, and sending rate for both 802.11a and 802.11p. We developed some C programs to transmit WSMP packets between OBU and RSU to collect the packet loss. For the 802.11a experiments, we used a laptop equipped with a 802.11a wireless card as the sender to generate the traffic and an 802.11a AP as the receiver.

**Table 3.** Comparison between 802.11a and 802.11p experiment parameter settings

Parameter	Setting
Modulation	QPSK (1/2)
Transmit power	20 dbm (including antenna gain)
Sampling rate	10 packets/s
Sending time	3 minutes
Packet size	100 bytes
Packet type	WSMP for 802.11p UDP for 802.11a
Tool	Implemented programs
Traffic	CBR, Round-trip
Number of times	10

### 3.2.1 Location and methodology

The experiments were performed on our campus. For the LOS experiment, we collected our data at a campus field which is approximate a  $100 \times 200 \text{ m}^2$  area, as shown in Figure 3. For the NLOS experiment, we set up our testbed around a pond with some rocks and trees at its center, and the transmitter and receiver were placed at opposite sides of the pond, as shown in Figure 4. The devices were placed at a height of 3m on top of a pole. The distance between the transmitter and the receiver was 70m in both experiments.

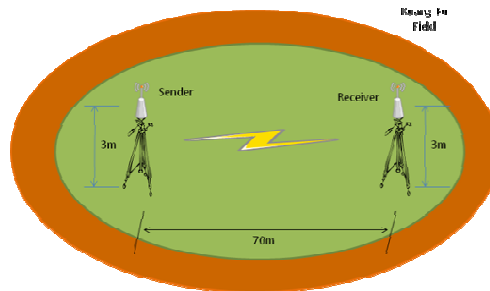

**Figure 3:** For the LOS experiment, we measured on a campus field with no obstacles.

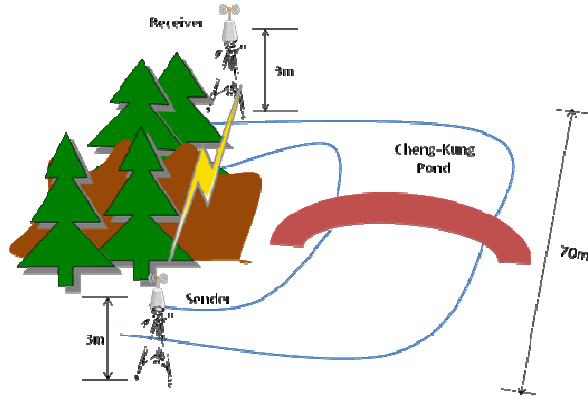

**Figure 4:** For the NLOS experiment, we measured at campus pond with a large rocky area and trees as an obstacle to introduce a multipath system.

### 3.3 Measurements for different modulations of 802.11p

Four different modulations are supported by 802.11p, namely BPSK (1/2), QPSK (1/2), 16QAM (1/2), and 64QAM (3/4). Theoretically, their corresponding data rates are 3Mbps, 6Mbps, 12Mbps, and 27Mbps, respectively. We measured the throughput of 802.11p based on different modulation schemes for various distances. We used 16 dbm (with 5 dbi omnidirectional antenna gain) as the transmission power level due to hardware limitations. The parameter settings are shown in

Table 4.

**Table 4.** Parameter settings

Parameter	Setting
Modulation	BPSK, QPSK, 16QAM, 64QAM
Transmit power	16 dbm
*1 Sending rate	27 Mbps
Sending time	3 minutes
*2 Packet size	1400 bytes
Packet type	WSMP
Tool	Implemented programs
Traffic	CBR, one-way
Number of times	6

\*1 maximum data rate. \*2 maximum packet size of WSM explained on [6]

To avoid the disturbance of passers-by and moving cars, we collected our measurements at midnight. We placed the 802.11p devices at a height of 3m on top of

a pole.

## 4 Results

### 4.1 Contact duration

As there is no authentication/association process in 802.11p, it can set up a connection with the AP much faster than 802.11a can, as shown in Table 5. This means that a 802.11p-equipped car can send much more data to the road-side unit than when 802.11a is used. At the speed of 60Km/hr, the contact duration can be as long as 14 seconds, which is able to support some TCP-based applications like Email or instant messaging (e.g. MSN)

**Table 5.** Contact time

802.11a	Time (sec)	802.11p	Time (sec)
20 Km/h	4.5	20 Km/h	38.5
40 Km/h	0	40 Km/h	19
60 Km/h	0	60 Km/h	14

### 4.2 Loss distributions in LOS and NLOS environments

OFDM symbol provides a cyclic prefix called Guard Interval (GI). If the duration of GI is longer than the duration of all multipath signals following the first signal, the symbols can be restored and thus prevent the symbols suffering from inter-symbol interference (ISI). We repeated our experiments ten times to collect the data loss figures, as shown in Figure 5. In the LOS environment, the losses of 802.11p are close to zero. The highest loss rate among the ten experiments for 802.11p is 2.68%, even in the NLOS environment. Our results show that 802.11p is more robust against the multipath effect as compared to 802.11a. This is because 802.11p has doubled its GI (1.6 us), and, as a result, the multipath effect can be effectively mitigated, and hence it has less loss compared with 802.11a.

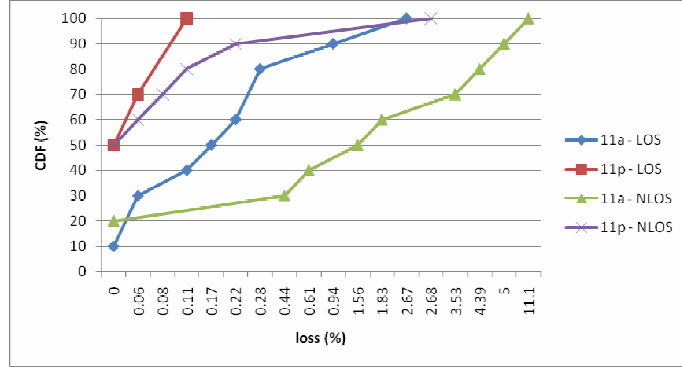

**Figure 5:** The distribution of consecutive packet losses

In addition, by counting the sequence number of transmitted packets, we can investigate the distribution of consecutive packet losses, which indicate how bursty the loss is. As shown in Figure 6, we can find that the packet losses in 802.11a are a bit burstier than that in 802.11p.

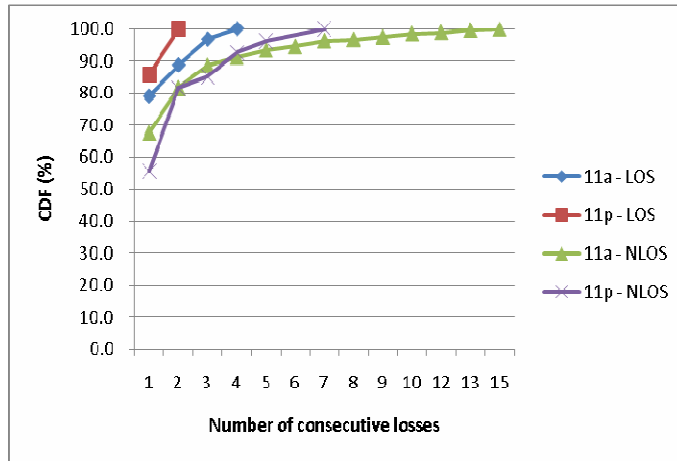

**Figure 6:** The cumulative distribution function for consecutive losses and the number of occurrences.

### 4.3 Measurements for different modulations of 802.11p

Finally, to understand the performance of 802.11p under different bit rates, we measure the throughput of 802.11p over various distances. Theoretically, different modulations have different sensitivity levels.

The sensitivity level is defined as

$$\text{Sensitivity} = R_x \text{ noise floor} + \text{SNR}_{\min} \quad (1)$$

where the  $\text{SNR}_{\min}$  is the minimum SNR needed to obtain the wanted BER. A higher

bit-rate requires a higher SNR; hence, the transmitted signal experiences degradation as the distance between the sender and receiver increases, as a receiver with a high bit-rate is not available to decode bits and this may introduce high bit error rate. As shown in Figure 7 and Figure 8, the achievable throughput of 802.11p is significantly lower than its theoretical counterpart (here we use the log-normal path loss model to model the radio propagation and calculate the theoretical throughput), although their curves are quite similar. The highest achievable data rate using 64QAM is about 18M when the car is very close to the road side unit (< 25m). The longest distance we can achieve with a throughput greater than 2M is 150m, when BPSK is employed. Such a distance and data rate might be sufficient to use the road-side unit as a gateway to the Internet and provide some Internet-based applications for the car. In addition, we observe the variation of throughput becomes larger when we increase the data rate from BPSK to QAM, which is particularly obvious when the car and the road side unit are at a closer distance, as shown in Figure 8.

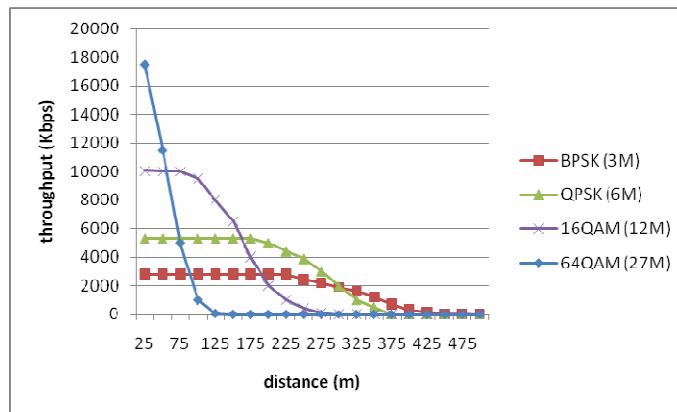

**Figure 7:** Theoretical throughput using different modulation over various distances

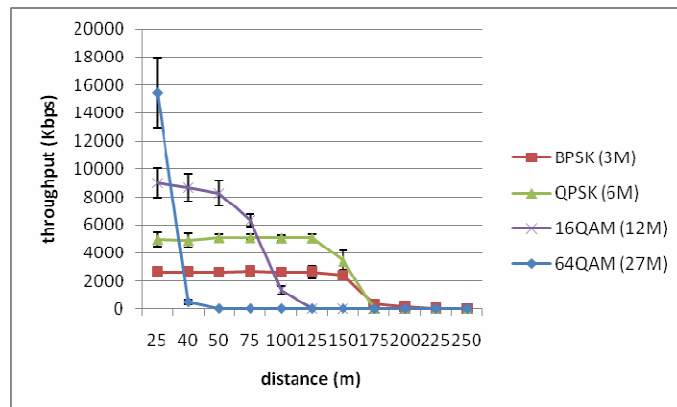

**Figure 8:** The 802.11p throughput using different modulations from our testbed

For the non-safety communication of WAVE, the adaptation of the data rate should be carefully considered to achieve acceptable performance. In this work, we measured the throughput of different modulations over different distances. Our results suggest that, when using DSRC, if the car is far from the road side unit ( $> 150\text{m}$ ), sending the data using a low data rate could achieve better network performance. When the car is close to the road side unit ( $< 25\text{m}$ ), the system might then want to switch to a higher data rate so that it can send more data.

## 5 Conclusions and future work

In this paper, we perform extensive experiments to understand the performance of 802.11p in a real-world scenario, as compared to traditional WiFi, which has been used by most researchers working on V-to-I communication. We find that, as compared to 802.11a, the contact duration between car and the road side until is much longer when 802.11p is used, because the latter does not require any authentication process before setting up a connection. We show that the losses of 802.11p are also significantly lower than those of 802.11a in both LOS and NLOS environments. Finally, we find that the throughput of 802.11p is only around half of its highest theoretical rate. When the highest rate is selected, the throughput could quickly drop to zero when a car moves away from RSU (e.g.  $> 40\text{m}$ ). On the other hand, when the BPSK is used, a stable throughput of at least 2MB can be maintained between the car and the road side until for as far as 150m. In future work, we will look at the effects of other parameters, such as transmission power, user mobility, and interference, on the performance of 802.11p for V-to-I communication.

## Acknowledgment

This work of Dr. Lan described in this paper was supported by NSC under Grant No. NSC99-2220-E-006 -023.

## References

1. Family of Standards for Wireless Access in Vehicular Environments (WAVE). In: IEEE 1609.
2. Standard specification for telecommunications and information exchange between roadside and vehicle systems -5.9 GHz Band Dedicated Short Range Communications (DSRC) Medium Access Control (MAC) and Physical Layer (PHY) Specifications. In: ASTM, (E2213-03) (2003).
3. F. Bai, T. El Batt, G. Holland, H. Krishnan, and V. Sadekar.: Towards characterizing and classifying communication-based automotive applications from a wireless networking perspective. In: First IEEE Workshop on Automotive Networking and Applications

- (AutoNet 2006), in conjunction with Globecom (2006).
4. D. Jiang, V. Taliwal, A. Meier, W. Holfelder, and R. Herrtwich.: Design of 5.9 GHz DSRC-based vehicular safety communication. In: IEEE Wireless Communications, pp. 36–43 (2006).
  5. Draft P802.11p/D3.0: the IEEE 802.11 Working Group of the IEEE 802 Committee (2007).
  6. IEEE 1609.3 Trial-Use Standard for Wireless Accesses in Vehicular Environments (WAVE) - Networking Services, In: IEEE Vehicular Technology Society (2006).
  7. H. Hartenstein, K. Laberteaux.: VANET Vehicular Applications and Inter-Networking Technologies. In: John Wiley & Sons Inc. US. (2010).
  8. M. Müller: WLAN 802.11p measurements for vehicle to vehicle (V2V) DSRC Application Note. In: Rohde & Schwarz (2009).
  9. A. Khan, S. Sadhu, and M. Yeleswarapu: A comparative analysis of DSRC and 802.11 over Vehicular Ad hoc Networks. In: Dept. of Computer Science, University of California (2008).
  10. P. Keeratiwintakorn, E. Thepnorarat, and A. Russameesawang: Ubiquitous Communication for V2V and V2I for Thailand Intelligent Transportation System. In: NTC International Conference, Thailand (2009).
  11. ITRI WAVE/DSRC Communication Unit (IWCU) User's Guide, Version 1.03
  12. M. Lamage, M. H. Manshaei, and T. Turletti.: IEEE 802.11 Rate Adaptation: A Practical Approach. In: ACM MSWiM (2004).
  13. A. Böhm and M. Jonsson: Position-Based Data Traffic Prioritization in Safety-Critical, Real-Time Vehicle-to-Infrastructure Communication. In: Proc. IEEE Vehicular Networking and Applications Workshop (VehiMobil 2009) in conjunction with the IEEE International conference on Communication (ICC), Dresden, Germany (2009).
  14. S. Eichler, S.: Performance Evaluation of the IEEE 802.11p WAVE Communication Standard. In: IEEE 66th Vehicular Technology Conference. VTC-2007, pp.2199--2203 (2007).
  15. I.C. Msadaa., P. Cataldi., F. Filali.: A Comparative Study between 802.11p and Mobile WiMAX-based V2I Communication Networks. In: 2010 Fourth International Conference on Next Generation Mobile Applications, Services and Technologies (NGMAST), pp. 186--191 (2010).
  16. P. Fuxjäger et al.: IEEE 802.11p Transmission Using GNURadio. In Proceedings of the IEEE 6th Karlsruhe Workshop on Software Radios (WSR), pp. 83--86 (2010).
  17. I. N. L. Tan, W. Tang, K. Laberteaux, and A. Bahai: Measurement and analysis of wireless channel impairments in DSRC vehicular communications. In: Elect. Eng. Comput. Sci. Dept., Univ. California, Berkeley, Berkeley, CA, Tech. Rep. UCB/EECS-2008-33 (2008).
  18. Intelligent Transport Systems, <http://www.etsi.org/website/Technologies/IntelligentTransportSystems.aspx>
  19. P. Shankar, T. Nadeem, J. Rosca, and L. Iftode.: CARS: Context Aware Rate Selection for Vehicular Networks. In: ICNP (2008).
  20. K.C. Lee, J.M. Navarro, T.Y. Chong, L. Uichin, M. Gerla.: Trace-based Evaluation of Rate Adaptation Schemes in Vehicular Environments. In: Vehicular Technology Conference (VTC 2010-Spring), pp. 16--19 (2010).
  21. Z. Wang and M. Hassan: How much of DSRC is available for non-safety use. In: ACM VANET 2008, pp.23--29 (2008).
  22. J. Miller, E. Horowitz.: FreeSim – A Free Real-Time Freeway Traffic Simulator. In: IEEE 10th Intelligent Transportation Systems Conference (2007).
  23. K.C. Lan, C.M. Huang, C.Z. Tsai, On the locality of vehicle movement for vehicle-infrastructure communication, Eight International Conference on ITS Telecommunications, pp. 116-120, Oct. 2008
  24. [http://www.its.dot.gov/cicas/cicas\\_current\\_act.htm](http://www.its.dot.gov/cicas/cicas_current_act.htm)
  25. <http://www.cohdawireless.com/>

