

Improved Joint Pilot Allocation and Channel Estimation Algorithm for OFDM System

Latif Ullah Khan, Sahibzada Ali Mahmud, Gul Muhammad Khan, Muhammad Haseeb Zafar, Zeeshan Shafiq

Center for Intelligent Systems & Network Research (CISNR)
University of Engineering & Technology/Peshawar, Pakistan
latifullahkhan@nwfpuet.edu.pk

ABSTRACT

A novel pilot insertion and channel estimation algorithm for orthogonal frequency division multiplexing (OFDM) systems over slow fading channels is presented. The pilots overhead in the proposed insertion technique is reduced to 12.5% as compared to conventional block type channel estimation. The proposed channel estimation algorithm is aimed at reducing the channel noise, which is inherent in the least square (LS) estimation. The proposed channel estimation algorithm uses LS for channel impulse response estimation at pilot subcarriers. The channel frequency response at all of the subcarriers for the entire block is estimated by using the inverse fast Fourier transform (IFFT), zero padding, and the fast Fourier transform (FFT). The performance (in terms of the bit error rate) of the proposed channel estimation algorithm and the pilot arrangement is compared with the LS estimation for block-type pilot arrangement. Simulation results show that the proposed channel estimation algorithm outperforms the block-type pilot arrangement with LS estimation.

Keywords

OFDM, LS Estimator, Slow Fading channel, Channel Estimation.

1. INTRODUCTION

ROBUSTNESS to channel impairments and spectral efficiency has made orthogonal frequency division multiplexing (OFDM) the most preferable candidate for communication systems. Communication standards, such as Wi-Fi, Wi-Max, digital video broadcasting (DVB), and digital audio broadcasting (DAB) have adopted OFDM [1], [2]. Spectral efficiency of the OFDM is due to the overlapping nature of the orthogonal subcarriers. Guard interval is used in the OFDM to avoid inter-symbol interference (ISI). However, in single carrier communication systems, complex equalization techniques are used for ISI cancellation [3]. Frequency selective fading channel significantly degrades the performance of OFDM system. Moreover, channel state information (CSI) is necessary to improve the performance of OFDM system in the presence of multipath fading channel. Therefore, channel estimation plays a pivotal role in efficiently operating a communication system.

Channel estimation can be divided into three types based on the density of the pilot symbols: (a) pilot assisted, (b) blind, and (c) semi-blind channel estimation [4]. In *pilot assisted* channel estimation techniques, known pilot symbols are transmitted along with the OFDM data symbols. The receiver uses the received and transmitted pilot symbols to estimate the channel frequency response. In the *blind* channel estimation, the channel impulse response is estimated through the use of received signal statistics.

In the *semi-blind* channel estimation, pilot symbols are inserted into the OFDM symbol to improve the performance of the blind estimation. Block-type and comb-type channel estimation are the two categories of one-dimensional pilot aided channel estimation techniques, which are based on the arrangement of pilot tones [5]. Comb-type channel estimation is used to estimate the channel frequency response for the fast fading channels. Block-type channel estimation is used for estimation of the channel frequency response for slow fading channels.

In [6], Sabir *al* proposed a model for inter-carrier interference (ICI) cancellation and error correction in OFDM system. The performance of the proposed model is evaluated for the slow fading Rayleigh channel. LS estimator with Block-Type pilot arrangement is used for ICI mitigation. The proposed model exhibits acceptable performance; however, the pilot overhead associated with block-type channel estimation is 14.5%. The LS estimator has degraded performance due to its susceptibility to noise which makes the system unattractive for practical implementation. The error correction performance in the proposed system model can be improved by increasing the number of decoder iterations; however, increasing the number of decoder iterations subsequently increases the computational complexity. Therefore a trade-off must be made between the performance and complexity of the decoder.

In [7], the complexity associated with Linear Minimum mean square error (LMMSE) estimator is reduced by partitioning the channel auto correlation matrix into sub matrices by overlap and non-overlap techniques. The performance of the proposed techniques is degraded as compared to the LMMSE and better than LS estimator. The proposed LMMSE estimation techniques have reduced complexity associated with matrix multiplication; however, the disadvantage of the proposed technique is the requirement of the power delay profile for their operation. In [8], the block-type and comb-type channel estimation techniques are used in the OFDM. The channel at pilot subcarriers is estimated by using LS estimator for comb-type pilot insertion scheme. The performance of the LS estimator for different interpolation techniques in case of comb-type pilot arrangement is also studied. Low pass interpolation outperforms other one-dimensional interpolation techniques. LS estimator is susceptible to noise and therefore, it has degraded performance as compared to MMSE estimator.

In this paper, a novel pilot arrangement scheme and a channel estimation algorithm using the LS estimator is proposed. LS estimator is considered because of its non-requirement of the power delay profile [9],[10]. The proposed pilot insertion technique has low over-head as compared to pilot arrangement in the block-type channel estimation. The pilot overhead is reduced to 1/8 in the proposed pilot arrangement scheme as compared to

block-type channel estimation. The proposed channel estimation algorithm reduces noise present in the LS estimation, which consequently significantly improves the performance of the OFDM system. The noise is cancelled out in the LS estimator by using the concept of the concentrated channel energy in time domain and distributed channel energy in frequency domain. The performance of the comparison of the proposed channel estimation algorithm and LS estimator with block-type channel estimation shows the performance improvement of the proposed technique.

The remainder of the paper is organized as follows: Section II describes the OFDM system model. Section III explains the channel estimation algorithms. Simulation results are discussed in Section IV and we conclude the paper in Section V.

2. OFDM SYSTEM MODELING

In OFDM systems (as can be seen in Fig. 1), the input bits are mapped to produce the frequency domain symbols. The serial sequence of symbols is parallelized and pilots are inserted into the sequencing. The pilots and data symbols can be mathematically quantified by:

$$X_d = X(I_d) \quad (1)$$

$$X_p = X(I_p) \quad (2)$$

Where I_d and I_p are the vectors containing data indices and pilots sub carriers, respectively. The parallelized sequence of symbols, after pilot insertion, is fed to inverse fast Fourier transform (IFFT) block to convert the sequence of symbols from the frequency domain into the time domain. The output of the IFFT block is given by:

$$\begin{aligned} x(n) &= IFFT(X), \\ &= \sum_{m=0}^{N-1} X(j) e^{j \frac{2\pi m n}{N}} \quad n = 0, 1, \dots, N-1 \end{aligned} \quad (3)$$

A cyclic prefix of length L_{CP} is then added to the OFDM symbol to cancel out ISI. The length of L_{CP} should be used greater than or equal to the channel order to effectively mitigate ISI. Finally, the signal is transmitted through the multipath fading channel in the presence of additive white Gaussian noise (AWGN).

$$y = x \otimes h + \xi, \quad (4)$$

Where h is the channel impulse response, ξ is AWGN vector, and \otimes represents the convolution operation. The signal after the removal of the cyclic prefix is passed through the fast Fourier transform (FFT) block to obtain the frequency domain signal.

$$\begin{aligned} Y(k) &= FFT(y(n)), \\ &= \sum_{n=0}^{N-1} y(n) e^{-j \frac{2\pi k n}{N}} \end{aligned} \quad (5)$$

Thereafter, the channel estimation and equalization of the signal are de-mapped to yield the output bits. The performance of the system is evaluated in terms of bit error rate (BER).

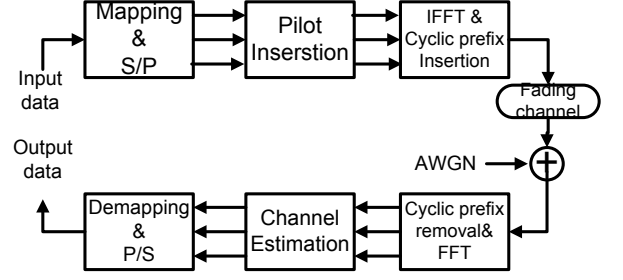

Figure 1. Baseband OFDM System

3. CHANNEL ESTIMATION ALGORITHM FOR SLOW FADING CHANNELS

The block-type pilot arrangement is used for the slow fading channels [5]. In the block-type pilot arrangement, the first OFDM symbol of the block consisting completely of the pilot tones is transmitted over the multipath fading channel as shown in Fig. 2. The channel frequency response estimated by using the first symbol in a block is then used for the equalization of the remaining symbols in the same block. The aforementioned is a viable solution because of the assumption of the constant channel impulse response over the entire block for slow fading channels [11]. Block-type channel estimation is normally used for slow fading channel with same pilot overhead as comb-type channel estimation for the fast fading channel. The performance of the OFDM system for slow fading channels is better for block-type pilot arrangement as compared to comb-type channel estimation because of the avoidance of interpolation error that is inherent in comb-type channel estimation. In block-type channel estimation, the pilot symbols are inserted into all subcarriers in the first OFDM symbol of the block. The advantage of this type of pilot arrangement is getting rid of the interpolation error and effective tracking ability of the slow fading channel.

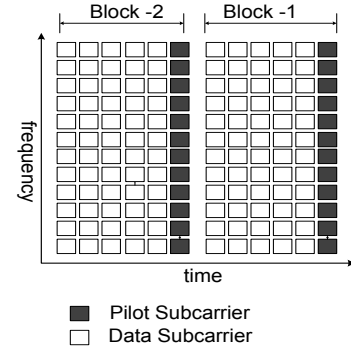

Figure 2. Arrangement of Pilots in Block-Type Channel Estimation

3.1 LS Estimator

The minimization of the square of the difference between the estimated and the detected signal is the basis of LS estimator operation as depicted in Fig. 3. The LS estimate of the channel is given by [12]:

$$H_{LS} = \frac{Y(k)}{X(k)}, \quad K = 0, 1, 2, 3, \dots, P-1 \quad (6)$$

where $Y(k)$ and $X(k)$ represents the received and transmitted pilot symbols at k^{th} subcarrier, respectively. The channel frequency response computed from the first symbol is then used for the equalization of the subsequent symbols in the block. It is clear from Fig. 3 that the signal estimated by the LS estimator does not consider the effect of channel noise in the estimation process and thus, susceptible to noise which results in the performance degradation of the OFDM system. The performance of the LS estimator can be improved by minimizing the noise that is inherent in the LS estimation.

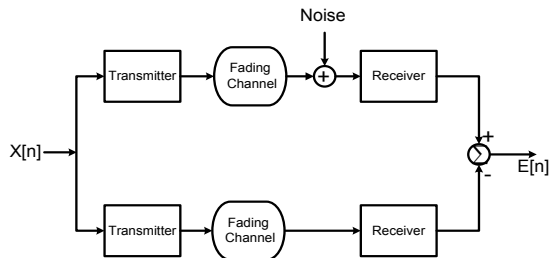

Figure 3. Conceptual View of LS estimator

3.2 Proposed Channel Estimation Algorithm and Pilot Insertion Scheme

In the time domain, the energy of the channel impulse response is concentrated [13]. Because of the existence of the fading impulse at integer multiples of the system sampling rate (in sampled spaced channels), there is no channel energy leakage between the channel taps. The energy of the channel impulse response is concentrated in the first $L \leq L_T$, where L is the channel order and L_T is the cyclic prefix length, taps in time domain. The channel impulse response estimated by the LS estimator is given by:

$$h_{LS}(n) = IFFT(H_{LS}(K)), \quad n = 0, 1, 2, \dots, N-1$$

$$= \hat{h}_{LS}(n) + \hat{w}(n) \quad (7)$$

where $\hat{w}(n) = IFFT\left(\frac{W(K)}{X(K)}\right)$. All of the channel impulse response energy is contained within the first L taps less than or equal to the guard interval. Therefore, the channel impulse response can be written as:

$$h(n) = \begin{cases} IFFT(H_{LS}(K)), & 0 \leq n \leq L-1 \\ 0 & L \leq n \leq N-1 \end{cases} \quad (8)$$

Equation (7) can be modified as:

$$h_{LS}(n) = \begin{cases} \hat{h}_{LS}(n) + \hat{w}(n) & 0 \leq n \leq L-1 \\ \hat{w}(n) & L \leq n \leq N-1 \end{cases} \quad (9)$$

From Equation (9), we can gather that beyond the first L taps, the estimated channel response consists of noise. Therefore, the performance of the LS estimator can be improved by only considering the first L taps and ignoring the other taps in the estimation of the channel frequency response. The channel energy distribution in time and frequency domain is depicted in Fig. 4, which shows that only L taps are significant energy taps. This suggests the placement of uniformly distributed L pilots per OFDM symbol. The proposed pilot insertion scheme for slow fading channel is shown in Fig. 4. The overhead associated with the proposed pilot insertion scheme is $\frac{1}{4}$ for cyclic prefix of length $\frac{1}{4}$ as compared to the conventional block-type pilot insertion technique. The effect of this type of arrangement is the reduced pilot overhead and improved performance for the proposed

channel estimation algorithm, which is depicted in Fig. 5. The proposed channel estimation consists of the following steps:

- The LS estimate is computed by (6) for P pilots.
- The output of the LS estimated is fed to P -point IFFT block to convert the frequency domain sequence into time domain sequence. The resultant time domain sequence has channel energy concentrated into the first L taps and noise beyond the first L taps for sampled spaced channel.
- Pad $N - L$ zeros at the end of the time domain channel vector containing the first L values computed channel impulse response in step 2 to cancel out noise in the time domain channel impulse response.
- Finally, take N -point FFT of the zero padded time domain sequence to compute the channel frequency response at all subcarriers.

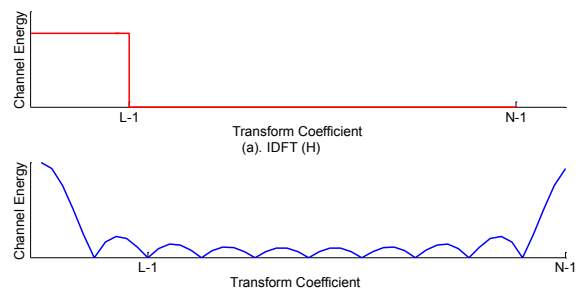

Figure 4. Channel Energy Distribution in (a) Time domain (b) Frequency Domain

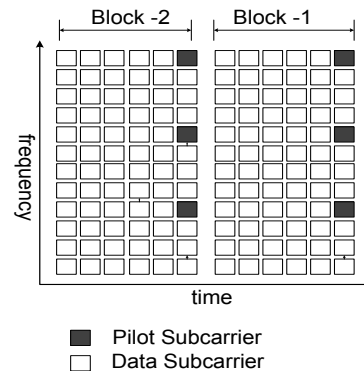

Figure 5. Proposed Pilot Arrangement

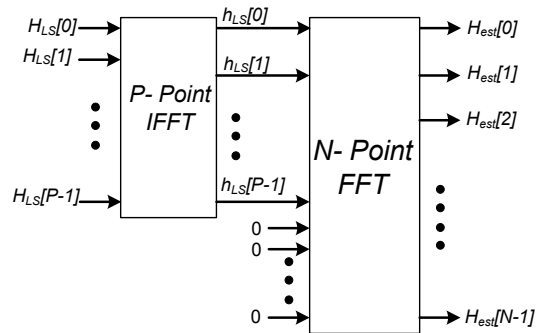

Figure 6. Proposed Channel Estimation Algorithm

4. SIMULATION RESULTS

This section presents the MATLAB® simulation results for performance evaluation of the proposed channel estimation and LS estimator with block-type pilot arrangement over frequency selective slow fading channel. Simulation parameters are given in table I. The channel consists of L independent taps of Gaussian distribution with zero mean and variance σ_i^2 , $i = 0, 1, 2, \dots, L_T - 1$. Exponential power delay profile is adopted in this paper. The variance of each tap is given by:

$$\sigma_i^2 = e^{-\frac{l}{45}} \quad l = 0, 1, 2, \dots, L - 1 \quad (10)$$

Table 1. Simulation Parameters

Parameters	Specifications
Number of subcarriers, N	512
FFT size	512
Cyclic Prefix Length	¼ i.e. 64
Channel Type	slow fading Rayleigh
Digital Modulation Schemes	BPSK, QPSK, 16-QAM, 32-QAM, 64-QAM

Simulated frame structure is shown in Fig. 6. Each frame consists of 7 OFDM symbols and the first symbol of each block has both data and pilot tones at specified subcarriers in case of the proposed pilot insertion and channel algorithm respectively. The pilots are inserted in the first symbol of the block at specified subcarriers resulting in pilot overhead of 1.78% for entire block of 7 symbols. The computed overhead for the proposed pilot insertion scheme is very low as compared to block type pilot arrangement which results in pilot overhead of 14.29% for the simulated frame of Fig. 7. In block-type channel estimation, the first symbol contains pilots at all subcarriers for the frame structure of Fig. 7. The channel impulse response is considered constant for a block period of time (slow fading channel) and assumption of perfect synchronization is made. The legends ‘LS’ and ‘Proposed’ correspond to LS estimator with block-type pilot arrangement and Proposed channel estimation algorithm with proposed pilot insertion scheme, respectively.

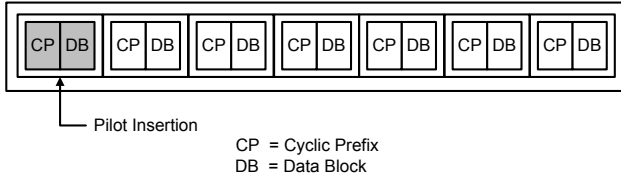

Figure 7. Simulated Frame Structure [14]

Figs. 8 and 9 illustrate the BER performance comparison of the proposed channel estimation algorithm with proposed pilot insertion scheme and LS estimator with block type pilot arrangement. It is clear from the Figs. 8 and 9 that the proposed channel estimation algorithm outperforms LS estimator with block type pilot arrangement. Table II shows the BER values at SNR=40 dB for different modulation schemes for the proposed algorithm and LS estimator for block-type pilot arrangement. Table II also clearly reveals the performance improvement of

proposed channel estimation algorithm over LS estimator for block-type arrangement. The reason for this improvement in BER performance is the cancellation of inherent noise in LS estimator in the proposed channel estimation algorithm. It is also clear from Figs. 8 and 9 that the BER performance for higher modulation schemes degrades as compared to lower modulation schemes. This degradation is because of the close positioning of the constellation points for higher modulation schemes.

Table 2. BER Values at SNR=40 dB

Modulation Scheme	Proposed Algorithm	LS estimator with Block-type Pilot Arrangement
BPSK	2.98×10^{-5}	5.53×10^{-5}
QPSK	7.25×10^{-5}	14.47×10^{-4}
16-QAM	2.30×10^{-4}	6.04×10^{-4}
32-QAM	5.18×10^{-4}	14.6×10^{-4}
64-QAM	9.50×10^{-4}	29.23×10^{-4}

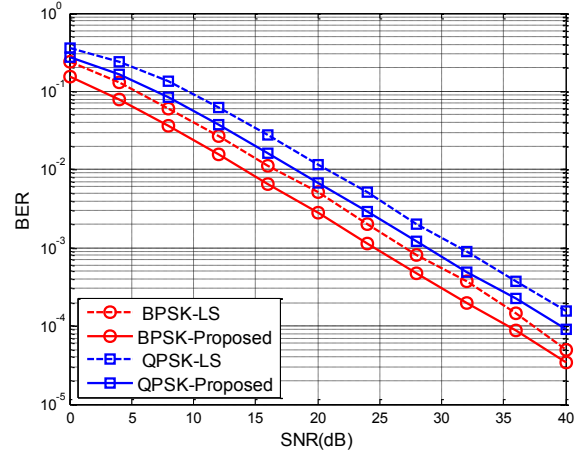

Figure 8. Performance Comparison of Estimators in OFDM for BPSK and QPSK modulation schemes

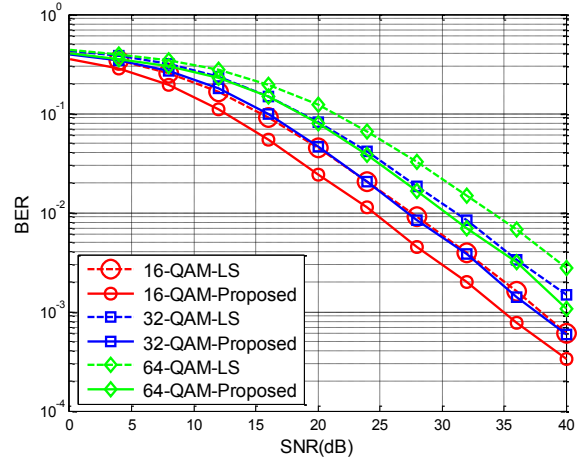

Figure 9. Performance Comparison of Estimators in OFDM for 16-QAM, 32-QAM and 64-QAM modulation schemes

5. CONCLUSIONS

A novel pilot arrangement scheme with low overhead and improved channel estimation algorithm using the least square (LS) estimator was proposed for OFDM systems over slow fading channels. The performance (in terms of the bit error rate) of the proposed channel estimation algorithm and the pilot arrangement was compared with the LS estimation for block-type pilot arrangement. Simulation results revealed a significant performance improvement of the proposed pilot arrangement and channel estimation algorithm over the LS estimator with block-type pilot arrangement. The pilot overhead is reduced to 12.5% in the proposed arrangement as compared to block-type scheme.

As future work, the channel frequency response can be estimated through minimum mean square error (MMSE) estimator for the proposed pilot arrangement scheme. A performance comparison between the LS estimator and MMSE estimator will be made in order to check the performance improvement of MMSE estimator over LS estimator, because the MMSE estimator takes into account channel statistics for performance improvement.

6. REFERENCES

- [1] A. B. Narasimhamurthy, M. K. Banavar, and C. Tepedeleniogly, 2010. *OFDM Systems for Wireless Communications*, Morgan and Claypool Publishers, NJ, USA.
- [2] J. Armstrong, 2012. Tutorial on Optical OFDM. in *14th International Conference on Transparent Optical Networks (ICTON)*, (Coventry, UK, 2012).
- [3] Z. Yang, W. Bai, and Z. Liu, 2006. A Decision-Aided Residual ISI Cancellation Algorithm for OFDM Systems. in *8th IEEE International Conference on Signal Processing*. (Beijing, China, 2006), 16-20.
- [4] M. Almeida, 2011. *Vehicular Technologies: Increasing Connectivity*, Intech Publisher.
- [5] L.U. Khan, M.I. Babar, Z. Sabir, 2013. Robust modified MMSE estimator for comb-type channel estimation in OFDM systems. In *the proceedings of 15th International Conference on Advanced Communication Technology (ICACT)*, (PyeongChang, South Korea, 27-30 Jan. 2013), 924,928
- [6] Z. Sabir, M. I. Babar, S. W. Shah, 2012. Performance enhancement of wireless mobile adhoc networks through improved error correction and ICI cancellation. *EURASIP Journal on Advances in Signal Processing*. 2012
- [7] M. Noh, Y. Lee, and Park, 2006. Low Complexity LMMSE Channel Estimation for OFDM. *IEE Proceedings on Communications*. 153(5) (2006), 645-650.
- [8] S. Coleri, M. Ergen, A. Puri, and A. Bahai, 2002. Channel Estimation Techniques Based on Pilot Arrangement in OFDM Systems. *IEEE Transactions on Broadcasting*. 48(3) (2002), 223-229
- [9] Y. Qiao, S. Yu, P. Su, and L. Zhang, 2005. Research on an Iterative Algorithm of LSChannel Estimation in MIMO OFDM Systems. *IEEE Transactions on Broadcasting*. 51(1)(2005), 149-153
- [10] W. Su, and Z. Pan, 2007. Iterative LS Channel Estimation for OFDM Systems based on Transform-Domain Processing. in *Proc. WICOM. conf.* (Shanghai, China, September 2007), 416-419.
- [11] O. Edfors, M. Sandell, I.-J. van de Beek, , S. K. Wilson, P. O. Borjesson, 1998. OFDM Channel Estimation by Singular Value Decomposition. *IEEE Transactions on Communications*. 46(7), 931-939.
- [12] Z. Sabir, M. A. Wahla , M. I. Babar, 2011. OFDM, Turbo Codes and Improved Channel Estimation—A Magical Combination, VDM Verilog Publishers,Germany.
- [13] M.-H. Hsieh, and C.-H. Wei, 1998. Channel Estimation for OFDM Systems based on Comb-type Pilot Arrangement in Frequency Selective Fading Channels. *IEEE Transactions on Consumer Electronics*,44(1)(1998),217-225
- [14] J. Ma, H. Yu, and S. Liu, 2009. The MMSE Channel Estimation Based on DFT for OFDM System. in *5th International Conference onWireless Communications, Networking and Mobile Computing (WiCom)*,(Beijing, China, 2009),1-4.
- [15] R. Prasad, 2004. *OFDM for Wireless Communication Systems*, Artech House Inc., Boston, USA.