

Hierarchical Codebook Design for Massive MIMO

Xin Su¹, Shichao Yu^{1,2}, Jie Zeng^{1,*}, Yujun Kuang²

¹Tsinghua National Laboratory for Information Science and Technology, Tsinghua University, Beijing, China

²University of Electronic Science and Technology of China (UESTC), Chengdu, China

Abstract

The Research of Massive MIMO is an emerging area, since the more antennas the transmitters or receivers equipped with, the higher spectral efficiency and link reliability the system can provide. Due to the limited feedback channel, precoding and codebook design are important to exploit the performance of massive MIMO. To improve the precoding performance, we propose a novel hierarchical codebook with the Fourier-based perturbation matrices as the subcodebook and the Kerdock codebook as the main codebook, which could reduce storage and search complexity due to the finite alphabet. Moreover, to further reduce the search complexity and feedback overhead without noticeable performance degradation, we use an adaptive selection algorithm to decide whether to use the subcodebook. Simulation results show that the proposed codebook has remarkable performance gain compared to the conventional Kerdock codebook, without significant increase in feedback overhead and search complexity.

Keywords: Massive MIMO, Kerdock codebook, Fourier-based perturbation, adaptive selection.

Received on 06 March 2014, accepted 28 May 2014, published on 17 February 2015

Copyright © 2015 Xin Su *et al.*, licensed to ICST. This is an open access article distributed under the terms of the Creative Commons Attribution licence (<http://creativecommons.org/licenses/by/3.0/>), which permits unlimited use, distribution and reproduction in any medium so long as the original work is properly cited.

doi: 10.4108/sis.2.4.e5

1. Introduction

Generally, for the MIMO system, the more antennas the transmitters/receivers equipped with, the higher degree of freedom that the propagation channels can provide, and the higher spectral efficiency, link reliability the system can provide [1]. Therefore, to meet the rapidly increasing demand of high-rate driven by the proliferation of mobile PCs, Smartphones, tablets, etc., and to exploit the precious wireless frequency resources, the massive MIMO system with numerous antennas in the base station (BS) has become an emerging research field. Moreover, in the research of fifth-generation mobile communication system (5G), massive MIMO has become an important research direction.

However, for practical application, the number of antennas should be restricted. Given a fixed number of antennas, we need to explore the massive MIMO system potentials through precoding techniques, which can mitigate the inter-user interference and improve the received SNR. In a closed-loop MIMO frequency division duplexing (FDD) system, the same codebook with a finite set of precoding matrices known to both the transmitter and the receiver should be pre-designed. A larger size codebook can increase the performance of precoding (i.e. Beamforming) at the cost of increasing the uplink feedback overhead, the storage

requirement and search complexity. Therefore, it is important to explore better approaches for codebook design to balance the accuracy of precoding and the feedback overhead, and thus optimizing the overall performance.

There is a rich body of literature on the codebook design for traditional MIMO systems. But for the massive MIMO system, they have some disadvantages. Paper [2] has proposed a codebook based on vector quantization, which takes the channel distribution into account, resulting in a need of re-design when the channel distribution changes. The codebook based on Grassmannian packing in [3], [4] is nearly the optimal codebook for uncorrelated channels, but its construction requires numerical iterations, high storage requirement and search computational requirement, and thus restricts its application in massive MIMO. The Discrete Fourier Transform (DFT) codebook with simple systematic construction and appropriate storage requirement has been proposed in [5], but its performance is too low to meet the precoding requirement of massive MIMO, especially under the uncorrelated channels. Compared to these codebooks, the Kerdock codebook [6] can be extended and applied to massive MIMO system easily since its considerable precoding performance with reduced storage and selection computational requirements, besides, it has the characteristics of finite quaternary alphabet and systematic construction.

*Corresponding author. Email: zengjie@tsinghua.edu.cn

In a massive MIMO system, the feedback overhead, storage requirement and codeword searching computational complexity would be significantly increased when the antenna array grows large. To compromise the system performance and feedback overhead, we propose a new hierarchical codebook combining the characteristics of the Kerdock main codebook with the Fourier based perturbation subcodebook. Moreover, to subtract the unnecessary feedback overhead for subcodebook, which has no influence on the precoding performance in some cases, we propose an adaptive selection algorithm to decide when to adopt the hierarchical codebook or the Kerdock codebook only according to the SNR differences among data streams.

The rest of the paper is organized as follows. Section 2 introduces the system model. Section 3 presents the detail design of a hierarchical codebook as well as an adaptive selection algorithm. Simulation results are shown in Section 4. Finally, Section 5 gives the conclusions.

2. System Model

In this paper, we focus on the downlink of a massive MIMO system with N_t transmit antennas at the BS and N_r receive antennas at the user equipment(UE). We adopt the closed-loop MIMO transmission architecture with precoding and feedback mechanism.

Generally, the data processing at the transmitter has a number of steps. Firstly, the data stream which is inputted into the system would be demultiplexed into L substreams, then we get the substream vector $\mathbf{s} = \{s_1, s_2, \dots, s_{N_t}\}$. L is limited by $1 \leq L \leq \min(N_t, N_r)$. The condition when $L = 1$ is the case of transmission beamforming, while $L > 1$, we call it multiplexing. Next the data is preprocessed by a precoding matrix \mathbf{W} , which is chosen from the codebook stored in the transmitter according to the reported Precoding Matrix Indicator (PMI), the transmitted signal \mathbf{x} shows:

$$\mathbf{x} = \mathbf{W}\mathbf{s} \quad (1)$$

After preprocessed data passing the channel and being added the noise, the signal received by the UE can be expressed as:

$$\mathbf{y} = \mathbf{H}\mathbf{W}\mathbf{s} + \mathbf{z} \quad (2)$$

where $\mathbf{H} \in (N_r \times N_t)$ denotes the fading channel matrix with its entry H_{ij} denoting the channel response from the j -th transmit antenna to the i -th receive antenna, and \mathbf{z} denotes the white complex Gaussian noise (AWGN) vector with covariance matrix $N_0\mathbf{I}_{N_r}$.

Then turn to the hierarchical codebook in limited feedback precoding system. Fig. 1 illustrates the precoding model of hierarchical codebook. It is constructed by two parts, including the main codebook

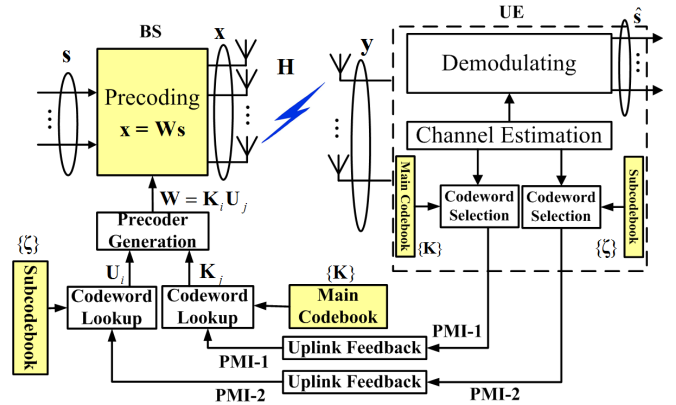

Figure 1. The Limited Feedback Precoding Model

$\mathbf{K} = \{\mathbf{K}_1, \mathbf{K}_2, \dots, \mathbf{K}_N\}$ as the first part and the subcodebook $\zeta = \{\mathbf{U}_1, \mathbf{U}_2, \dots, \mathbf{U}_G\}$ as the second part. Assuming that the feedback overhead is limited to B bits, the size of these two parts should satisfy $N \times G = 2^B$. Through receiving the reference signals from the BS and estimating the channel to acquire the Channel State Information (CSI), the UE can select an optimal codeword from \mathbf{K} and ζ respectively according to the CSI and report the corresponding indexes of precoding matrix named as PMI to the BS via the limited feedback channel [7]. Combining the two matrix \mathbf{K}_i and \mathbf{U}_j from the main codebook and the subcodebook respectively, the precoding matrix can be constructed as $\mathbf{W} = \mathbf{K}_i \mathbf{U}_j$. Then the (2) can be rewritten as:

$$\mathbf{y} = \mathbf{H}\mathbf{K}_i \mathbf{U}_j \mathbf{s} + \mathbf{z} \quad (3)$$

At the receiver, the UE obtains the estimated channel matrix through channel estimation and demodulates the received signal by employing various methods, such as Zero-Forcing (ZF) or Minimum Mean Square Error (MMSE), etc.

3. Design of the Novel Hierarchical Codebook

For limited feedback precoding, codebook design is crucial. With the characteristics of quaternary alphabet and systematic construction, Kerdock codebook has relatively low storage requirement and selection computational requirement, which are critical factors in massive MIMO system. However, it is not sufficient since the number of precoding matrices based on the Kerdock is limited. Paper [11] has proved that adding the unitary perturbation to codebook could improve the performance of the codebook with the linear ZF or MMSE receiver. In order to enhance the performance of the massive system, we propose a hierarchical codebook which adopts Kerdock as the first part of the codebook,

Table 1. Codebooks for $L = 1 \sim 4$

L	1	2	3	4
Codeword \mathbf{K}_i		$\mathbf{Y}_{k_i}^{[L_i]}$		
Index i		$32k_2 + k_1$		
k_1		0-31		
k_2	0-31	0-15	0-7	0-7
Size(bits)	10	9	8	8

Note: $L_i = Lk_2, Lk_2 + 1, \dots, Lk_2 + L - 1$

and Fourier-based perturbation matrices as the second part. Moreover, based on the proposed hierarchical codebook, we proposed an adaptive selection algorithm to decide when to use the subcodebook.

3.1. Main codebook design

The basic idea of the Kerdock codebook design is using the feature of Mutually Unbiased Bases (MUB) to construct the precoding matrix, and with the main feature that all the elements of the matrix in the codebook are composed of ± 1 and $\pm j$.

An MUB is the set of bases satisfying the mutually unbiased property. Supposing $\mathbf{S} = \{\mathbf{s}_1, \mathbf{s}_2, \dots, \mathbf{s}_M\}$ and $\mathbf{Q} = \{\mathbf{q}_1, \mathbf{q}_2, \dots, \mathbf{q}_M\}$ are two $M \times M$ orthonormal bases. If the column vectors drawn from \mathbf{S} and \mathbf{Q} satisfy $|\langle \mathbf{s}_i, \mathbf{q}_j \rangle| = 1/\sqrt{M}$, we can say that they have the mutually unbiased property [8].

The Kerdock codebook has several construction methods such as Sylvester-Hadamard construction and power construction [6]. In this paper, we adopt the Sylvester-Hadamard construction. The construction method is presented as follows:

Firstly, we generate a number of diagonal matrices \mathbf{D}_n with the size of $N_t \times N_t$, for $n = 0, 1, 2 \dots, N_t - 1$, $N_t = 2^B$, i.e., N_t should be the power of 2. The details about their generation can be referred to [9].

Then we construct the corresponding orthogonal matrix:

$$\mathbf{Y}_n = \frac{1}{\sqrt{N_t}} \mathbf{D}_n \hat{\mathbf{H}}_{N_t} \quad (4)$$

where $\hat{\mathbf{H}}_{N_t}$ is the $N_t \times N_t$ Sylvester-Hadamard matrix:

$$\hat{\mathbf{H}}_{N_t} = \hat{\mathbf{H}}_2 \otimes \hat{\mathbf{H}}_2 \dots \quad (5)$$

$$\text{where } \hat{\mathbf{H}}_2 = \begin{pmatrix} 1 & 1 \\ 1 & -1 \end{pmatrix}$$

Finally, we need to construct the codebook by selecting unique column combinations from each \mathbf{Y}_n according to the number of substreams, i.e. L . Taking $N_t = 32$ as an example, the codebooks for $L = 1 \sim 4$ are shown in Table 1.

Besides, having the estimated channel matrix, the codeword selection is an important issue. In this paper, for the main codebook, we choose the Minimum

Singular Value Selection Criterion (MSV-SC) to select the optimal codeword from \mathbf{K} .

For the beamforming, the beamformer that minimizes the probability of symbol error for maximum ratio combining receiver is expressed as:

$$\hat{\mathbf{f}}[i] = \arg \max_{\mathbf{f} \in \mathbf{K}} \|\mathbf{H}[i]\mathbf{f}\|_2^2 \quad (6)$$

where \mathbf{f} denotes a $N_t \times 1$ matrix.

For spatial multiplexing with a ZF receiver, the minimum singular value selection criterion is expressed as:

$$\hat{\mathbf{F}}[i] = \arg \max_{\mathbf{F} \in \mathbf{K}} \lambda_{\min}\{\mathbf{H}[i]\mathbf{F}\} \quad (7)$$

where λ_{\min} denotes the minimum singular value of the argument. This selection criterion approximately maximizes the minimum substream Signal-to-Noise Ratio (SNR).

3.2. Fourier-based perturbation subcodebook design

Several methods for constructing hierarchical codebooks have been proposed in [10]. Rotation-based perturbation is simple but it demands a large number of matrices to gain high performance. In this paper, we employ a novel construction method with Fourier based perturbation matrices since it can track the short-term change of the channel and deal with the SNR imbalance among the substreams.

Because of the high throughput of massive MIMO system, our main consideration of subcodebook design is the bit error ratio (BER) improvement. The unitary perturbation can enhance the performance of the codebook with linear receivers like ZF and MMSE. Using the linear ZF receiver, the SNR of the k -th data stream can be expressed as:

$$\text{SNR}_k(\mathbf{H}, \mathbf{K}_p) = \frac{1}{N_0 [(\mathbf{K}_p^H \mathbf{H}^H \mathbf{H} \mathbf{K}_p)^{-1}]_{kk}} \quad (8)$$

Then we add the perturbation matrix \mathbf{U}_p to the precoding matrix: $\mathbf{W}_p = \mathbf{K}_p \mathbf{U}_p$ (\mathbf{K}_p is the main codebook). We know that the BER performance of a precoding system is dominated by the performance of the substream with the lowest SNR. So the best condition is that every substream has an equivalent SNR. Using ZF receiver, the lowest SNR can be expressed as:

$$\begin{aligned} \text{SNR}_{\min}^{\text{ZF}}(\mathbf{H}, \mathbf{W}_p) &= \min_{1 \leq k \leq L} \text{SNR}_k^{\text{ZF}}(\mathbf{H}, \mathbf{W}_p) \\ &= \frac{1}{\max_{1 \leq k \leq L} (N_0 [\mathbf{U}_p^H (\mathbf{K}_p^H \mathbf{H}^H \mathbf{H} \mathbf{K}_p)^{-1} \mathbf{U}_p]_{kk})} \end{aligned} \quad (9)$$

We can see that the SNRs of the substreams are determined by the diagonal elements of the matrix $(\mathbf{U}_p^H \mathbf{F}_p^H \mathbf{H}^H \mathbf{H} \mathbf{F}_p \mathbf{U}_p)^{-1}$. For pursuing better BER

performance, we should balance the SNR of every substream. The optimal matrix \mathbf{U}_{opt} , which can make the SNRs of different substreams approximately equal, would provide a room for balancing the SNRs of the substreams to maximize the overall BER performance. And we should note that the unitary perturbation can affect the performance of the codebook with linear receivers (ZF, MMSE), but it has no impact on the ML receiver.

Next is the method to construct the subcodebook matrix \mathbf{U}_g . The Fourier based perturbation matrices, used in the second part of the codebook, can be designed as follows:

$$\mathbf{U}_g = \Lambda_g \mathbf{D}_L, g = 0, 1, \dots, G-1 \quad (10)$$

where \mathbf{D}_L is the normalized DFT matrix to be given in (12), and Λ_g is the rotation diagonal matrix to be given in (13), L is the number of layers and G is the total number of \mathbf{U}_g .

$$\mathbf{D}_L = \{d_{kl}, k, l = 0, \dots, L-1\}, d_{kl} = \frac{1}{\sqrt{M}} \exp\left(\frac{j2\pi kl}{M}\right) \quad (11)$$

$$\Lambda_g = \text{diag}\left(1, \exp\left(\frac{j2\pi g}{LG}\right), \dots, \exp\left(\frac{j2\pi(L-1)g}{LG}\right)\right) \quad (12)$$

Finally, like main codebook, we should discuss the codeword search scheme for subcodebook. From the design of the subcodebook, we can see that the search of the subcodebook should rely on the search of main codebook in addition to the channel matrix. Since we construct the subcodebook based on BER improvement, the selection criterion for the second codeword can be expressed as:

$$\mathbf{U}_{opt} = \arg \min_{\mathbf{U} \in \mathcal{C}} \max_{1 \leq k \leq L} \left(\left[\mathbf{U}^H \left(\mathbf{I}_L + \frac{1}{N_0} \mathbf{K}_p^H \mathbf{H}^H \mathbf{H} \mathbf{K}_p \right)^{-1} \mathbf{U} \right]_{kk} \right) \quad (13)$$

3.3. Adaptive selection

In this paper, we have proposed a novel hierarchical codebook in addition. The design of the hierarchical codebook with Fourier based perturbation is to balance the SNRs of different substreams and make the SNRs of different data substreams in the precoding system approximately equal. So when the SNR of each substream have big difference, massive MIMO system would have remarkable performance gain through using subcodebook. However, under the condition where the SNRs of different substreams have little difference, the second part of the codebook(subcodebook) makes little sense on the precoding performance. Thus, it is unnecessary to feedback the PMI of the second part. For this reason, we proposed an adaptive hierarchical selection algorithm according to the substream SNRs. In order to mark the codebook we use, we define a bit

Table 2. Simulated Codebook Type Selection Algorithm

Function GetCTI (SNR[], L)
//L: the number of substreams
//ε: the fixed threshold set previously
//CTI: codebook type indicator
CTI = 0
for $i = 0 : L - 1$
for $j = 0 : L - 1$
if $\text{SNR}[i] - \text{SNR}[j] > \varepsilon$ then
CTI = 1
break
end if
end for
end for
return CTI

variable named Codebook Type Indicator (CTI). Firstly, we compute the difference between any two SNRs of spatial multiplexing streams. Then if all the differences is lower the fixed threshold that we set previously, the CTI will be set as 0, which means we will only use the Kerdock codebook; otherwise, we will use the hierarchical codebook with Fourier based perturbation. Through this method, we can save some feedback overhead. The pseudo code of this adaptive algorithm is shown in Table 2.

4. Numerical Results

In this section, we present some simulation results in the configuration of $N_t = 32, N_r = 3$. The independent and identically distributed (*i.i.d.*) Rayleigh flat fading channels are assumed. Besides, receiver is able to acquire the perfect channel information, and the ZF method is adopted for equalization. The size of the proposed hierarchical codebook is denoted as $[N, G]$, where N and G are the size of the main codebook and the perturbation subcodebook respectively. For this antenna deployment, we have $N = 1024, G = 8$.

Fig. 2 and Fig. 3 show the curves of BER performance for different codebooks under the conditions with little and great SNR differences of different data substreams, respectively. The SNR in the x-axis denotes the average SNR of all the streams. For the purpose of comparison, we also present the BER performance under the ideal condition with the perfect CSI, as well as under the worst condition without precoding.

From Fig. 2, we can see that the proposed codebook has little BER performance gain compared with the original Kerdock codebook, since in most cases only the main codebook is used due to little SNR differences among the substreams. While in Fig. 3, we add

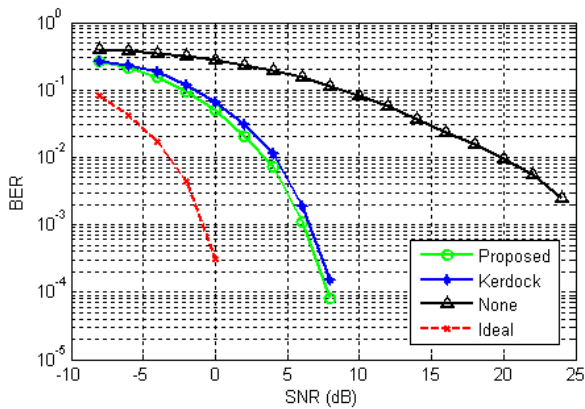

Figure 2. The BER Performance of Different Codebooks (little SNR differences)

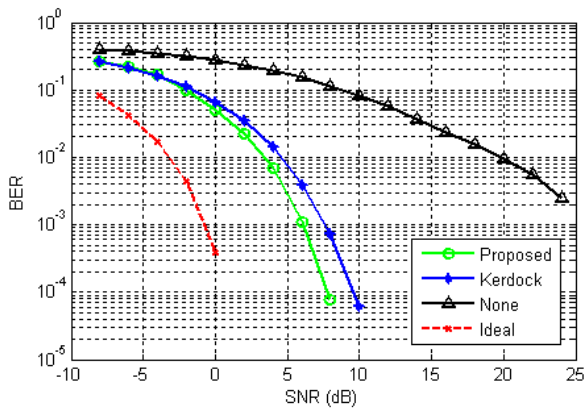

Figure 3. The BER Performance of Different Codebooks (great SNR differences)

different powers of noise for different substreams. It is shown that the proposed codebook has significant BER performance gain since the Fourier-based perturbation subcodebook make a difference.

5. Conclusion

In this paper, we proposed a hierarchical codebook for the massive MIMO system. We adopt the Kerdock codebook as the main codebook of the hierarchical codebook due to its low requirement for storage and selection computational complexity. To balance the SNR differences among different data substreams, thus getting higher precoding performance, we adopt the Fourier-based perturbation matrices as the subcodebook. In addition, for the purpose of compromise

between the system performance and feedback overhead, we proposed an adaptive selection algorithm to reduce the feedback overhead and search complexity without noticeable precoding performance degradation. Simulation results show that compared to the Kerdock codebook, the proposed codebook has significant performance gain, especially under the condition with large SNR differences among substreams.

Acknowledgements. This work was supported by National S&T Major Project (No.2013ZX03001-001), China 863 Project (No. 2012AA011402), Sino-Swedish Strategic Cooperative Programme (No. 2012DFG12010) and National Basic Research Program of China(No. 2013CB329002).

References

- [1] RUSEK F., PERSSON D., LAU B. K., and TUFVESSON F., "Scaling up MIMO: opportunities and challenges with very large arrays," *IEEE Signal Processing Magazine*, pp. 1-44, Oct. 21, 2011.
- [2] INOUE T. and HEATH R. W., "Kerdock codes for limited feedback precoded MIMO systems," *IEEE Trans. Signal Process.* vol. 57, no. 9, pp. 3711-3716, 2009.
- [3] ROH J. and RAO B., "Design and analysis of MIMO spatial multiplexing systems with quantized feedback," *IEEE Trans. Signal Process.* vol. 54, no. 8, pp. 2874-2886, 2006.
- [4] LOVE D. J. and HEATH R. W., "Limited feedback unitary precoding for spatial multiplexing systems," *IEEE Trans. Inf. Theory*, vol. 51, no. 8, pp. 2967-2976, 2005.
- [5] LOVE D. J. and STROHMER T., "Grassmannian beamforming for multiple-input multiple-output wireless systems," *IEEE Trans. Inf. Theory*, vol. 49, no. 10, pp. 2735-2747, 2003.
- [6] RAGHAVAN V., HEATH R. W., and SAYEED A. M., "Systematic Codebook Designs for Quantized Beamforming in Correlated MIMO Channels," *IEEE Journal on Selected Areas in Commun.*, vol. 25, no. 7, pp. 1298-1310, 2007.
- [7] RYAN D. J., VAUGHAN I., CLARKSON L. and HONIG M.L., "QAM codebooks for low-complexity limited feedback MIMO beamforming," in *Proc. IEEE Int. Conf. Commun.*, pp. 4162-4167, 2007.
- [8] 3GPP TS 36.211: Evolved Universal Terrestrial Radio Access (E-UTRA); Physical channels and modulation.
- [9] KLAPPENECKER A. and ROETTEL M., "Constructions of mutually unbi-ased bases," *Finite Fields Appl.*, pp. 137-144, 2004.
- [10] HEATH R. W., STROHMER T. and PAULRAJ A. J., "On quasi-orthogonal signatures for CDMA systems," *IEEE Trans. Inf. Theory*, vol. 52, no. 3, pp. 1217-1226, 2006.
- [11] HUANG Y., XU D. and YANG L., "Limited Feedback Precoding Based on Hierarchical Codebook and Linear Receiver," *IEEE Trans. on Wireless Commun.*, vol. 7, no. 12, pp. 4843-4848, 2008.