

# Multisensory Piano Rehabilitation System

Erikton Konomi, Ian J. Carle, Eric Gouveia, Joseph F. Santacroce, and Douglas E. Dow

Dept. of Electrical Engineering and Technology

Wentworth Institute of Technology, Boston, MA 02115, USA

dowd@wit.edu

## ABSTRACT

Hand function may become impaired due to many factors. Physical therapy may help to improve hand motor function. Multisensory feedback combined with the task of generating music on a keyboard may result in enhanced recovery. This project designed and assembled a prototype system for instructor led training of pressing notes on a keyboard. The keyboard was segmented, such that the lower half of the keys were the instructor side, and the upper half of the keys were the student side. As the instructor played a key, an LED on the corresponding key on the student side would light up to give a visual indicator of what note to play. The auditory tone resulting from the key press would also reflect what note the instructor pressed, and if the student pressed the correct corresponding note, the same tone would be generated. Otherwise, no tone would be generated, indicating an incorrect key press. Both the instructor and student wore gloves with the purpose of detecting what finger the instructor was using to press the key, so that the corresponding finger in the glove of the student would vibrate. This vibration would provide haptic feedback to help the student know what finger to use to press the target key. The system provided visual, audio and haptic feedback to the student to aid instructor led playing of one or of a sequence of keys on a piano keyboard. The next steps of the project are to test the system with instructors and students. If the system works sufficiently, the system could be used to test the effects of the multisensory feedback on any improvements in motor learning and motor function.

## Categories and Subject Descriptors

B.4.2 Input/Output Devices, H.5.2 User Interfaces, H.5.5 Sound and Music Computing, J.3 LIFE AND MEDICAL SCIENCES, K.3.1 Computer Uses in Education

## General Terms

Human Factors

## Keywords

Music, learning, physical therapy, neural rehabilitation, instructor assisted, haptic feedback, visual feedback

## 1. INTRODUCTION

Motor function of the hand can become impaired due to stroke, cerebral palsy, Parkinson's disease, multiple sclerosis, dystonia, other diseases and trauma. Keyboards and repetitive keystrokes have been used to assess hand motor function for cerebral palsy [10] and Parkinson's disease [9]. Playing a musical instrument,

such as the piano keyboard, has been used to investigate motor control of hand function [3, 11], and for assessment of focal dystonia [2]. Not only are keyboard motions useful to assess motor function, but musical beat and rhythm may provide sensory input that enhances motor function and learning. Rhythm and audio cues during training sessions was shown to facilitate premotor cortex function and improve gait motor function in Parkinson's disease and stroke patients [1]. Even patients who are not primarily interested in learning how to play music on instruments, such as piano keyboards, may benefit from the effect of music on mood, motivation, rhythm and tone. The rhythm, music, interaction and multisensory feedback may also result in increased engagement with the therapy by the patient, and thus enhance outcome.

Multisensory input may improve training of hand function and learning of skills, such as music playing. Vibrations presented to the skin can provide information in sensory substitution systems [8]. Vibrational haptic feedback training has helped improve motor control of finger force in multiple sclerosis patients [7]. Vibrational haptic feedback has also been utilized to enhance musical motor learning for percussion [5] and piano [6] instrument playing. Visual and Audio cues can also aid learning of motor function. Audio tone and tempo feedback enhanced control of motor function in piano playing [4].

The objective of this project was to design, assemble and test a keyboard training system that uses multisensory feedback that could be used in training sessions to help a patient perform motor function to mimic the keys a therapist plays on the same keyboard. Both therapist and patient wear gloves during playing the keyboard, and the patient receives visual, audio tone and vibrational haptic feedback to aid the motor function learning task of playing the keys in the context of a musical experience. This multisensory musical therapy may enhance the rehabilitation process for many patients.

## 2. MATERIALS AND METHODS

A block diagram of the prototype system is shown in Figure 1. A standard MIDI keyboard was obtained and modified for the project. Key press information was sent as Musical Instrument Digital Interface (MIDI) to a microcontroller unit (Teensy Arduino board). The microcontroller ran custom software with the following functions. Based on keyboard MIDI key press information, an appropriate piano tone was generated from the microcontroller and played through the audio speaker. A LED on the keyboard was also turned on as explained below. The microcontroller also received information from the therapist (or instructor's) glove to indicate what finger was being used to press the key. The microcontroller then sent signals to activate vibrators in the corresponding fingers of the patient (or student's) glove.

Usage of the keyboard differed from conventional utilization of piano keyboards in the following ways. The lower half (keys on the left side) of the keyboard were to be used by the therapist, acting as the piano instructor. The upper half (keys on the right side) of the keyboard were to be used by the patient, acting as the piano student.

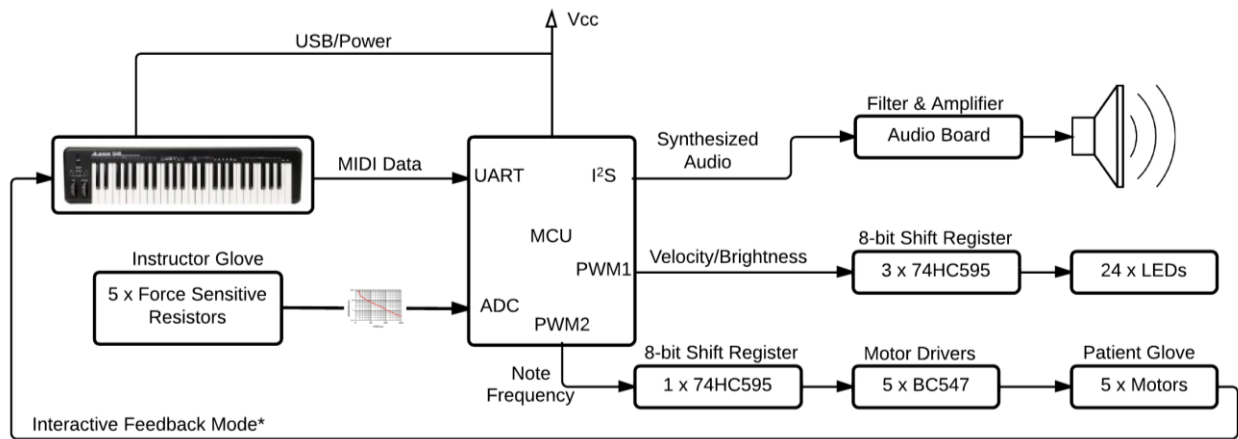
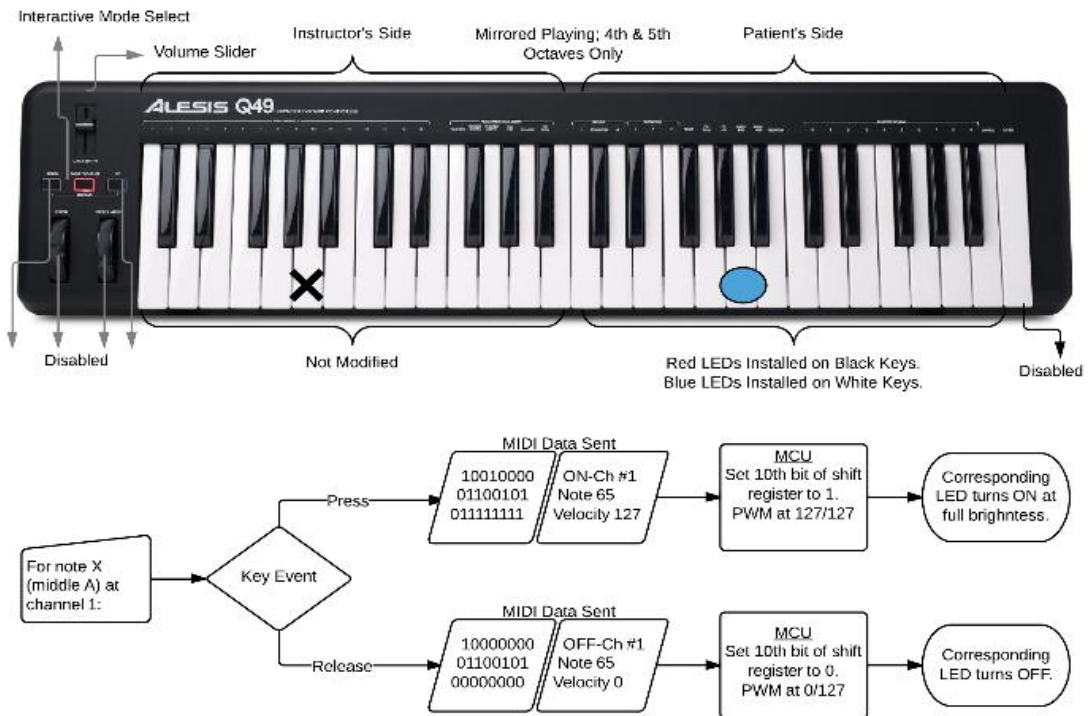

**Figure 1. System Block Diagram.** The keyboard was segmented, such that the lower half (left) was for the instructor and the upper half (right) was for the student. A key press on the lower half (by instructor) resulted in a MIDI signal being passed to a microcontroller (MCU) that interpreted the signal, and output control signals to an audio board to generate suitable tone (volume and pitch). Simultaneously, the microcontroller determined which finger the instructor used to press the key by force sensors in a glove worn by the instructor. The microcontroller then output signals to light an LED embedded in the key that the student is to press, and output signals to vibrate the finger in the glove of student to indicate which finger is to be used.

Each key on the lower half had a corresponding key on the upper half. The musical tone was the same for the two corresponding keys. That is, a tone was generated when the instructor pressed one key. If the student then correctly pressed the corresponding key in the upper half, the same tone would be generated. No tone would be generated if the student pressed the wrong note that did not correspond to the note being played by the instructor. This absence

of sound was intended to provide immediate feedback to the student that the wrong key was pressed.

Visual feedback was provided by LEDs that would light up on the target key. An LED was embedded into each key in the upper half of the keyboard where the student was to play. For the prototype, a



**Figure 2. Keyboard function for key LED activation.** The microcontroller (MCU) interpreted MIDI key event signals to determine the output signals to light the corresponding LED. For example, if key 'A' (of instructor half marked with X) was pressed, then microcontroller output signals to light the LED in corresponding key 'A' (of student half marked with circle). Each black or white key of student half of keyboard had an LED embedded into the key.

hole was drilled into the white and black keys, and LED's were inserted into these holes. Blue LEDs were inserted into the white keys, and red LEDs were inserted into the black keys. Wires to each LED for power and control were hidden under the keyboard, and connected to the main circuit board via a DB-25 cable. As shown in Figure 2, if the instructor pressed the piano 'A' key marked with a black X in the lower half of the keyboard, then the LED in the corresponding piano 'A' key in the upper half of the keyboard would light up. This key, with the lit up LED, is marked with a blue oval in Figure 2. This visual cue of an LED on the target key being lit up was meant to help the student know and learn which key to press.

This function to control the LEDs was implemented as follows. A key press by the instructor in the lower half of the keyboard resulted in a specific MIDI message being sent to the microcontroller. Each MIDI message was decoded by the microcontroller. The microcontroller then determined the corresponding key in the upper half of the keyboard, and sent control signals to turn on that specific LED. Each key on the instructor half of the keyboard activated a corresponding LED on the student half.

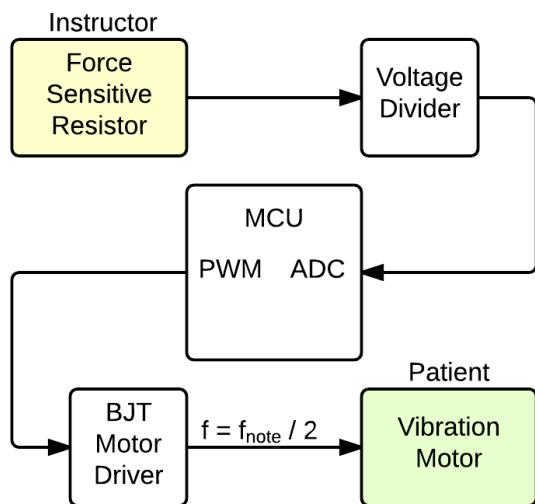
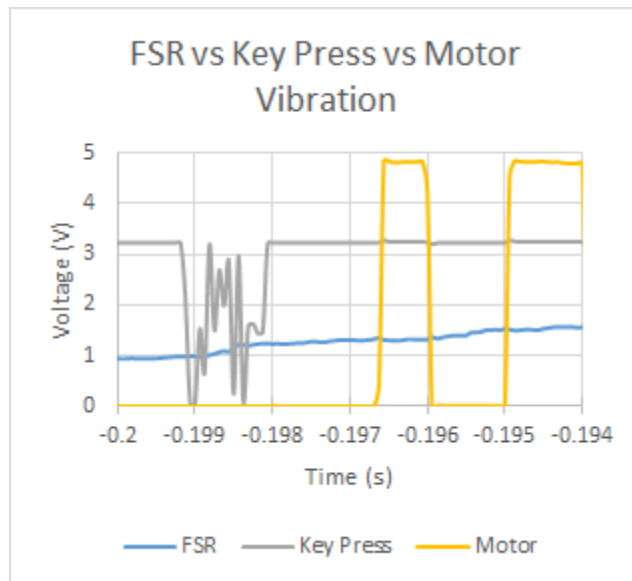

**Figure 3. Diagram for sensor (FSR) in one finger of the instructor's glove that would be detected by the microcontroller (MCU). Then, signals would be sent to the corresponding finger in the student's (patient's) glove to cause vibrations in that finger, helping the student know which finger should be used to press the target key. Each finger would have a similar circuit, with only one MCU for all the fingers.**

The corresponding keys were made to generate the same tone in a similar fashion. The tone that was originally supposed to be generated by a key in the upper half of the keyboard was replaced with the tone of the corresponding key in the lower half of the keyboard by the microcontroller. The result was two duplicate half-keyboards, allowing the instructor and student to each play corresponding keys that generated the same tones.

In addition to the visual feedback of the LED and the audio feedback of the tone, vibrational haptic feedback was provided to aid the student to know which finger was supposed to press on the target key. To implement this function, two gloves were employed: one for the instructor to detect which finger was being used to press the key on the keypad and the other for the student. The finger that the student was supposed to use would vibrate.

The glove for the instructor was made cloth, with force sensitive resistors (FSR) sewn into each fingertip. Each FSR was connected by wires within a cable to the microcontroller. When the microcontroller determined from the MIDI signal that a key was being pressed on the instructor side of the keyboard, the microcontroller would then analyze the signals from the FSRs of the instructor's glove to determine which finger of the instructor was pressing the key. Then the microcontroller would send control signals to a small motor that would vibrate the corresponding finger in the glove of the student.



**Figure 4. Example of signals that were recorded to observe the time delay between key press-related indicators and resulting vibration of motor in student glove finger. The transient changes in the trace marked "Key Press" indicate when a key had been pressed and a MIDI message was output from the keyboard to the microcontroller. The sudden rise in the trace marked "Motor" indicated the output signal from the microcontroller to drive the motor in the student glove finger to vibrate. A delay for just over 2 ms was observed in this figure between the start of the MIDI message and the start of the motor vibration signal. The trace marked "FSR" indicated changes in force detected at the fingertip pressing the key. In contrast to the more bi-stable behavior of the key press and control signal to the motor, the force signal reflected a more continuous change in force as the finger pushes on the key.**

The prototype glove for the student consisted of an open faced glove with Velcro straps on the fingers. This open design was intended to allow placement around the hand, even if some deformation, swelling or stiffness existed. The glove incorporated one variable speed motor in each digit near the glove fingertip. These motors were controlled by the microcontroller through wires in a cable. The purpose of this glove was to provide the haptic feedback to the patient, in the form of vibrations on the tip of the patient's fingertip. These vibrations reflected the intensity and frequency of the notes played by the instructor. Figure 3 shows a diagram for one finger of each of the gloves, and how the microcontroller obtained finger press information from the instructor glove and then generated vibrations in the corresponding finger in the student's glove.

### 3. RESULTS

The design was assembled in a prototype system. Preliminary tests were conducted by able-bodied volunteers to assess basic function of the system. From the MIDI signals, the microcontroller determined the starting and ending time of each key press by the instructor on the lower half of the keyboard. The start and end times were used to start and end both the signals that turned on the corresponding LED on the upper half of the keyboard for the student and that vibrated the corresponding finger in the student's glove. The microcontroller would also interpret the force of the key press from the MIDI signal, and regulate both the volume of the tone and the brightness of the corresponding LED. The greater the force, the louder the tone and the brighter the LED. The tone generated by the key press on the lower half was the same as the tone generated by a key press of the corresponding key on the upper half.

Long or irregular delays between instructor key press and feedback for the student (light up LED and vibrate finger in the glove) would hinder timely and reliable feedback to the student. Thus, timing between these events was assessed using an oscilloscope.

Two sets of measurements were made, between the key press and the corresponding motor vibration and also between the FSR (force sensitive resistor) and the corresponding motor vibration, using five different keys (notes) and three fingers (thumb, index and middle). Example traces from an oscilloscope are shown in Figure 4.

The two data sets are summarized Table 1 and Table 2.

**Table 1. Time Delay from Key Press to Motor Vibration (ms)**

Note	C4	C#4	C5	A#5	B5	Avg
Thumb	2.62	2.44	2.38	2.76	2.38	2.52
Index	2.34	2.46	2.36	2.74	2.46	2.47
Middle	2.78	2.34	2.42	2.40	2.64	2.52
Avg	2.58	2.41	2.39	2.63	2.49	2.50

**Table 2. Time Delay from FSR to Motor Vibration (ms)**

Note	C4	C#4	C5	A#5	B5	Avg
Thumb	18.7	44.6	33.3	22.2	51.9	34.1
Index	39.0	39.1	55.1	34.2	65.7	46.6
Middle	69.6	40.5	30.9	41.7	26.0	41.7
Avg	42.4	41.4	39.8	32.7	47.9	40.8

The delay between the key press on the instructor side of the keyboard and motor vibration in the glove of the student was about 2.5 ms (Table 1). A larger delay of about 40.8 ms was observed between the detection in increasing force in the glove of the instructor and the motor vibrations. One explanation for the larger delay is the FSR detected force being applied to the fingertip before the key actually resulted in the key being displaced (pressed) down, and detected by the keyboard system. Thus the delay within the system appears to be at an acceptable level compared to human monitoring of the feedback signals.

### 4. DISCUSSION

The preliminary tests seem to indicate the system functions as designed. The next step would be to test this function with able bodied instructors and students. Later to test with students having

some impairment in hand motor function. If this testing shows the system functions with these types of students, then the system might be ready evaluating the effects of audio, visual and haptic feedback on student learning of a series of music notes, and on any improvement in motor function after a period of training.

### 5. REFERENCES

- [1] Chen, J. L., Zatorre, R. J. and Penhune, V. B. Interactions between auditory and dorsal premotor cortex during synchronization to musical rhythms. *Neuroimage*, 32, 4 (Oct 1 2006), 1771-1781. DOI=S1053-8119(06)00506-4 [pii].
- [2] Furuya, S. and Altenmuller, E. Finger-specific loss of independent control of movements in musicians with focal dystonia. *Neuroscience*, 247(Sep 5 2013), 152-163. DOI=10.1016/j.neuroscience.2013.05.025 [doi].
- [3] Furuya, S., Flanders, M. and Soechting, J. F. Hand kinematics of piano playing. *J. Neurophysiol.*, 106, 6 (Dec 2011), 2849-2864. DOI=10.1152/jn.00378.2011 [doi].
- [4] Furuya, S. and Soechting, J. F. Role of auditory feedback in the control of successive keystrokes during piano playing. *Exp. Brain Res.*, 204, 2 (Jul 2010), 223-237. DOI=10.1007/s00221-010-2307-2 [doi].
- [5] Grindlay, G. Haptic guidance benefits musical motor learning. In Anonymous Haptic interfaces for virtual environment and teleoperator systems, 2008. *Haptics 2008. symposium on. IEEE*, 2008, 397-404.
- [6] Huang, K., Do, E. and Starner, T. PianoTouch: A wearable haptic piano instruction system for passive learning of piano skills. In *Anonymous Wearable Computers, 2008. ISWC 2008. 12th IEEE International Symposium on. IEEE*, 2008, 41-44.
- [7] Jiang, L., Cutkosky, M. R., Ruutiainen, J. and Raisamo, R. Improving finger force control with vibrational haptic feedback for multiple sclerosis. In *Anonymous Proceedings of the IASTED International Conference on Telehealth/Assistive Technologies. ()*. ACTA Press, 2008, 110-115.
- [8] Kaczmarek, K. A., Webster, J. G., Bach-y-Rita, P. and Tompkins, W. J. Electrotactile and vibrotactile displays for sensory substitution systems. *IEEE Trans. Biomed. Eng.*, 38, 1 (Jan 1991), 1-16. DOI=10.1109/10.68204 [doi].
- [9] Noyce, A. J., Nagy, A., Acharya, S., Hadavi, S., Bestwick, J. P., Fearnley, J., Lees, A. J. and Giovannoni, G. Bradykinesia-Akinesia Incoordination Test: Validating an Online Keyboard Test of Upper Limb Function. *PLoS ONE*, 9, 4 (04 2014), 1-9. DOI=10.1371/journal.pone.0096260.
- [10] Steenbergen, B., Veringa, A., haan, A. d. and Hulstijn, W. Manual dexterity and keyboard use in spastic hemiparesis: a comparison between the impaired hand and the 'good' hand on a number of performance measures. *Clin. Rehabil.* 12, 1 (02 1998), 64-72.
- [11] Winges, S. A., Furuya, S., Faber, N. J. and Flanders, M. Patterns of muscle activity for digital coarticulation. *J. Neurophysiol.*, 110, 1 (Jul 2013), 230-242. DOI=10.1152/jn.00973.2012 [doi].