

MagTag - A Wearable Wrist Device for Localization Applications

Ultra Small, Hospital Compliance and Wireless Recharging

S. Silva, P. M. Mendes
University of Minho
Braga, Portugal

L. Domingues
Noniussoft S.A
Porto, Portugal

Abstract—Ambient assisted living is a technology aiming to improve the people's quality of live. Despite the well known benefits of this technology, its acceptance requires wearable devices, which must be small, lightweight, and with power autonomy enough for comfortable operation. This paper presents the smallest localization device known for using on localization applications, based on a Wi-Fi infrastructure. This module was designed to fulfill clinical environment compliance. This requires a hermetically sealed module with clinically compatible materials. Since it is to be worn as a wrist clock, wearability and fashionable design were taken into account. Moreover, for easiness of use and cleaning, the module uses wireless recharging technology. Any conference participant will be allowed to test the localization ability and the wearability of this module.

Keywords—Localization; wireless power; wearable device

I. INTRODUCTION

Ambient assisted living (AAL) is a technology aiming to improve the people's quality of live [1]. One well known requirement in ambient assisted living solutions is the ability to track someone inside an environment, using the already deployed wireless infrastructure. Several wireless AAL solutions for monitoring have been proposed in the past few years, e.g. [2, 3]. One solution is to use the Wi-Fi infrastructure and deploy small modules, worn by the subject under monitorization. Then, using the Wi-Fi network infrastructure, the module can be used for tracking purposes.

This demo will show a system that enables localization of a walking user inside a building, using a device that was developed to be used as a wrist clock. In this way, and to reduce the deployment costs, the localization technology is based on the installed Wi-Fi network, and therefore the localization device must use a Wi-Fi module. The designed module uses a "component over the shelf" low power Wi-Fi module.

The tag communicates with existing WLAN infrastructure in order to help control centers to keep track of their subjects under monitorization. A key feature of this device was a waterproof capability and the requirement for simple cleaning methods. In this way, a wireless recharging capability was implemented, which is able to fully recharge the battery when the module is placed on a base station for around two hours.

Moreover, as onboard sensors, it has a motion detector and a photonic wrist removal detector.

Since the localization device was designed to be worn on the subject wrist, the module should not largely exceed the dimensions of a wrist clock. Fig. 1 shows the developed module.



Figure 1. Magtag, side-by-side with a wrist clock.

II. MODULE DESIGN

The technology under demonstration was developed taking into account case design, and electronics and software design.

A. Module Case

Since this module must be able to operate inside clinical environments, all the materials were selected to comply with that. Also, since the localization is only possible when the subject is wearing the module, special attention was paid to the module attachment to the wrist. It should be comfortable, and at the same time resistant to removal. At the same time, it should be possible to place the module easily and the module must be easily cleaned. These characteristics will be shown at the demo session.

B. Electronics

Fig. 2 shows the module architecture implemented. This device is based on a low power and small form factor Wi-Fi

core. The onboard sensors include hardware sensors, e.g., to detect the subject movement or to detect if the module is removed from the wrist, and software sensors, e.g., to detect the subject localization. The battery module includes a sub-module, which is one main feature of this technology that allows wireless battery recharging.

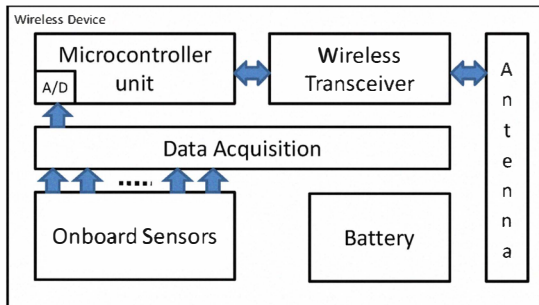

Figure 2. Wireless localization device architecture.

C. Localization

Fig. 3 shows a software module, with the localization of a subject moving inside a building.

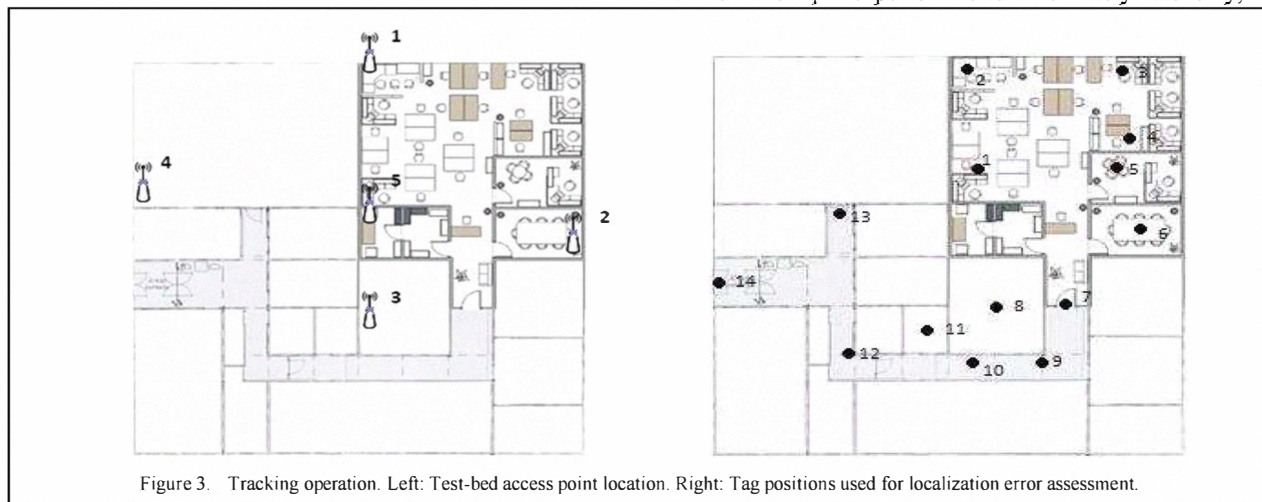

Figure 3. Tracking operation. Left: Test-bed access point location. Right: Tag positions used for localization error assessment.

This interface is customizable for each application needs. Besides the localization facility, it may also include other features as alarms, e.g., to indicate when the subject is out of range, out of a predetermined area, or with low battery.

III. TEST AND MEASUREMENTS

Since the module was expected to be as small as possible the platforms under test were powered by a 150 mAh, 3.7 V, 20x30x4.0 mm³ Li-ion battery. However, the indicated supply battery may change, due to different autonomy constraints.

A. Localization Ability

Initial tests showed a resolution of 2 to 5 meters (90% of the time) for an indoor environment. Those tests showed that the tag meets the project requirements. The obtained performance makes the tag viable for all the expected project scenarios, namely in the Hospitals and Healthcare markets.

B. Module autonomy

All the tests were made using a small resistor in series with the battery, and the voltage drop was measured. From that, the current consumption was extracted. Using this procedure, the following results were obtained.

TABLE I. WiFi MODULE POWER CONSUMPTION

Operating Mode	Current consumption	
	Measured ($V_{cc}=3.3V$)	Expected
Tx mode	270 mA @ 18 dBm	212 mA @ 18 dBm
Rx mode	50 mA	40 mA
Sleep mode	1.5 mA	6 μ A

At the moment, this device is used only for localization purposes. Under normal operating mode, the device is sleeping for 20 s, then awakes, detects its position, and sends it to a nearby wireless access point.

From the table, it can be observed that during transmission the current measured value exceeds the expected by about 60 mA. Also, in sleep mode, the current measured was 1.5 mA, far from the 6 μ A expected. To test the battery autonomy, a 6

seconds transmission interval was used and the battery life was 20 hours. All these tests were made with all the active sensors turned off.

IV. CONCLUSIONS

This demo will allow any conference participant to test the localization ability and the wearability of this module, including conference staff.

REFERENCES

- [1] Ambient Assisted Living Joint Programme Europe at www.aal-europe.eu (Available December 2009)
- [2] Varshney, U. "Pervasive Healthcare and Wireless Health Monitoring", *Mobile Newt Appl*, vol.12, pp. 113-127, July 2007.
- [3] Pantelopoulos, A., Bourbakis, N., "A Survey on Wearable Biosensor Systems for Health Monitoring", *IEEE EMBS 2008 Conference*, pp. 4887-4890, August 2008.