

RF-Aware Widely-Linear Beamforming and Null-Steering in Cognitive Radio Transmitters

Aki Hakkarainen*, Janis Werner*, Kapil R. Dandekar[†] and Mikko Valkama*

*Department of Electronics and Communications Engineering

Tampere University of Technology, P.O. Box 553, FI-33101 Tampere, Finland

Email: {aki.hakkarainen, janis.werner, mikko.e.valkama}@tut.fi

[†]Department of Electrical and Computer Engineering

Drexel University, Philadelphia, PA 19104, USA

Email: dandekar@drexel.edu

Abstract—Protection of the primary users (PUs) from interference stemming from secondary user (SU) transmissions is one of the key issues in dynamic cognitive radio systems. Assuming elementary direction of arrival (DOA) or location estimation of PU devices can be carried out in the SU devices, appropriate directional transmission utilizing e.g. antenna arrays and null-steering can then be deployed to avoid interference by steering nulls towards the PUs. In this paper, we study such transmitter digital beamforming and null-steering under practical limitations of the associated radio frequency (RF) circuits, namely the amplitude and phase mismatches between the in-phase and quadrature (I/Q) rails of the parallel up-conversion chains. Closed-form analysis of the available beamforming and null-steering capabilities is first provided, showing that the transmitter null-steering capabilities are heavily degraded due to RF circuit imperfections. Motivated by this, we will then propose and formulate a widely-linear (WL) digital beamforming and null-steering solution which is shown to efficiently suppress the RF circuit imperfection effects from the radiation pattern. Based on the obtained results, the developed solution can provide efficient null-steering and interference suppression characteristics, despite of the imperfections in the RF circuits, and can thus enable, e.g., the use of cost-efficient RF chains in the SU transmitters.

I. INTRODUCTION

While most existing and emerging radio communication systems, like mobile cellular networks and broadcast networks, build on heavily regulated radio spectrum use, recent measurement campaigns have revealed (see, e.g., [1]–[5]) that there are big temporal and spatial variations in the truly realized radio spectrum use. This, in turn, indicates that sophisticated or cognitive radio (CR) devices, being able to identify time-, frequency- and/or space-dependent under-utilized chunks of the radio spectrum, could use them in a dynamic manner for communication purposes [6]. Thus the efficiency and flexibility of the overall radio spectrum use would be greatly improved, offering also the possibility of overlay type secondary radio systems.

This work was supported by the Finnish Funding Agency for Technology and Innovation (Tekes) under the project "Reconfigurable Antenna-based Enhancement of Dynamic Spectrum Access Algorithms", the Industrial Research Fund of Tampere University of Technology (Tuula and Yrjö Neuvo Fund), and the Doctoral Programme of the President of Tampere University of Technology.

This work was also supported by the National Science Foundation (NSF) under award number 1147838.

One of the most central requirements in dynamic secondary user (SU) spectrum access systems is the ability to control interference towards primary user (PU) devices. One interesting recently-established idea in this context is to carry out direction of arrival (DOA) and/or location estimation of the PU devices and use that information in the SU access system in controlling the interference. Such ideas have been described at concept, signal processing and network levels, e.g., in [7]–[9]. At physical layer, one interesting possibility is to use novel reconfigurable antenna systems, like transmitter null-steering through digital beamforming [10] or leaky-wave antenna (LWA) structures [11], for directional transmission such that interference towards identified PU devices is minimized.

In this paper, motivated by the ever-increasing digital signal processing capabilities in radio devices, we focus on digital beamforming based transmitter null-steering and the associated radio frequency (RF) hardware challenges in SU transmitters. Assuming that the parallel RF chains deploy the well-known direct-conversion transmitter (DCT) topology [12], known to suffer from the amplitude and phase mismatches between the I and Q rails of the individual RF chains [13], we will first provide closed-form radiation pattern analysis of the overall transmitter including the effects of such practical RF imperfections. The analysis shows that the beamforming capabilities, and especially the null-steering performance, are heavily degraded due to the imperfections in the transmitter RF circuits. This is especially emphasized when the number of antennas is fairly high and thus high angular resolution is targeted. Stemming from this, we will then formulate and propose an augmented or widely-linear (WL) signal processing based beamforming solution which has the structural capability to automatically suppress the effects of the practical RF circuit imperfections. Optimum RF-aware widely-linear beamforming coefficients are derived and demonstrated through extensive simulations to yield beamforming and null-steering performance practically identical to the case with ideal RF circuits. Thus based on the obtained results, the proposed RF-aware beamforming principle can offer high-performance null-steering and physical layer interference protection solution, despite of practical limitations in the deployed RF circuits. This can then enable the use of cost-efficient RF circuits in

the SU devices without sacrificing the interference control capabilities towards PUs.

The rest of the paper is organized as follows. In Section II, the fundamental array signal and system models, including also I/Q imbalance models and WL processing, are provided. Then, in Section III, the classical linear null-steering method is reviewed and based on that, the proposed RF-aware WL null-steering beamforming is formulated. Next, in Section IV, simulations and numerical results are given for illustrating the capabilities of the conventional and proposed WL null-steering methods under RF I/Q imbalance. Finally, the paper is concluded in Section V.

Notation: Throughout the paper, vectors and matrices are written with bold characters. The superscripts $(\cdot)^T$, $(\cdot)^H$, $(\cdot)^*$ and $(\cdot)^{-1}$ represent transpose, hermitian (conjugate) transpose, conjugate and matrix inverse, respectively. The tilde sign \sim above variables is used to present a WL (augmented) quantity and the results obtained by the WL processing.

II. FUNDAMENTAL SIGNAL AND ARRAY MODELS

A. Spatial Response of Transmitter Beamformer

The digital baseband signal snapshots $\mathbf{x} = [x_1, x_2, \dots, x_N]^T \in \mathbb{C}^{N \times 1}$ in a transmit beamformer with N antenna elements can be presented as

$$\mathbf{x} = \mathbf{w}(\theta_d)s \quad (1)$$

where $\mathbf{w}(\theta_d) = [w_1(\theta_d), w_2(\theta_d), \dots, w_N(\theta_d)]^T \in \mathbb{C}^{N \times 1}$ refers to the precoding weights under a given optimization criteria towards the desired direction θ_d [14]. In addition, s is the transmitted complex signal snapshot. The conceptual digital transmit beamformer and the used notation is depicted in Fig. 1. When the transmitted signal snapshots are eventually received by the receiver located in direction θ , the corresponding received snapshot is equal to

$$y(\theta) = \mathbf{a}^H(\theta)\mathbf{x} + n = \mathbf{a}^H(\theta)\mathbf{w}(\theta_d)s + n \quad (2)$$

where $\mathbf{a}(\theta) \in \mathbb{C}^{N \times 1}$ is the steering vector and n denotes the additive white Gaussian noise (AWGN) due to the transmission channel and receiver equipment. Here, the noise is assumed to be complex circular. Note that we have excluded the actual propagation related effects in (2) since with closely-spaced antenna elements, the effective channels between different transmit antennas and the receiver only differ by the phase shifts included in $\mathbf{a}(\theta)$. The steering vector of the transmitter is defined e.g. for a uniform linear array (ULA) as $\mathbf{a}(\theta) = [1, e^{j d \kappa \cos \theta}, e^{j 2 d \kappa \cos \theta}, \dots, e^{j (N-1) d \kappa \cos \theta}]^T$. Here, $\kappa = \frac{2\pi}{\lambda}$ where λ is the wavelength of the RF signal frequency. Further, the signal power in the receiver is given by

$$\mathbb{E} \left[|y(\theta)|^2 \right] = \sigma_s^2 |\mathbf{a}^H(\theta)\mathbf{w}(\theta_d)|^2 + \sigma_n^2 \quad (3)$$

where $\sigma_s^2 = \mathbb{E} [|s|^2]$ denotes the signal power and $\sigma_n^2 = \mathbb{E} [|n|^2]$ is the noise power. Finally, the spatial response of the transmit beamformer with given precoding weights can be presented as the radiation pattern. It is defined as the spatial

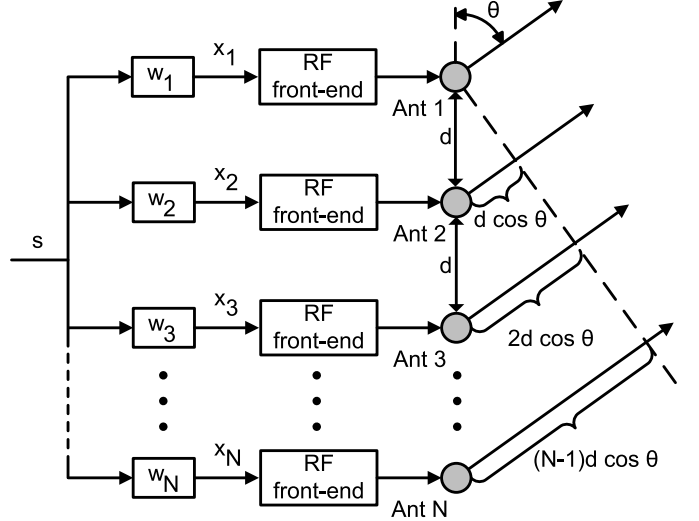

Fig. 1. The conceptual digital transmit beamformer and the used notation.

dependency of the received signal power seen by the receiver located in direction θ . Thus, the radiation pattern is given by

$$D(\theta) = |\mathbf{a}^H(\theta)\mathbf{w}(\theta_d)|^2. \quad (4)$$

B. I/Q Imbalance in Transmitter

DCTs (also known as zero-IF transmitters) up-convert two real-valued baseband signals, namely in-phase (I) and quadrature-phase (Q) signals, straight to the RF frequency [12]. These RF signals are then combined and the resulting RF signal is finally amplified and transmitted through the antenna [15]. Ideally the up-conversion is done with two local oscillators (LOs) and mixers which have equal gains and exactly 90° phase difference. This is unfortunately not the case in practice resulting in gain and phase mismatches between the up-converted RF signals [13]. This effect is known as I/Q imbalance and can be modeled for a single radio chain at baseband equivalent level as [16]

$$x_{\text{imb}}(t) = K_1 x(t) + K_2 x^*(t) \quad (5)$$

where $K_1 = (1 + g e^{j\phi})/2$ and $K_2 = (1 - g e^{j\phi})/2$. In addition, $x(t)$ is the baseband equivalent signal under perfect I/Q matching, and g and ϕ denote relative gain and phase mismatches in the transmitter chain, respectively. Note that the I/Q imbalance creates a WL transformation to the signal which is our main motivation for the WL processing discussed in Section II.C.

In an antenna array transmitter utilizing digital beamforming, several transmitter chains are used in parallel and the corresponding baseband equivalent signal snapshots (one for each transmitter chain) under transmitter I/Q imbalance can be modeled as

$$\begin{aligned} \mathbf{x}_{\text{imb}} &= \mathbf{K}_1 \mathbf{x} + \mathbf{K}_2 \mathbf{x}^* \\ &= [\mathbf{K}_1, \mathbf{K}_2] \begin{bmatrix} \mathbf{w}(\theta_d) & \mathbf{0}_N \\ \mathbf{0}_N & \mathbf{w}^*(\theta_d) \end{bmatrix} \begin{bmatrix} s \\ s^* \end{bmatrix} \end{aligned} \quad (6)$$

where matrices

$$\mathbf{K}_1 = \text{diag}(K_{1,1}, K_{1,2}, \dots, K_{1,N}) \quad (7)$$

$$\mathbf{K}_2 = \text{diag}(K_{2,1}, K_{2,2}, \dots, K_{2,N}) \quad (8)$$

present the I/Q imbalance coefficients of each parallel transmitter chain. The corresponding signal snapshot observed by the receiver in direction θ is then given by

$$\begin{aligned} y_{\text{imb}}(\theta) &= \mathbf{a}^H(\theta) \mathbf{x}_{\text{imb}} + n \\ &= \mathbf{a}^H(\theta) [\mathbf{K}_1, \mathbf{K}_2] \begin{bmatrix} \mathbf{w}(\theta_d) & \mathbf{0}_N \\ \mathbf{0}_N & \mathbf{w}^*(\theta_d) \end{bmatrix} \begin{bmatrix} s \\ s^* \end{bmatrix} + n \\ &= \mathbf{a}^H(\theta) \mathbf{K}_1 \mathbf{w}(\theta_d) s + \mathbf{a}^H(\theta) \mathbf{K}_2 \mathbf{w}^*(\theta_d) s^* + n. \end{aligned} \quad (9)$$

This result means that the received signal is on the one hand corrupted by the common response \mathbf{K}_1 and on the other hand suffers from the self interference due to the complex conjugate term. Since in realistic scenarios $|K_{1,i}| \gg |K_{2,i}| \forall i$ [16] and $|\mathbf{a}^H(\theta) \mathbf{w}(\theta_d)| \gg |\mathbf{a}^H(\theta) \mathbf{w}^*(\theta_d)|$, the self interference term is weak but cannot be neglected, especially with high-order modulations. Actually, the self interference creates a twist to the constellation diagram and the symbol detection in the receiver side becomes more difficult.

To quantify the signal properties further, the power of the received signal under transmitter I/Q imbalance is written as

$$\begin{aligned} \mathbb{E} [|y_{\text{imb}}(\theta)|^2] &= \sigma_s^2 |\mathbf{a}^H(\theta) \mathbf{K}_1 \mathbf{w}(\theta_d)|^2 \\ &\quad + \sigma_s^2 |\mathbf{a}^H(\theta) \mathbf{K}_2 \mathbf{w}^*(\theta_d)|^2 + \sigma_n^2. \end{aligned} \quad (10)$$

In addition, the radiation pattern of the transmit beamformer under I/Q imbalance can be given by

$$D_{\text{imb}}(\theta) = |\mathbf{a}^H(\theta) \mathbf{K}_1 \mathbf{w}(\theta_d)|^2 + |\mathbf{a}^H(\theta) \mathbf{K}_2 \mathbf{w}^*(\theta_d)|^2. \quad (11)$$

It is clear that I/Q imbalance is affecting the radiation properties since the coefficients \mathbf{K}_1 and \mathbf{K}_2 are present in (11). More importantly, the latter term, which is totally new compared to (4), includes conjugated precoding weight $\mathbf{w}^*(\theta_d)$. Interestingly in case of ULAs and equal I/Q imbalance in all transmitter branches, this creates an additional beam to the mirror direction $180^\circ - \theta$ as is shown in Section IV. This is of course a harmful effect and should be suppressed, especially if null-steering towards the mirror-angle is targeted.

C. Widely-Linear Beamforming

WL processing precodes not only the signal s itself but also its complex conjugate s^* with individual weights [17] as follows

$$\tilde{\mathbf{x}} = \mathbf{W}(\theta_d) \tilde{\mathbf{s}} = [\mathbf{w}_1(\theta_d), \mathbf{w}_2(\theta_d)] \begin{bmatrix} s \\ s^* \end{bmatrix}. \quad (12)$$

Here, the weight matrix $\mathbf{W} = [\mathbf{w}_1(\theta_d), \mathbf{w}_2(\theta_d)] \in \mathbb{C}^{N \times 2}$ and the augmented signal vector $\tilde{\mathbf{s}} = [s, s^*]^T \in \mathbb{C}^{2 \times 1}$. Weights $\mathbf{w}_1(\theta_d)$ and $\mathbf{w}_2(\theta_d)$ are the WL precoding weights for the signal snapshot and its complex conjugate, respectively, optimized under a given optimization criteria towards the desired direction θ_d . The conceptual WL digital transmit

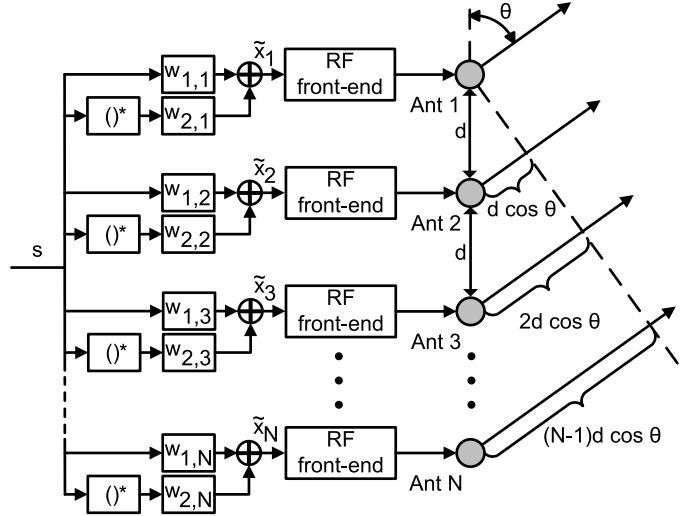

Fig. 2. The conceptual WL digital transmit beamformer.

beamformer is depicted in Fig. 2. The corresponding signal snapshot observed by the receiver in direction θ is equal to

$$\begin{aligned} \tilde{y}(\theta) &= \mathbf{a}^H(\theta) \tilde{\mathbf{x}} + n \\ &= \mathbf{a}^H(\theta) [\mathbf{w}_1(\theta_d), \mathbf{w}_2(\theta_d)] \begin{bmatrix} s \\ s^* \end{bmatrix} + n \\ &= \mathbf{a}^H(\theta) \mathbf{w}_1(\theta_d) s + \mathbf{a}^H(\theta) \mathbf{w}_2(\theta_d) s^* + n. \end{aligned} \quad (13)$$

In case of circular signals, the conjugate of the signal does not include any additional information for the beamforming and thus WL processing does not offer significant performance gain, when perfect RF hardware with perfect I/Q balance is assumed. However, since I/Q imbalance structurally creates WL transformation to the signal, WL beamforming becomes a natural choice for the beamforming problem under I/Q imbalance. It results in doubled computational load (compared to the linear case) but also offers doubled degrees of freedom for the I/Q imbalance mitigation, and makes separate I/Q calibration loops in parallel transmit chains unnecessary.

The baseband equivalent transmit signal snapshots obtained by WL precoding under I/Q imbalance are modeled as

$$\begin{aligned} \tilde{\mathbf{x}}_{\text{imb}} &= \mathbf{K}_1 \tilde{\mathbf{x}} + \mathbf{K}_2 \tilde{\mathbf{x}}^* \\ &= [\mathbf{K}_1, \mathbf{K}_2] \begin{bmatrix} \mathbf{w}_1(\theta_d) & \mathbf{w}_2(\theta_d) \\ \mathbf{w}_2^*(\theta_d) & \mathbf{w}_1^*(\theta_d) \end{bmatrix} \begin{bmatrix} s \\ s^* \end{bmatrix}. \end{aligned} \quad (14)$$

Further, the corresponding signal snapshot observed by the receiver in direction θ is now equal to

$$\begin{aligned} \tilde{y}_{\text{imb}}(\theta) &= \mathbf{a}^H(\theta) \tilde{\mathbf{x}}_{\text{imb}} + n \\ &= \mathbf{a}^H(\theta) [\mathbf{K}_1, \mathbf{K}_2] \begin{bmatrix} \mathbf{w}_1(\theta_d) & \mathbf{w}_2(\theta_d) \\ \mathbf{w}_2^*(\theta_d) & \mathbf{w}_1^*(\theta_d) \end{bmatrix} \begin{bmatrix} s \\ s^* \end{bmatrix} + n \\ &= \mathbf{a}^H(\theta) (\mathbf{K}_1 \mathbf{w}_1(\theta_d) + \mathbf{K}_2 \mathbf{w}_2^*(\theta_d)) s \\ &\quad + \mathbf{a}^H(\theta) (\mathbf{K}_1 \mathbf{w}_2(\theta_d) + \mathbf{K}_2 \mathbf{w}_1^*(\theta_d)) s^* + n. \end{aligned} \quad (15)$$

Still, both s and s^* exist in the received signal but now with a more flexible weighting than in the plain linear case. In fact, with proper transmit weight selection it is now possible to

eliminate the conjugated term completely while preserving the desired term, which is not possible with the linear beamformer.

The power of the received signal under transmit I/Q imbalance is now given by

$$\begin{aligned} \mathbb{E} \left[|\tilde{y}_{\text{imb}}(\theta)|^2 \right] &= \sigma_s^2 \left| \mathbf{a}^H(\theta) (\mathbf{K}_1 \mathbf{w}_1(\theta_d) + \mathbf{K}_2 \mathbf{w}_2^*(\theta_d)) \right|^2 \\ &\quad + \sigma_s^2 \left| \mathbf{a}^H(\theta) (\mathbf{K}_1 \mathbf{w}_2(\theta_d) + \mathbf{K}_2 \mathbf{w}_1^*(\theta_d)) \right|^2 \\ &\quad + \sigma_n^2. \end{aligned} \quad (16)$$

Finally, the radiation pattern of the WL beamformer under I/Q imbalance is equal to

$$\begin{aligned} \tilde{D}_{\text{imb}}(\theta) &= \left| \mathbf{a}^H(\theta) (\mathbf{K}_1 \mathbf{w}_1(\theta_d) + \mathbf{K}_2 \mathbf{w}_2^*(\theta_d)) \right|^2 \\ &\quad + \left| \mathbf{a}^H(\theta) (\mathbf{K}_1 \mathbf{w}_2(\theta_d) + \mathbf{K}_2 \mathbf{w}_1^*(\theta_d)) \right|^2. \end{aligned} \quad (17)$$

Here, the first term presents the power of the wanted signal term whereas the latter term is due to the unwanted conjugated signal term. Therefore, the magnitude of the first term should be maximized (under the maximum output power constraints) while the latter term should be attenuated as much as possible in order to minimize the spurious responses. This will be addressed next, including also additional null-steering constraints towards PUs.

III. RF-AWARE WL NULL-STEERING BEAMFORMING

A. Conventional Null-Steering Method

Beamforming methods which have the wanted response characteristics to the desired direction while minimizing the transmitted power to the forbidden direction(s) (or the received power from the interference source direction), are commonly referred as null-steering beamforming methods [18]–[20]. The conventional null-steering approach for the transmitter side can be formulated as

$$\max_{\mathbf{w}} \left| \mathbf{w}^H \mathbf{a}(\theta_d) \right|^2 \quad \text{subject to} \quad \begin{cases} \mathbf{w}^H \mathbf{A} = \mathbf{0} \\ \mathbf{w}^H \mathbf{w} \leq \sqrt{\alpha} \end{cases} \quad (18)$$

where $\mathbf{A} = [\mathbf{a}(\theta_{\text{PU},1}), \mathbf{a}(\theta_{\text{PU},2}), \dots, \mathbf{a}(\theta_{\text{PU},M})] \in \mathbb{C}^{N \times M}$ is the null-steering matrix consisting of steering vectors for M PU directions [10]. The transmitted power of the array is equal to $\alpha \sigma_s^2$. The classical optimum solution for the optimization task above is given by

$$\mathbf{w}_{\text{NS}} = \frac{\sqrt{\alpha}}{\|(\mathbf{I} - \mathbf{P}_{\mathbf{A}}) \mathbf{a}(\theta_d)\|} (\mathbf{I} - \mathbf{P}_{\mathbf{A}}) \mathbf{a}(\theta_d) \quad (19)$$

where $\mathbf{I} \in \mathbb{C}^{N \times N}$ is an identity matrix and $\mathbf{P}_{\mathbf{A}} \in \mathbb{C}^{N \times N}$, defined as

$$\mathbf{P}_{\mathbf{A}} = \mathbf{A} [\mathbf{A}^H \mathbf{A}]^{-1} \mathbf{A}^H, \quad (20)$$

is the orthogonal projection matrix onto the subspace spanned by the columns of \mathbf{A} . Intuitively, the solution corresponds to the spatial matched filter solution with additional null-steering constraints. However, this method cannot take transmitter I/Q imbalance into account and is therefore suffering from the problems discussed in Section II.B. This gives us the motivation to develop a WL beamforming method, which is not only mitigating the unwanted I/Q imbalance effects but also steering nulls towards the forbidden PU directions.

B. Proposed RF-Aware WL Null-Steering Method

I/Q imbalance corrupts the output of the beamformer as shown in (15). In order to eliminate this unwanted behavior without individual I/Q imbalance cancellation in all parallel transmitter branches, the null-steering method has to be modified. Based on (17), the requirements for all PU directions $\theta_{\text{PU},i}$, $i = 1, \dots, M$ should be set as

$$\mathbf{a}^H(\theta_{\text{PU},i}) \mathbf{K}_1 \mathbf{w}_1 + \mathbf{a}^H(\theta_{\text{PU},i}) \mathbf{K}_2 \mathbf{w}_2^* = 0 \quad (21)$$

$$\mathbf{a}^H(\theta_{\text{PU},i}) \mathbf{K}_1 \mathbf{w}_2 + \mathbf{a}^H(\theta_{\text{PU},i}) \mathbf{K}_2 \mathbf{w}_1^* = 0. \quad (22)$$

Now, we can take conjugate transpose of (21) and transpose of (22). Then after reorganizing terms, the requirements can be given by

$$\mathbf{w}_1^H \mathbf{K}_1^H \mathbf{a}(\theta_{\text{PU},i}) + \mathbf{w}_2^T \mathbf{K}_2^H \mathbf{a}(\theta_{\text{PU},i}) = 0 \quad (23)$$

$$\mathbf{w}_1^H \mathbf{K}_2^T \mathbf{a}^*(\theta_{\text{PU},i}) + \mathbf{w}_2^T \mathbf{K}_1^T \mathbf{a}^*(\theta_{\text{PU},i}) = 0 \quad (24)$$

which can be further combined and expressed as

$$\begin{aligned} \tilde{\mathbf{w}}^H \tilde{\mathbf{A}}(\theta_{\text{PU},i}) &= \begin{bmatrix} \mathbf{w}_1 \\ \mathbf{w}_2^* \end{bmatrix}^H \begin{bmatrix} \mathbf{K}_1^H \mathbf{a}(\theta_{\text{PU},i}) & \mathbf{K}_2^T \mathbf{a}^*(\theta_{\text{PU},i}) \\ \mathbf{K}_2^H \mathbf{a}(\theta_{\text{PU},i}) & \mathbf{K}_1^T \mathbf{a}^*(\theta_{\text{PU},i}) \end{bmatrix} \\ &= \mathbf{0}_{1 \times 2} \end{aligned} \quad (25)$$

where $\tilde{\mathbf{w}} \in \mathbb{C}^{2N \times 1}$ and $\tilde{\mathbf{A}}(\theta_{\text{PU},i}) \in \mathbb{C}^{2N \times 2}$. In addition to the null-steering, we also want to eliminate the self interference of the signal, i.e the conjugated signal term in (15). This can be interpreted as an additional null constraint given by

$$\tilde{\mathbf{w}}^H \tilde{\mathbf{a}}_{\text{SI}}(\theta_d) = \tilde{\mathbf{w}}^H \begin{bmatrix} \mathbf{K}_2^T \mathbf{a}^*(\theta_d) \\ \mathbf{K}_1^T \mathbf{a}^*(\theta_d) \end{bmatrix} = 0 \quad (26)$$

where $\tilde{\mathbf{a}}_{\text{SI}}(\theta_d) \in \mathbb{C}^{2N \times 1}$. Now the final null-steering matrix $\tilde{\mathbf{A}} \in \mathbb{C}^{2N \times 2M+1}$, including the PU null-steering constraints as well as the self-interference elimination, can be given by

$$\tilde{\mathbf{A}} = [\tilde{\mathbf{A}}(\theta_{\text{PU},1}), \tilde{\mathbf{A}}(\theta_{\text{PU},2}), \dots, \tilde{\mathbf{A}}(\theta_{\text{PU},M}), \tilde{\mathbf{a}}_{\text{SI}}(\theta_d)]. \quad (27)$$

Then, based on the previous sub-section, the proposed RF-aware WL null-steering method can be seen as maximizing the first term in (17) under the null-steering constraints in $\tilde{\mathbf{A}}$, or equivalently expressed as

$$\max_{\tilde{\mathbf{w}}} \left| \tilde{\mathbf{w}}^H \tilde{\mathbf{a}}(\theta_d) \right|^2 \quad \text{subject to} \quad \begin{cases} \tilde{\mathbf{w}}^H \tilde{\mathbf{A}} = \mathbf{0} \\ \tilde{\mathbf{w}}^H \tilde{\mathbf{w}} \leq \sqrt{\alpha} \end{cases} \quad (28)$$

where $\tilde{\mathbf{a}}(\theta_d) = [(\mathbf{K}_1^H \mathbf{a}(\theta_d))^T, (\mathbf{K}_2^H \mathbf{a}(\theta_d))^T]^T \in \mathbb{C}^{2N \times 1}$. Note that this is an augmented version of the conventional null-steering method. The optimum solution for this optimization task is given by

$$\tilde{\mathbf{w}}_{\text{NS}} = \frac{\sqrt{\alpha}}{\|(\mathbf{I} - \mathbf{P}_{\tilde{\mathbf{A}}}) \tilde{\mathbf{a}}(\theta_d)\|} (\mathbf{I} - \mathbf{P}_{\tilde{\mathbf{A}}}) \tilde{\mathbf{a}}(\theta_d). \quad (29)$$

Here, $\mathbf{P}_{\tilde{\mathbf{A}}} \in \mathbb{C}^{2M+1 \times 2M+1}$ is the orthogonal projection matrix (based on the augmented null-steering matrix) and is given by

$$\mathbf{P}_{\tilde{\mathbf{A}}} = \tilde{\mathbf{A}} [\tilde{\mathbf{A}}^H \tilde{\mathbf{A}}]^{-1} \tilde{\mathbf{A}}^H. \quad (30)$$

Finally, for any given weights $\tilde{\mathbf{w}}$, the transmit power of the array is $(\|\mathbf{K}_1 \mathbf{w}_1 + \mathbf{K}_2 \mathbf{w}_2^*\|^2 + \|\mathbf{K}_1 \mathbf{w}_2 + \mathbf{K}_2 \mathbf{w}_1^*\|^2) \sigma_s^2$. Thus

for any $\tilde{\alpha}$ used in (29), appropriate weight scaling can always be easily determined to set the desired total transmit power.

Note that the solution obtained by (29) automatically deploys the RF imperfection knowledge properly to suppress unwanted degradation of the radiation pattern. As a consequence, the actual I/Q imbalance cancellation in the parallel transmitter branches is not needed at all. In practice, the information of RF imperfections can be obtained, e.g. with the help of feedback loops which are anyways present in the transmitter hardware due to e.g. gain control.

Finally, the WL null-steering weight matrix $\mathbf{W}_{\text{NS}}(\theta_d) \in \mathbb{C}^{N \times 2}$, to be used for signal precoding under I/Q imbalance, is given by

$$\mathbf{W}_{\text{NS}}(\theta_d) = [\tilde{\mathbf{w}}_{\text{NS}}(1 : N), \tilde{\mathbf{w}}_{\text{NS}}^*(N + 1 : 2N)]. \quad (31)$$

The results of this method compared with the conventional null-steering method with and without I/Q imbalance are next illustrated using computer simulations.

IV. SIMULATIONS AND NUMERICAL EXAMPLES

Numerical examples and performance results are based on MATLAB simulations where an ULA with 8 antenna elements is used. The element spacing d is equal to half of the RF signal wavelength λ . The desired direction is selected to be $\theta_d = 130^\circ$, while the forbidden PU directions are equal to $\theta_{\text{PU},1} = 50^\circ$ and $\theta_{\text{PU},2} = 95^\circ$. Since the information of the PU directions is based on e.g. DOA estimation which is not necessarily exact, two additional null constraints are set around ($\pm 2^\circ$) the actual PU directions. The total transmit power is set to be equal to 1 for both beamforming methods.

I/Q imbalance in the RF chains is implemented in two different ways; as a random unequal I/Q imbalance in the transmitter branches (g and ϕ are uniformly distributed in the range of 0.85–1.15 and -15 – 15° , respectively), and as a systematic I/Q imbalance where the I/Q imbalance coefficients are equal in all transmitter branches (g is 0.85 and ϕ is 15°). In the former case, all parallel transmitter branches have their own hardware which is the most probable solution in distributed array structures. In the latter case, transmitter branches are sharing hardware resources, such as RF LO. In reality, the behavior is most likely somewhere in-between, that is I/Q imbalance has common and independent subcomponents (from one transmitter branch to another). However, these two scenarios represent the two limiting cases.

Fig. 3 shows the radiation pattern of the conventional null-steering method in case of random I/Q imbalance. The response to the desired direction is well maintained but the nulls towards the PUs are even 58 dB weaker than without I/Q imbalance. This means that the beamformer is effectively transmitting energy to the forbidden PU directions and thus causing severe interference to the primary communication system. This can be prevented by using the proposed WL null-steering method whose results are depicted in Fig. 4. The results show that the desired radiation characteristics are now well maintained, not only to the desired direction, but also to the forbidden PU directions.

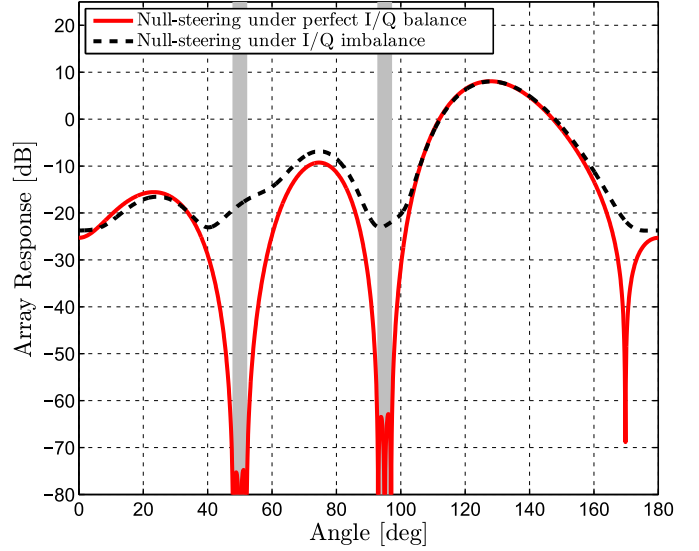

Fig. 3. Radiation patterns of the conventional null-steering method under random I/Q imbalance, 8 antenna elements. $\theta_d = 130^\circ$, $\theta_{\text{PU},1} = 50^\circ \pm 2^\circ$ and $\theta_{\text{PU},2} = 95^\circ \pm 2^\circ$.

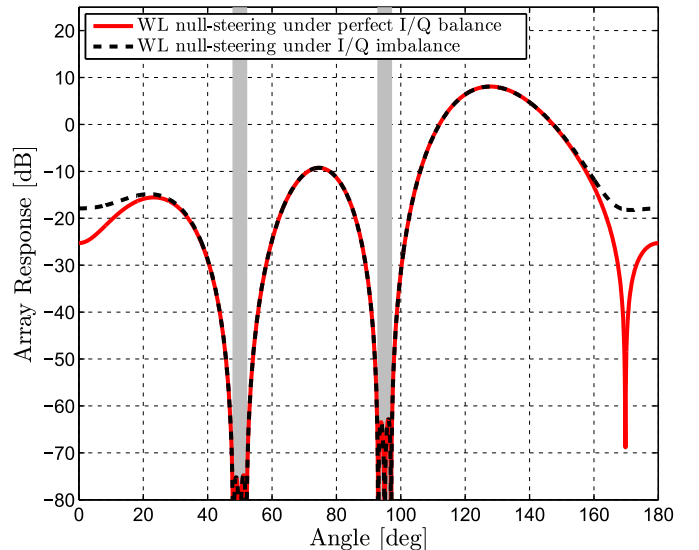

Fig. 4. Radiation patterns of the proposed WL null-steering method under random I/Q imbalance, 8 antenna elements. $\theta_d = 130^\circ$, $\theta_{\text{PU},1} = 50^\circ \pm 2^\circ$ and $\theta_{\text{PU},2} = 95^\circ \pm 2^\circ$.

The radiation pattern of the conventional null-steering method under systematic I/Q imbalance is illustrated in Fig. 5. Again, the classical beamformer is transmitting more energy to both PU directions than without I/Q imbalance. The most severe problem is the mirror direction $180^\circ - \theta_d$ where a strong mirror peak can be seen. This is actually due to the existence of the conjugated precoding weights in (11). In addition, the beamformer loses 0.8 dB of its gain to the desired direction due to the scaling of the first term in (11) with \mathbf{K}_1 . The results of the proposed WL null-steering method are depicted in Fig. 6. They show, again, that the proposed method is able to maintain the wanted radiation characteristics to the desired direction while steering strong nulls towards the PUs.

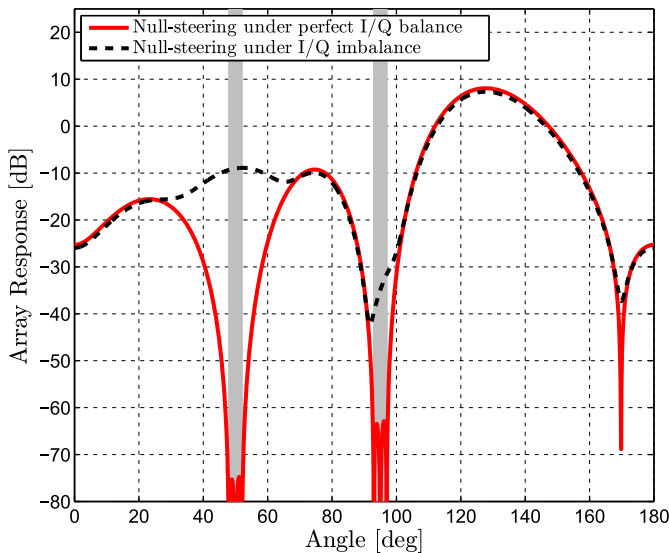

Fig. 5. Radiation patterns of the conventional null-steering method under systematic I/Q imbalance, 8 antenna elements. $\theta_d = 130^\circ$, $\theta_{PU,1} = 50^\circ \pm 2^\circ$ and $\theta_{PU,2} = 95^\circ \pm 2^\circ$.

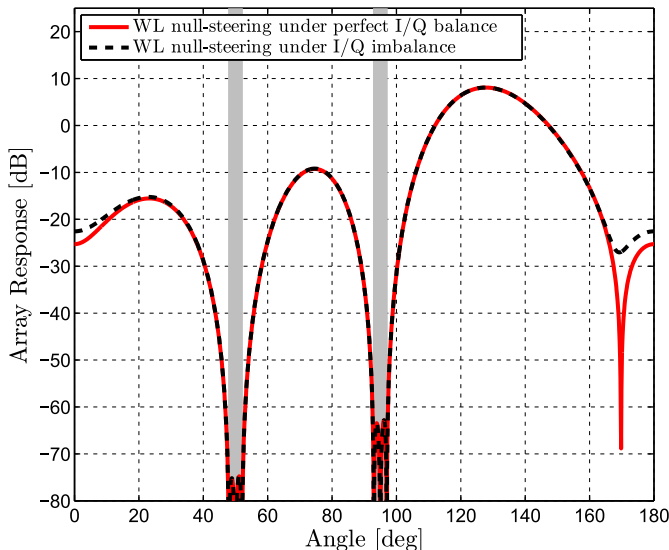

Fig. 6. Radiation patterns of the proposed WL null-steering method under systematic I/Q imbalance, 8 antenna elements. $\theta_d = 130^\circ$, $\theta_{PU,1} = 50^\circ \pm 2^\circ$ and $\theta_{PU,2} = 95^\circ \pm 2^\circ$.

V. CONCLUSION

Transmitter digital beamforming and null-steering characteristics are heavily affected by the imperfections in the associated RF circuits. In this paper, effects of one common RF imperfection, namely I/Q imbalance, were studied. Firstly, closed-form analysis of the available beamforming and null-steering capabilities under RF I/Q imbalance was carried out. Secondly, the RF-aware WL beamforming method was proposed and formulated for suppressing the unwanted behavior due to RF I/Q imbalance without individual I/Q imbalance cancellation in all parallel transmitter branches. Simulation results under random as well as systematic I/Q imbalance showed that the proposed WL beamforming method succes-

fully mitigates the unwanted I/Q imbalance effects and thus restores the wanted radiation properties, despite of imperfect RF circuits, whereas the conventional null-steering method loses its capabilities to steer strong nulls towards forbidden directions. This offers an efficient null-steering solution for SU transmitters in cognitive radio systems such that efficient interference protection towards PUs can be maintained even if operating with low cost RF chains that are commonly subject to substantial RF imperfections.

REFERENCES

- [1] M. Islam et al, "Spectrum survey in Singapore: Occupancy measurements and analyses," in *Proc. CROWNCOM 2008*, May 2008, pp. 1–7.
- [2] V. Valenta et al., "Towards cognitive radio networks: Spectrum utilization measurements in suburb environment," in *Proc. IEEE RWS 2009*, Jan. 2009, pp. 352–355.
- [3] M. Lopez-Benitez, A. Umbert, and F. Casadevall, "Evaluation of spectrum occupancy in Spain for cognitive radio applications," in *Proc. 69th IEEE VTC 2009*, Apr. 2009, pp. 1–5.
- [4] T. Taher et al., "Dynamic spectrum access opportunities for public safety in land mobile radio bands," in *Proc. CROWNCOM 2011*, Jun. 2011, pp. 355–359.
- [5] K. Patil et al., "Spectrum occupancy statistics in the context of cognitive radio," in *Proc. 14th International Symposium on Wireless Personal Multimedia Communications*, Oct. 2011, pp. 1–5.
- [6] S. Haykin, "Cognitive radio: brain-empowered wireless communications," *IEEE J. Sel. Areas Commun.*, vol. 23, no. 2, pp. 201–220, Feb. 2005.
- [7] R. Martin and R. Thomas, "Algorithms and bounds for estimating location, directionality, and environmental parameters of primary spectrum users," *IEEE Trans. Wireless Commun.*, vol. 8, no. 11, pp. 5692–5701, Nov. 2009.
- [8] F. Penna and D. Cabric, "Bounds and tradeoffs for cooperative DoA-Only localization of primary users," in *Proc. IEEE GLOBECOM 2011*, Dec. 2011, pp. 1–5.
- [9] L. De Nardis, M. Di Benedetto, A. Akhtar, and O. Holland, "Combination of DOA and beamforming in position-based routing for underlay cognitive wireless networks," in *Proc. CROWNCOM 2012*, Jun. 2012, pp. 218–223.
- [10] K. Zarifi, S. Affes, and A. Ghreyeb, "Collaborative null-steering beamforming for uniformly distributed wireless sensor networks," *IEEE Trans. Signal Process.*, vol. 58, no. 3, pp. 1889–1903, Mar. 2010.
- [11] D. Piazza, D. Michele, and K. Dandekar, "Two port reconfigurable CRLH leaky wave antenna with improved impedance matching and beam tuning," in *Proc. 3rd European Conference on Antennas and Propagation, 2009*, Mar. 2009, pp. 2046–2049.
- [12] S. Mirabbasi and K. Martin, "Classical and modern receiver architectures," *IEEE Commun. Mag.*, vol. 38, no. 11, pp. 132–139, Nov. 2000.
- [13] T. Schenk and J.-P. Linnartz, *RF Imperfections in High-Rate Wireless Systems: Impact and Digital Compensation*. Springer, 2008.
- [14] K. Karakayali et al., "Optimum zero-forcing beamforming with per-antenna power constraints," in *Proc. IEEE ISIT 2007*, Jun., pp. 101–105.
- [15] B. Razavi, "RF transmitter architectures and circuits," in *Proc. IEEE Custom Integrated Circuits, 1999*, 1999, pp. 197–204.
- [16] L. Anttila, M. Valkama, and M. Renfors, "Frequency-selective I/Q mismatch calibration of wideband direct-conversion transmitters," *IEEE Trans. Circuits Syst. II, Exp. Briefs*, vol. 55, no. 4, pp. 359–363, Apr. 2008.
- [17] D. Darsena et al., "Widely-linear beamforming/combining techniques for MIMO wireless systems," in *Proc. ISCCSP 2012*, May, pp. 1–5.
- [18] M. Y. Frankel and R. D. Esman, "Dynamic null steering in an ultrawideband time-steered array antenna," *Applied Optics*, vol. 37, no. 23, pp. 5488–5494, Aug. 1998.
- [19] B. Friedlander and B. Porat, "Performance analysis of a null-steering algorithm based on direction-of-arrival estimation," *IEEE Trans. Acoust., Speech, Signal Process.*, vol. 37, no. 4, pp. 461–466, Apr. 1989.
- [20] L. Godara, "Application of antenna arrays to mobile communications. II. beam-forming and direction-of-arrival considerations," *Proc. IEEE*, vol. 85, no. 8, pp. 1195–1245, Aug. 1997.